



SECOSelect Correctional Solutions

Heated Holding Cabinets and Serving Lines

Brought to you by

Phone
Email
Website
Address

When we send our foodservice equipment into correctional facilities, we know it's not going to be treasured like grandma's fine china.

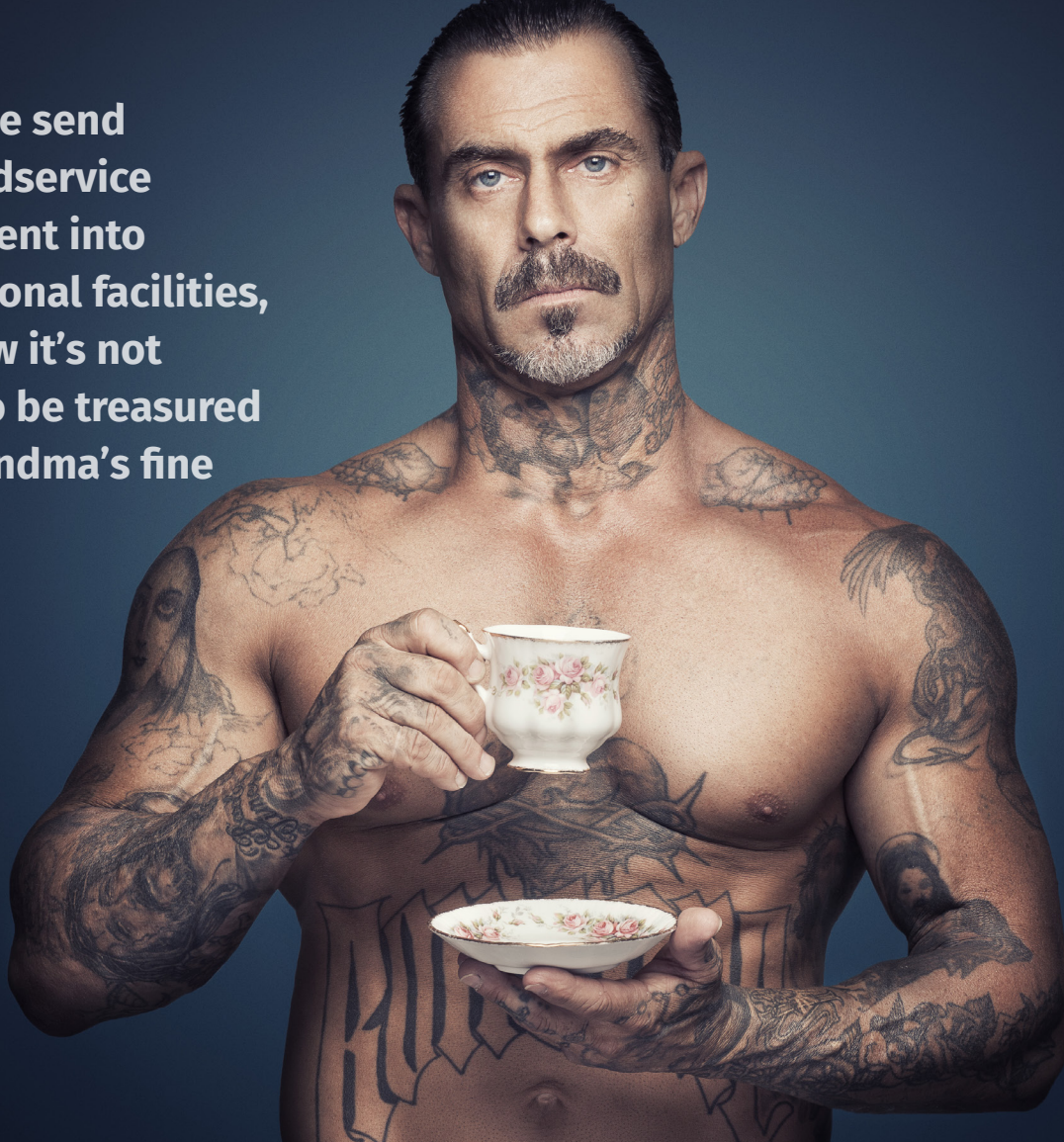

Introduction

When we send our foodservice equipment into correctional facilities, we know it's not going to be treasured like grandma's fine china. To say that it needs to be durable is an extraordinary understatement. It has to be virtually indestructible. It has to withstand the most demanding food service environment, year after year after year, enabling you to safely serve food in county jails all the way to Supermax prisons.

We know that it's not easy to serve inmates three full meals every single day. Since 1927, SECOSelect's® mission has been to craft our Correctional Line of heated holding cabinets and serving lines in a way that will make your job easier and safer. Our foodservice products are engineered to last longer and work better than anything you have used in the past. We stand behind our American Made craftsmanship with the industry leading 5-year standard parts warranty.

We invite you to Test Our Metal®



SECOSelect® Overview



Secure Stainless Steel Control Panel with intrusion-resistant Lexan window

Correctional Hasp Lock - welded and bolted to the frame for maximum security

Full perimeter, steel reinforced, door gaskets to maintain temperature and eliminate heat loss

Tamper-Proof Screws

Customizable: Left-hinged door

Perimeter bumper standard

Customizable: Stainless Steel Legs

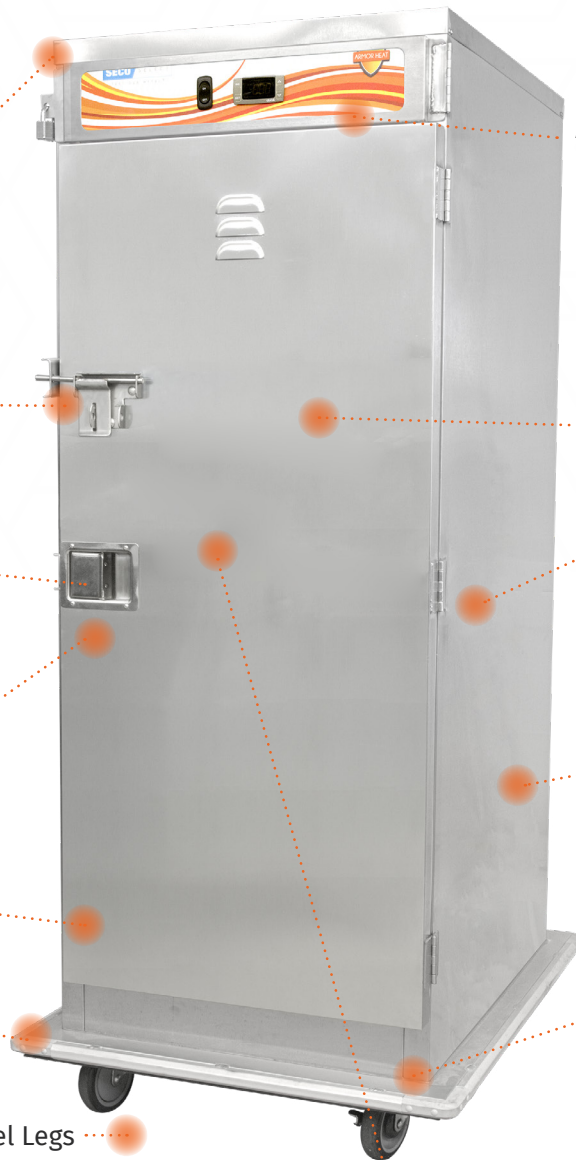

Armor Heat® Industry's most precise and efficient temperature control system with easy-to-read digital thermometer. Adjustable thermostat reaches up to 230° Fahrenheit

Hot, cold, or ambient food storage

Insulated and certified up to 1,000 degrees with a Class A fire rating

All stainless steel welded construction including Welded Stainless Steel Hinges for maximum strength, security, and durability

Reinforced with welded triple point base frame Caster Plates - won't bend or break

Designed to hold Universal Trays & Pans Including:

- Correctional Trays
- Steam Table Pans
- Patient Trays

Correctional Solutions are available with the following features

Secure Stainless Steel Control Panel with intrusion-resistant Lexan window



Supermax-approved locking mechanism



Heavy-Duty Stainless Steel Hinges are welded to the frame



Tamper-Proof Screws

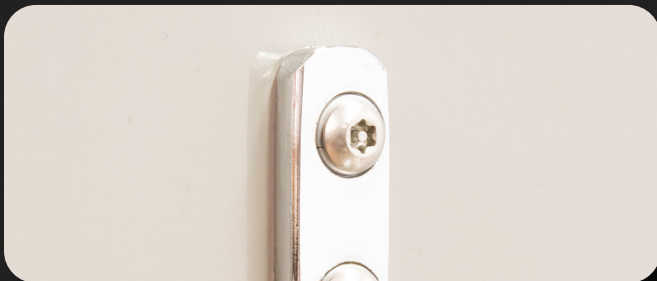

Recessed Push Handles are welded to the frame

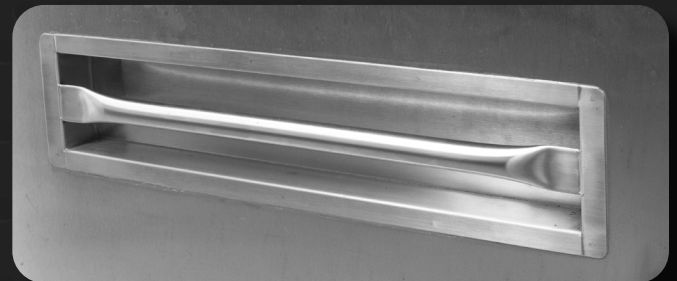

Paddle Latch



Institutional Vertical Handle

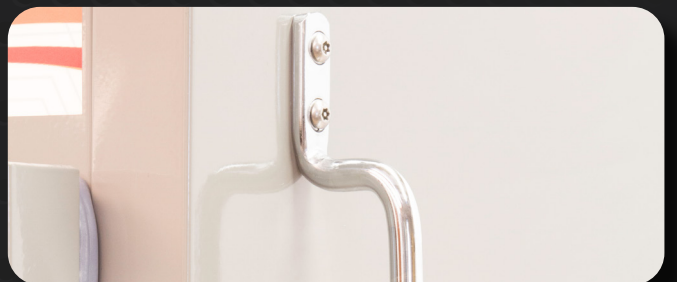



Insulated Tray and Beverage Delivery Cabinet

Serve your inmates faster with our Insulated Tray and Beverage Delivery Cabinet. Crafted from heavy-duty stainless steel, our delivery cabinet system is easy to maneuver and has a large capacity for insulated, covered trays. With its reinforced, triple point base frame welded Caster Plates, our Insulated Tray and Beverage Delivery Cabinet can withstand years of being pushed and pulled throughout the halls of your facility.

Customizations Available

- Available to hold any size tray
- Right-hinged doors
- Left-hinged doors
- Keep hot food piping hot with Armour Heat® the industry's most precise and efficient temperature control system with easy-to-read digital thermometer and adjustable thermostat that reaches up to 230° Fahrenheit

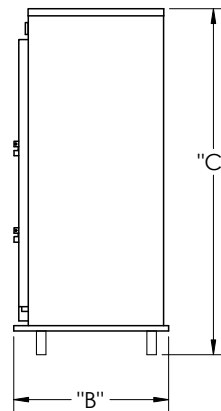
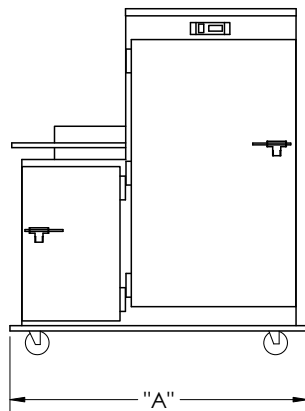

Model #	Trays	Pan Size	Width Dim A	Depth Dim B	Height Dim C	Voltage	Watts	Amperage	Ship Weight
CMP-CC-J-80	60-80	15" x 13-1/2" x 2-3/4"	61 3/4"	35 1/2"	54"	-	-	-	540
CMP-CCJ-80 HEATED/ICE Cooled	60-80	15" x 13 1/2" 18" x 26"	62 3/4"	32 5/8"	73 1/2"	120	990	8.25	750



Heated Cabinets

Storing food at the right temperature and moving it to and from their destination in harsh food service environments is just what SECOSelect heated cabinets were designed for. Built with solid steel frames, triple point base frame welded caster plates, and a host of other innovations allow them to thrive in the most challenging environments.

- Keep hot food piping hot with Armor Heat® the industry's most precise and efficient temperature control system with easy-to-read digital thermometer and adjustable thermostat that reaches up to 230° Fahrenheit
- Insulated and certified up to 1,000 degrees with a Class A fire rating
- Designed to hold every size tray imaginable including:
 - o Correctional Trays
 - o Steam Table Pans
 - o Sheet Pans



Customizations Available

- Pass-through doors
- Dutch doors
- Left-hinged doors
- Stainless steel legs

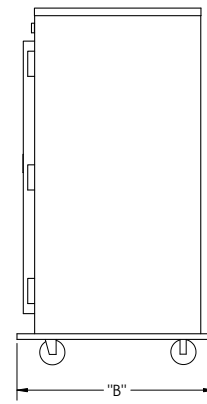
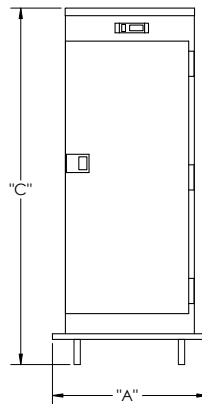

Model #	Capacity 18" x 26" Trays 2 1/2" Pans	Width Dim A	Depth Dim B	Height Dim C	Watts	AMPS	Ship Weight
M11UA4UC	4 sets UA brackets Under Counter	25 1/2"	34 1/2"	34"	750	6.25	300
M11UA6	6 sets UA brackets	25 1/2"	34 1/2"	45 13/16"	750	6.25	400
M11UA9	9 sets UA brackets	25 1/2"	35 1/2"	53"	990	8.25	430
M11UA12	12 sets UA brackets	25 1/2"	35 1/2"	71 3/16"	990	8.25	550
M11UA16	16 sets UA brackets	25 1/2"	35 1/2"	71 3/16"	990	8.25	558
ROAD WARRIOR	11 sets UA brackets	25 1/2"	35 1/2"	60 1/16"	990	8.25	530



Insulated Holding Cabinets

Our team built safety, security, and durability into every inch of our Insulated Holding Cabinets. The cabinet system is engineered for heavy use and has stainless steel channel pan slides for 12" x 20" pans.

- Armor Heat® Industry's most precise and efficient temperature control system with easy-to-read digital thermometer. Adjustable thermostat reaches up to 230° Fahrenheit.
- All stainless steel welded construction including Welded Stainless Steel Hinges for maximum strength, security, and durability.
- Secure Stainless Steel Control Panel with intrusion resistant Lexan window.
- Designed to hold Steam Table Pans.



Customizations Available

- Pass-through doors
- Dutch doors
- Left-hinged doors
- Right-hinged doors
- Cord Reel
- Stainless Steel Legs

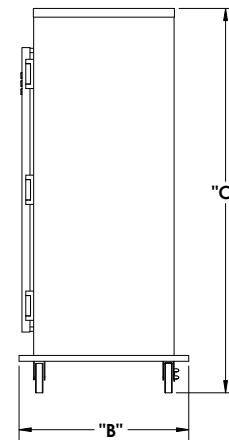
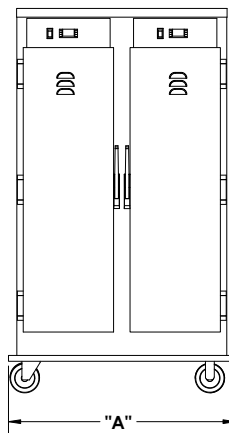

Model #	Capacity/ Angles	Pan Size	Width Dim A	Depth Dim B	Height Dim C	Voltage	Watts	Amperage	Ship Weight
CMP-C5	5	12" x 20" x 2 1/2"	20 13/16"	30"	35 1/2"	120	500	4.16	185
CMP-C9	9	12" x 20" x 2 1/2"	20 13/16"	30"	45 7/16"	120	500	6.25	295
CMP-C12	12	12" x 20" x 2 1/2"	20 13/16"	30"	38"	120	750	6.25	300
CMP-C12UP	12	12" x 20" x 2 1/2"	20 13/16"	30"	54 3/16"	120	990	8.25	325
CMP-C16	16	12" x 20" x 2 1/2"	20 13/16"	30"	65 1/2"	120	990	8.25	375



Heated Bulk Food Cart



Our serving lines provide the quality and reliability that is synonymous with all SECOSelect® products, and our customization options allow us to be flexible to the specific needs of your serving environment.

- 208 or 240 volt Armor Heat® system for heated wells with electronic temperature controls with digital displays.
- 6 1/2" deep heated wells for 12" x 20" pans for tray make-up or meal servings.
- Lower heated compartments have Armor Heat® System and electronic temperature controls with digital displays. Each hold (5) 12" x 20" x 2 1/2" pans with stainless steel channels, welded in place.
- Full perimeter door gaskets to efficiently maintain temperature and eliminate heat loss.



Customizations Available

- Pass-through doors
- Stainless Steel Legs
- Tray Slides
- Left-hinged doors
- Gravity Steel legs
- Available without lower compartments

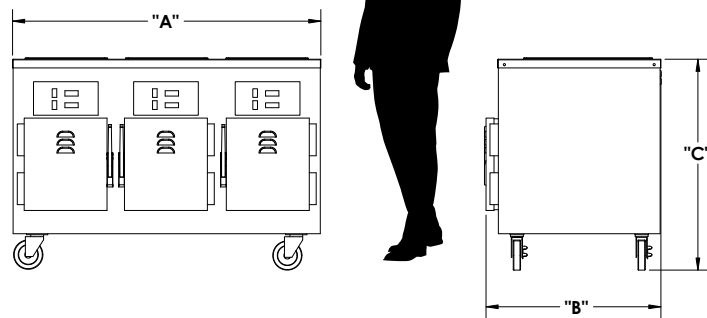

Model #	Capacity/ Angles	Pan Size	Width Dim A	Depth Dim B	Height Dim C	Voltage	Watts	Amperage	Ship Weight
CW-3-COR	15	12" X 20" X 2 1/2"	56"	33"	36 3/4"	208 or 240	3000	13.6	655
CW-4-COR	20	12" X 20" X 2 1/2"	72 1/4"	33"	36 1/2"	208 or 240	4000	18.1	700
CW-5-COR	25	12" X 20" X 2 1/2"	89 1/8"	33"	36 1/2"	208 or 240	5000	21.7	800

About SECOSelect® an Affinis® Company

Long respected for outstanding products, performance, and engineering, SECOSelect® builds rugged, high quality equipment designed to handle the rigors of correctional institutions, restaurants, commercial kitchens, schools, hospitals, and organizations of all kinds. We focus on every single detail, from heavy-duty construction and energy efficient insulation to top of the line electronics and heating technology, and we use only the highest grade of materials to manufacture our equipment because we want our products to enjoy a long lifetime of regular use.

Our energy efficient heated holding cabinets and serving lines have some of the lowest operating costs in the food service industry. They use less energy, they are made with stronger materials, and they will last longer. We work closely with design consultants, food service representatives, institutional customers, and kitchen managers to make sure our equipment functions perfectly in any food service environment, at any time, in any situation.

Test Our Metal®

SECOSelect® is an Affinis® Company

About Affinis

Buy Affinis. Buy American.™

Affinis is proud to present a premium assortment of commercial food service products including SaniServ (soft serve/smoothie machines) and SECOSelect (premium serving counters and holding cabinets). Our product families are made entirely in the USA. Included in the group are companies that provide the highest quality products in each of their respective niches.

Today's marketplace offers a wide array of food service suppliers. Our families of products will provide you with American made quality from companies with proven track records of dependability and service at an economical price.

www.Affinis.biz