

**arc**  
cardinal

*creator of experiences.*



2024/2025 PORTFOLIO

## CORPORATE BRANDS



ARCOROC

## PARTNER BRANDS





arc  
cardinal

*creator of experiences.*

## TRUSTED & TRUE

As part of Arc International, founded in 1825, we will always stay true to our roots of quality, durability, and value. We will always be your first and most trusted source for tableware and buffetware.

### VISIT OUR SHOWROOMS:

TOTOWA, NJ    NEW YORK, NY    MIAMI, FL

[ARCCARDINAL.COM](https://arccardinal.com)





# *Creators of Experience*

**CREATE. CURATE. CELEBRATE.**

Elevating your guest's experience is your priority. Bringing your vision to life is ours. No matter the experience, we are here to help you create a remarkable one. Our expertly crafted collections of tableware, buffetware, and accessories supports the needs of today's chefs, mixologists and sommeliers.

This visionary approach is the founding principle of our culture and brands.



## *South & Pine*

MORRISTOWN, NJ

Utilizing a variety of different collections, South & Pine has created an upscale, farm to table experience for their customers.

"I am really enjoying the Dudson plateware that we have incorporated onto our tables this year. They have a wide range of styles, and the plates we chose are stunning. I love the subtle line work on the Evo, and the very organic coloration on the Finca. They add a lot of creativity to our dishes, without overpowering the food."

**LEIA GACCIONE // OWNER & CHEF**

SHOP THESE COLLECTIONS:

Harvest Collection - Page 166

Evo Collection - Page 178

The Maker's Collection: Finca - Page 156



## *317 Main Street*

FARMINGDALE, NY

"I love the plateware and products from Arc Cardinal. The diversity, quality and variety is what we love at my restaurants 317 Main Street and Vico. Whether it's a simple plate with light texture and color to a plate that adds to our customers experience, we as a restaurant and I as a chef love using it all on a daily basis."

**ERIC LEVINE // OWNER & CHEF**



SHOP THESE COLLECTIONS:

The Maker's Collection: Jute Grey - Page 158

Candour Azure Collection - Page 200



## *Luna's Mexican Kitchen*

CAMPBELL, CALIFORNIA

"Here at LUNA Mexican Kitchen, we love to surprise our guests with the smallest of details. Stemware is part of the guest experience; it's the unexpected things that make an experience stellar. Currently, we are serving Riff Pinot Grigio and Poseidon Pinot Noir, which both use sustainable and organic farming practices. We are excited to be bringing in an orange wine for spring. Also, Rosé is no longer just a seasonal wine, it is consumed year-round because it is fresh, usually low in alcohol, and pairs well with our Golden Beet Citrus Salad or Shrimp Ceviche."

**JO LERMA LOPEZ // FOUNDER & CHEF**



SHOP THESE COLLECTIONS:  
Broadway Collection - Page 88  
Sequence Collection - Page 38  
Evo Collection - Page 178



## *Valued Partner*



We are proud to support and partner with The USA & Canada delegation of the Association of Maîtres Cuisiniers de France (MCF). MCF accepts only the best French Chefs in the world. Being a Maître Cuisinier (or Master Chef of France) is a prestigious honor that is held in high regard. These chefs are given the highest classification in restaurant guides and are regularly mentioned in top food and travel publications. MCF's motto is, "To preserve and spread the French culinary arts, encourage training in cuisine, and assist in professional development."

We are very pleased to be partnering with such an illustrious organization!





Abert Flatware (Page 274)



Rock Dew (Page 83)



Maria Portugal Terracota Collection (Page 236)

# Preview of New Products



Grace Collection (Pg. 16)

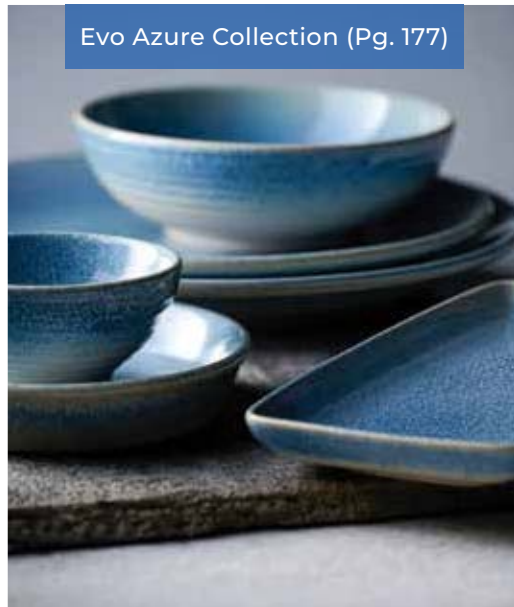

Evo Azure Collection (Pg. 177)



Tempo Lamps (Page 354)



Stack Up Cross Collection (Page 86)



Exaltation Collection (Page 34)



Dudson Harvest Mediterranean Moresque (Page 179)

! MORE NEW PRODUCTS INSIDE!

# Table of Contents



## Drinkware

### CHEF & SOMMELIER®

#### AERIS **NEW**

Grace	16
Zephyr	18

#### KRYSTA

Cabernet	22
Distinction <b>NEW</b>	28
Evidence <b>NEW</b>	30
Exalt	32
Exaltation <b>NEW</b>	34
Open Up	36
Reveal Up	38
Sequence	40
Sublym	44
Symétrie <b>NEW</b>	46
Villeneuve	48
Aska	50
Lima	50
Macaron	51
Primary	52

### CRISTAL D'ARQUES®

#### KRYSTA

Architecte	54
Macassar	54
Rendez-Vous	55

### ARCOROC®

#### ARMORIM + SHEER RIM

Malea Brio	58
Mineral	59
Romeo	60
V. Juliette	62
Precision	64

### FULLY TEMPERED GLASS

Amelia	68
Artic	69
Excalibur	70
Arcadie	74
Essentials	76
Gotham	78
Granite	79
Mugs	80
Norvege	80
Prysm	81
Rock Line <b>NEW</b>	82
Rock Dew <b>NEW</b>	83
Stack Up	84
Stack Up Cross <b>NEW</b>	86

### ARMORIM

Urbane	90
--------	----

### EVERYDAY CLASSICS

Broadway	94
Imperator, Elysees, Quadrilles <b>NEW</b>	96
Luxe <b>NEW</b>	97
Monti <b>NEW</b>	98
Aristocrat	100
Brixton <b>NEW</b>	101
Cabernet	102
Cooler	103
Islande	104
Mason Jar	105
Perfection	105
Salto	106
Shetland	108
Wine Bottom Tumblers	109
ArcoPrime	110

### OCCASION

Sparkling Wine	114
Spirits	120
Beer	134
In-Room Tumblers	143
Decanters & Carafes	144
Mix	150
Outdoor Perfect	158



## Dinnerware

### DUDSON

#### VITRIFIED CERAMIC

The Maker's Collection: FINCA	164
The Maker's Collection: JUTE GREY <b>NEW</b>	166
The Maker's Collection: PORTO BLUE <b>NEW</b>	168
The Maker's Collection: URBAN	170
EVO Origins	172
Harvest	174
Harvest Mediterranean Moresque <b>NEW</b>	178
Harvest Norse	180
Harvest Norse White <b>NEW</b>	182
Organic White	184

#### VITRIFIED STONEWARE

EVO Azure <b>NEW</b>	186
EVO	188

#### WOOD

Acacia Wood	191
-------------	-----

### CHEF & SOMMELIER®

#### STONEWARE

Geode	194
-------	-----

#### VITRIFIED CERAMIC

Eternity Plus	196
---------------	-----

#### BONE CHINA

Infinity	200
Infinity Coupes	202

### ARCOROC®

#### ALUMINITE®

Athena <b>NEW</b>	206
Candour	208
Candour Azure	210
Candour Cirrus	212
Candour Coupes	214
Horizon	216
Rondo	218
Universal <b>NEW</b>	220
Vintage	222

#### EXTRA STRONG PORCELAIN

Appetizer	226
Daring	226
Square Up	227

### MARIA PORTUGAL TERRACOTA **NEW**

#### STONEWARE

Terra	230
-------	-----

### SANTA ANITA®

#### STONEWARE

Reflections <b>NEW</b>	234
Reflections Blue Band <b>NEW</b>	236
Accessories	238

ARCOROC®	
OPAL®	
Brush	242
Evolutions	244
Intensity White	246
Restaurant White	248
Smart Cuisine	250

FULLY TEMPERED GLASS

Arcade	254
Fleur	254
ROC	254
Stack Bowls	255

NON-TEMPERED GLASS

Dessert	255
---------	-----

Satineo	286
Stone	287
Stone Satin	288
Vesca	289

STEAK KNIVES

Chef & Sommelier®	292
Abert <b>NEW</b>	294
Arcoroc®	295

SERVING ACCESORIES

18/10	
Lazzo	297
Living Mirror	298
18/0	
Vesca	299



## Flatware

CHEF & SOMMELIER®

18/10	
Black Oak	259
Black Oak Satin <b>NEW</b>	259
Burlington	260
Diaz	260
Ezzo	261
Fluted	261
Harper	262
Harper Satin <b>NEW</b>	262
Knox	263
Kya	263
Kya Sand	264
Lazzo	264
Liv II <b>NEW</b>	265
Orzon	265
Orzon Patina	266
Renzo	266
Renzo Patina	267

SOLA

18/10	
Alessandria	269
Baguette Black	270
Baguette Copper	270
Baguette Vintage Stone Wash	271
Imperial Chopsticks	271
Living Mirror	272
Living Satin	272
Luxus Sand	273
Miracle	273

ABERT **NEW**

18/10	
Elegant	275
Enrico VII	275
Matisse	276
Matisse Vintage	276
Milord	277
Neo	277
Rada	278
Rinascimento	278
Splendido	278
Stilo	279
Victory	279

ARCOROC®

18/0	
Amber	281
Blake <b>NEW</b>	281
Capitale	282
Greenwich	282
Harrison	283
Latham	283
Latham Sand	284
Liv	284
Liv Gunmetal <b>NEW</b>	285
Matiz	285
Mikayla	286



## Buffetware

ABERT

Domino	304
Mix & Play	310
Cosmo	311
Accessories	314
Serving <b>NEW</b>	315

ALFI

Albergo	318
Gusto Top Therm	320
Hotello	322
Lightweight Carafe	324

THERMOS

Brew In Carafe	328
Carafe With Gauge	330
Carafe With Lever	332
Twist and Pour	334
Accessories	336

CHASSEUR

Round & Oval Casserole	340
Round & Oval Casserole	342
Terrine Rectangle Gratin	344
Round & Oval Dish	346
Trivets <b>NEW</b>	347

## Accessories

ABERT **NEW**

Tempo Lamps	352
Tempo Mini Lamps	354
Saturno Lamps	355
Art & Table	356
Serving	357
Wine & Bar	358

ARCOROC

Ashtrays & Votive	359
-------------------	-----

## Reference

Custom Decoration	360
Care & Handling	362
Index	371



The background of the image is a photograph of a desert landscape. In the foreground, there is a smooth, undulating sand dune that slopes upwards from the bottom left towards the right. The sand is a light, warm beige color. Above the dune, the sky is a clear, pale blue, occupying the upper two-thirds of the frame. The overall composition is simple and minimalist, with a focus on natural textures and colors.

# *Drinkware*



Chef & Sommelier® is a prestigious brand that reflects our French gastronomic heritage. Aimed at the finest restaurants and bars, Chef & Sommelier® helps professionals express their creativity and talent.

Shown FP303 Specialty Cocktail (7.5 Oz.)



# Aeris

— HANDMADE —

Aeris – Mouth-blown crystalline glassware. Each piece embodies a lightweight design that seamlessly combines refinement and luxurious craftsmanship. Add a touch of sophistication to every moment.

Grace <i>NEW</i>	16
Zephyr <i>NEW</i>	18



Mouth Blown – Creating ultra thin walls, these pieces are mouth blown.



# *Grace*

NEW

The Grace collection blends modern aesthetics with timeless elegance, enhancing the dining ambiance with its sophisticated design and mouth-blown craftsmanship.





**FP633**  
Flute (8 Oz.)  
H: 9 1/2" T: 1 13/16"  
M: 2 5/16" B: 2 3/4"  
2 Dz.



**FP678**  
Universal Wine (14 Oz.)  
H: 8 3/4" T: 2 1/2"  
M: 3 1/8" B: 3"  
2 Dz.



**FP631**  
Universal Wine (18 Oz.)  
H: 9" T: 2 1/2"  
B: 3 1/8" M: 3 1/2"  
2 Dz.



**FP632**  
Universal Wine (23 1/2 Oz.)  
H: 9 1/4" T: 2 7/8"  
M: 3 7/8" B: 3 3/8"  
2 Dz.



# *Zephyr* NEW

Infusing timeless artistry with contemporary elegance, the Zephyr collection is designed to enthrall and charm. Each piece is delicately crafted with both precision and exquisite artistry.





**FP303**  
Specialty Cocktail (7 ½ Oz.)  
H: 6 ½" T: 4 ½"  
B: 3 ⅞" M: 4 ¾"  
2 Dz.



**FP373**  
Rocks (10 ½ Oz.)  
H: 2 7⁄8" T: 3 ¼"  
B: 3 ¼" M: 3 ¼"  
2 Dz.



**FP374**  
Double Rocks (13 Oz.)  
H: 3 ⅝" T: 3 ⅝"  
B: 3 ⅞" M: 3 ⅞"  
2 Dz.



**FP375**  
Hi Ball (12 Oz.)  
H: 5" T: 2 ½"  
B: 2 ½" M: 2 ½"  
2 Dz.







Krysta® – High-performance crystal glass. A new generation of lead-free crystal exceeding 2,000 industrial dishwashing cycles. Superior strength, complete transparency, long-lasting brilliance and perfect acoustics.

Cabernet	22
Distinction <i>NEW</i>	28
Evidence <i>NEW</i>	30
Exalt	32
Exaltation <i>NEW</i>	34
Open Up	36
Reveal Up	38
Sequence	40
Sublym	44
Symétrie <i>NEW</i>	46
Villeneuve	48
Aska	50
Lima	50
Macaron	51
Primary	52
<b>Cristal D'Arques</b>	
Architecte	54
Macassar	54
Rendez-Vous	55



Sheer Rim – Fine rims add for a refined customer experience.



Effervescence Plus – A technology that develops even, delicate bubbliness, delighting the eyes and taste buds alike.





# Cabernet

A wide range of sizes with superior strength;  
it's a perfect blend of elegance and endurance.



**FJ036**  
Bordeaux (16 Oz.)  
H: 8 ½" T: 2 ¾"  
B: 3 ½" M: 3 ¾"  
1 Dz.



**FJ035**  
Bordeaux (21 ¼ Oz.)  
H: 9 ½" T: 2 ¾"  
B: 3 ½" M: 3 ¾"  
1 Dz.



**FJ037**  
Burgundy (24 Oz.)  
H: 8 ¾" T: 2 ¾"  
B: 3 ½" M: 4 ¾"  
1 Dz.



**46978**  
Tall Wine (8 ½ Oz.)  
H: 7 ½" T: 2 ¼"  
B: 2 ¾" M: 2 ⅞"  
2 Dz.



**50816**  
Tall Wine (10 ½ Oz.)  
H: 7 ¾" T: 2 ¾"  
B: 3" M: 3 ⅙"  
2 Dz.



**46973**  
Tall Wine (12 Oz.)  
H: 8" T: 2 ½"  
B: 3" M: 3 ⅙"  
2 Dz.



**46961**  
Tall Wine (16 Oz.)  
H: 8 ¾" T: 2 ¾"  
B: 3" M: 3 ½"  
2 Dz.



# Cabernet *cont'd.*



## **L0571**

Tall Wine with pour line (16 Oz.)

H: 8  $\frac{5}{8}$ " T: 2  $\frac{3}{4}$ " B: 3" M: 3  $\frac{1}{2}$ "

2 Dz.

APPROXIMATE POUR LINES

6 oz. Bottom of Grapes | 9 oz. Top of Grapes



## **46888**

Tall Wine (19  $\frac{3}{4}$  Oz.)

H: 9  $\frac{1}{16}$ " T: 2  $\frac{13}{16}$ "

B: 3  $\frac{1}{4}$ " M: 3  $\frac{1}{16}$ "

2 Dz.



## **D0795**

Tall Wine (25  $\frac{1}{4}$  Oz.)

H: 10" T: 3"

B: 3  $\frac{1}{8}$ " M: 3  $\frac{15}{16}$ "

1 Dz.





**47019**  
Ballon Wine (12 Oz.)  
H: 7 <sup>3</sup>/<sub>16</sub>" T: 2 <sup>7</sup>/<sub>16</sub>"  
B: 3" M: 3 <sup>5</sup>/<sub>8</sub>"  
2 Dz.



**47017**  
Ballon Wine (16 Oz.)  
H: 7 <sup>3</sup>/<sub>4</sub>" T: 3"  
B: 3" M: 3 <sup>15</sup>/<sub>16</sub>"  
2 Dz.



**47026**  
Ballon Wine (20 Oz.)  
H: 8 <sup>1</sup>/<sub>4</sub>" T: 3 <sup>3</sup>/<sub>16</sub>"  
B: 3 <sup>1</sup>/<sub>4</sub>" M: 4 <sup>3</sup>/<sub>16</sub>"  
2 Dz.



**46981**  
Ballon Wine (24 Oz.)  
H: 8 <sup>1</sup>/<sub>16</sub>" T: 3 <sup>3</sup>/<sub>8</sub>"  
B: 3 <sup>1</sup>/<sub>4</sub>" M: 4 <sup>1</sup>/<sub>2</sub>"  
2 Dz.



**E2788**  
Young Wine (12 Oz.)  
H: 7 <sup>7</sup>/<sub>16</sub>" T: 2 <sup>1</sup>/<sub>4</sub>"  
B: 3 <sup>3</sup>/<sub>16</sub>" M: 3 <sup>1</sup>/<sub>2</sub>"  
2 Dz.  
3 <sup>1</sup>/<sub>2</sub> Oz. pour line



**E2790**  
Young Wine (16 Oz.)  
H: 8 <sup>1</sup>/<sub>2</sub>" T: 2 <sup>5</sup>/<sub>16</sub>"  
B: 3 <sup>1</sup>/<sub>4</sub>" M: 3 <sup>13</sup>/<sub>16</sub>"  
2 Dz.  
4 Oz. pour line

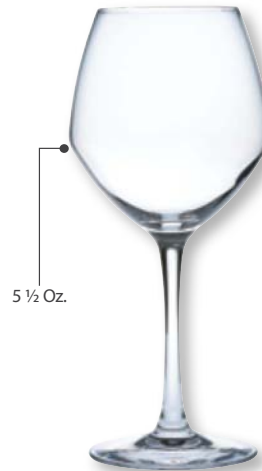

**E2789**  
Young Wine (19 1/2 Oz.)  
H: 8 <sup>1</sup>/<sub>2</sub>" T: 2 <sup>3</sup>/<sub>4</sub>"  
B: 3 <sup>3</sup>/<sub>16</sub>" M: 4 <sup>1</sup>/<sub>8</sub>"  
2 Dz.  
5 <sup>1</sup>/<sub>2</sub> Oz. pour line



**P0112**  
Millesime Wine (15 3/4 Oz.)  
H: 8 <sup>3</sup>/<sub>16</sub>" T: 2 <sup>3</sup>/<sub>4</sub>"  
B: 3 <sup>1</sup>/<sub>4</sub>" M: 3 <sup>5</sup>/<sub>8</sub>"  
2 Dz.

# Cabernet *cont'd.*



**V5794**  
Cordial (2 ¼ Oz.)  
H: 5 ¼" T: 1 ⅝"  
B: 2" M: 1 ⅞"  
2 Dz.



**14798**  
Port (4 Oz.)  
H: 5 ⅞" T: 1 ⅝"  
B: 2" M: 2 ⅛"  
2 Dz.



**48024\***  
Flute (6 Oz.)  
H: 8 ⅞" T: 2"  
B: 2 ¾" M: 2 ¼"  
2 Dz.



**D0796\***  
Flute (8 Oz.)  
H: 9 ¼" T: 2"  
B: 2 ¾" M: 2 ⅞"  
2 Dz.



**G3573**  
All Purpose (13 ½ Oz.)  
H: 6 ⅞" T: 2 ⅞"  
B: 3 ⅞" M: 3 ⅞"  
2 Dz.



**G3570**  
Iced Tea (16 Oz.)  
H: 7 ⅞" T: 2 ⅞"  
B: 3 ⅞" M: 3 ⅞"  
2 Dz.



**P3882**  
Cocktail (7 ½ Oz.)  
H: 6 ¾" T: 4 ½"  
B: 3" M: 4 ½"  
1 Dz.



**N6831**  
Cocktail (10 Oz.)  
H: 7 ½" T: 4 ¾"  
B: 3" M: 4 ¾"  
1 Dz.



**N6815**  
Champagne Coupe (10 Oz.)  
H: 6 ¾" T: 4 ⅝"  
B: 2 ⅞" M: 4 ⅝"  
1 Dz.



Shown Double Old Fashioned (12 ½ Oz.) | Rocks (10 ½ Oz.) | Beverage (15 Oz.)



**L2369**  
Beverage (15 Oz.)  
H: 6 ½" T: 2 ¾"  
B: 2 ¼" M: 2 ¾"  
2 Dz.



**G3674**  
Beverage (11 ½ Oz.)  
H: 4 ¾" T: 2 ½"  
B: 2 ½" M: 2 ½"  
2 Dz.



**G3658**  
Hi Ball (7 ¾ Oz.)  
H: 4 ¾" T: 2 ¼"  
B: 1 ⅞" M: 2 ¾"  
2 Dz.



**L2370**  
Double Old Fashioned (12 ½ Oz.)  
H: 3 ½" T: 3 ¾"  
B: 2 ⅞" M: 3 ½"  
2 Dz.



**G3666**  
Rocks (10 ½ Oz.)  
H: 3 ¼" T: 3 ⅞"  
B: 2 ⅝" M: 3 ⅝"  
2 Dz.



**G3659**  
Rocks (7 Oz.)  
H: 2 ¾" T: 2 ¾"  
B: 2 ⅜" M: 2 ¾"  
2 Dz.

# *Distinction* <sup>NEW</sup>

The long, seamless stem gives way to a beautifully angled bowl. The natural curvature in the bowl provides proper pour control eliminating waste and increasing profits.





**Q9080\***  
 Flute (7 ¾ Oz.)  
 H: 9 ½" T: 1 ¾"  
 B: 2 ¾" M: 2 ⅝"  
 2 Dz.



**Q9062**  
 Wine (13 Oz.)  
 H: 8 ⅝" T: 2 ¼"  
 B: 3 ¼" M: 3 ⅞"  
 2 Dz.



**Q9064**  
 Wine (16 Oz.)  
 H: 9 ⅝" T: 2 ½"  
 B: 3 ⅜" M: 3 ¾"  
 2 Dz.



SHEER RIM  
 1 mm

\* EFFERVESCENCE PLUS

# *Evidence* <sup>NEW</sup>

The versatile design of Evidence can effortlessly interchange between wine, cocktail, mocktails or even specialty brews! The low profile design makes it a great choice for banquets.





**V2821**  
 Wine (15 ½ Oz.)  
 H: 8 ¼" T: 2 ½"  
 B: 3" M: 3 ⅝"  
 2 Dz.



**V2620**  
 Wine (12 Oz.)  
 H: 7 ½" T: 2 ⅝"  
 B: 2 ⅞" M: 2 ¾"  
 2 Dz.



**V2822**  
 Wine (9 Oz.)  
 H: 7" T: 2 ⅜"  
 B: 2 ¾" M: 2 ⅞"  
 2 Dz.



**V2823\***  
 Flute (5 ½ Oz.)  
 H: 7 ½" T: 1 ¾"  
 B: 2 ⅞" M: 2 ⅜"  
 2 Dz.



SHEER RIM  
 1.1 mm

\* EFFERVESCENCE PLUS

# *Exalt*

The alliance between perfect curves and incredible resistance coupled with the harmony of continuous and elegant lines.







**E7698**  
Wine (6 ¾ Oz.)  
H: 7 ¼" T: 2 ¼"  
B: 2 ¾" M: 2 ¾"  
2 Dz.



**E7697**  
Wine (8 ¼ Oz.)  
H: 7 ½" T: 2 ¾"  
B: 2 ¾" M: 3"  
2 Dz.



**E7696**  
Wine (10 ½ Oz.)  
H: 7 7/8" T: 2 ½"  
B: 3" M: 3 ¼"  
2 Dz.



**E7695**  
Wine (13 ¾ Oz.)  
H: 8 ½" T: 2 ¾"  
B: 3 ½" M: 3 ½"  
2 Dz.



**E7700\***  
Flute (6 ¼ Oz.)  
H: 8 ¼" T: 2"  
B: 2 ¾" M: 2 ¾"  
2 Dz.



**SHEER RIM**  
1.2 mm

\* EFFERVESCENCE PLUS

# *Exaltation*

NEW

Embrace the Parisian notion of subtle sophistication with the Exaltation wine glasses. The sleek, pulled stem design exudes modern simplicity, while the wide bowl allows the wine's color and aroma to take center stage.





**Q1151\***  
Specialty Flute (10 ¼ Oz.)  
H: 8 ¾" T: 2 ¾"  
B: 2 7/8" M: 3 1/6"  
2 Dz.



**V6191**  
Wine (13 Oz.)  
H: 8 ½" T: 3 ¾"  
B: 3 1/8" M: 3 3/8"  
1 Dz.



**V6190**  
Wine (16 Oz.)  
H: 9" T: 2 ½"  
B: 3 3/8" M: 3 ½"  
1 Dz.



**V6189**  
Wine (19 Oz.)  
H: 9 ½" T: 2 ½"  
B: 3 3/8" M: 3 ¾"  
1 Dz.



**V6719**  
Wine (25 ½ Oz.)  
H: 10 ¼" T: 2 7/8"  
B: 3 ½" M: 4 3/16"  
1 Dz.



SHEER RIM  
1.2 mm

\* EFFERVESCENCE PLUS



## *Open Up*

Contemporary and revolutionary design suitable for tasting all types of young wines with its large oxygenation area and closed rim to facilitate the concentration of flavors.



**U1051\***  
Flute (6  $\frac{3}{4}$  Oz.)  
H: 9" T: 2  $\frac{3}{8}$ "  
B: 2  $\frac{1}{16}$ " M: 2  $\frac{3}{4}$ "  
2 Dz.  
4 Oz. pour line



**SHEER RIM**  
0.9 mm



**U1010**  
 Round (12 1/2 Oz.)  
 H: 8 1/4" T: 2 1/16"  
 B: 3" M: 3 3/4"  
 2 Dz.  
 3 1/4 Oz. pour line



**U1011**  
 Universal Tasting (13 1/2 Oz.)  
 H: 9" T: 2 3/8"  
 B: 3" M: 3 1/2"  
 2 Dz.  
 2 Oz. pour line



**U1012**  
 Soft (15 3/4 Oz.)  
 H: 8 7/8" T: 2 7/16"  
 B: 3 1/4" M: 4"  
 2 Dz.  
 3 Oz. pour line



**U1013**  
 Tannic (18 1/2 Oz.)  
 H: 9 1/8" T: 2 3/4"  
 B: 3 1/4" M: 4 1/8"  
 2 Dz.  
 3 1/2 Oz. pour line



**U1032**  
 Open Up Warm Tumbler (10 Oz.)  
 H: 3 3/8" T: 2 3/8"  
 B: 1 7/8" M: 3 7/8"  
 2 Dz.



**U1033**  
 Open Up Old Fashioned (13 1/2 Oz.)  
 H: 3 3/4" T: 2 3/4"  
 B: 1 7/8" M: 3 5/8"  
 2 Dz.



## *3 Steps of Wine Tasting*

LOOK

OXYGENATION SURFACE  
> Aromas Source

SMELL

AROMATIC CHAMBER  
> Aromas Development  
RIM CLOSING OF THE BOWL  
> Aromas Concentration

TASTE

SHEER RIM (0.9MM)  
> Pleasant Touch on Lips  
CHIMNEY  
> Lower Alcohol Perception

1 Collection, 1 Natural Gauge 2-4 Oz., 2 Modern Shapes to enhance your wine service.

## SOFT

Large oxygenation surface and smaller opening of the bowl for perfect tasting of young or mature, red and white soft wines.

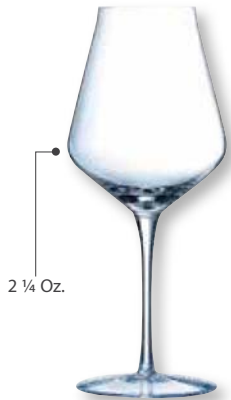

**J8908\***  
Soft Wine (11 Oz.)  
H: 8 1/2" T: 2"  
B: 3" M: 3 1/4"  
2 Dz.



**J8743\***  
Soft Wine (13 1/2 Oz.)  
H: 9 1/8" T: 2 1/4"  
B: 3 1/4" M: 3 1/2"  
2 Dz.



**N1738**  
Soft Wine (17 1/2 Oz.)  
H: 9 5/8" T: 2 3/8"  
B: 3 3/8" M: 3 3/4"  
1 Dz.



**J8907\***  
Soft Flute (8 Oz.)  
H: 9 1/4" T: 1 3/4"  
B: 2 3/4" M: 2 5/8"  
2 Dz.

## INTENSE

Extra-large oxygenation surface for perfect tasting of red, young or mature, strong and tannic wines.



**J8742**  
Intense Wine (16 Oz.)  
H: 8 3/8" T: 2 3/8"  
B: 3 3/8" M: 4"  
2 Dz.



**J9014**  
Intense Wine (19 1/2 Oz.)  
H: 9" T: 2 5/8"  
B: 3 3/8" M: 4 1/4"  
2 Dz.



SHEER RIM  
0.9 mm

\* EFFERVESCENCE PLUS



# Sequence

The Glassware Sequence Of The Future. The perfect design progression, bringing a modern update to a classical shape with the essence of crafted crystal.



**N9696**  
Port (7 Oz.)  
H: 7 ½" T: 1 ¾"  
B: 2 ⅝" M: 2 ½"  
2 Dz.

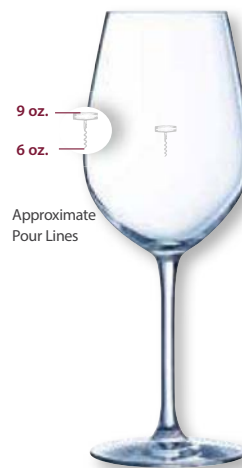

**Q1069**  
Corkscrew Universal (16 Oz.)  
H: 9" T: 2 ⅜"  
B: 3 ¼" M: 3 ⅝"  
1 Dz.





**L5635**  
 Universal (13 Oz.)  
 H: 8 ¼" T: 2 ¼"  
 B: 3" M: 3 ⅛"  
 1 Dz.



**L5633**  
 Universal (16 Oz.)  
 H: 9" T: 2 ⅞"  
 B: 3 ¼" M: 3 ⅞"  
 1 Dz.



**L5638**  
 Universal (19 ½ Oz.)  
 H: 9 ¼" T: 2 ⅝"  
 B: 3 ½" M: 3 ⅝"  
 1 Dz.



**L5636**  
 Burgundy (20 ½ Oz.)  
 H: 8" T: 2 ⅝"  
 B: 3 ⅜" M: 3 ⅞"  
 1 Dz.



**N9710**  
 Bordeaux (21 Oz.)  
 H: 9 ¼" T: 2 ¾"  
 B: 3 ½" M: 3 ¾"  
 2 Dz.



**L5637**  
 Bordeaux (26 Oz.)  
 H: 9 ⅜" T: 2 ⅝"  
 B: 3 ⅜" M: 3 ½"  
 1 Dz.



SHEER RIM  
 1 mm

\* EFFERVESCENCE PLUS

Shown Cooler (16 Oz.), Double Old Fashioned (13 ½ Oz.), Coupe Cocktail (7 ¾ Oz.)



**L5640\***  
Flute (6 Oz.)  
H: 8 ¼" T: 1 7/8"  
B: 2 ¾" M: 2 ¼"  
1 Dz.



**Q3702**  
Nick and Nora Cocktail (5 ¼ Oz.)  
H: 5 5/8" T: 2 ¾"  
B: 2 3/8" M: 2 ¾"  
2 Dz.



**L5641**  
Coupe Cocktail (7 ¾ Oz.)  
H: 5 7/8" T: 4 3/8"  
B: 3" M: 4 3/8"  
1 Dz.



**Q7785\***  
Coupe Cocktail (7 Oz.)  
H: 6" T: 3 1/16"  
B: 2 ¾" M: 3 1/16"  
2 Dz.



**L5642**  
All Purpose (14 Oz.)  
H: 6 <sup>9</sup>/<sub>16</sub>" T: 2 <sup>1</sup>/<sub>2</sub>"  
B: 3" M: 3 <sup>1</sup>/<sub>8</sub>"  
1 Dz.



**N9711**  
Iced Tea (16 Oz.)  
H: 7 <sup>1</sup>/<sub>4</sub>" T: 2 <sup>3</sup>/<sub>4</sub>"  
B: 3" M: 3 <sup>3</sup>/<sub>8</sub>"  
2 Dz.



**P0089**  
Belgian Beer (12 <sup>1</sup>/<sub>2</sub> Oz.)  
H: 5 <sup>7</sup>/<sub>8</sub>" T: 2 <sup>1</sup>/<sub>2</sub>"  
B: 2 <sup>7</sup>/<sub>8</sub>" M: 3 <sup>1</sup>/<sub>4</sub>"  
2 Dz.



**L5757**  
Rocks (8 <sup>1</sup>/<sub>2</sub> Oz.)  
H: 3 <sup>1</sup>/<sub>4</sub>" T: 2 <sup>3</sup>/<sub>4</sub>"  
B: 2 <sup>1</sup>/<sub>8</sub>" M: 3 <sup>1</sup>/<sub>8</sub>"  
1 Dz.



**L5758**  
Rocks (10 <sup>1</sup>/<sub>2</sub> Oz.)  
H: 3 <sup>5</sup>/<sub>16</sub>" T: 3"  
B: 2 <sup>1</sup>/<sub>4</sub>" M: 3 <sup>3</sup>/<sub>8</sub>"  
1 Dz.



**L5756**  
Double Old Fashioned (13 <sup>1</sup>/<sub>2</sub> Oz.)  
H: 3 <sup>5</sup>/<sub>8</sub>" T: 3"  
B: 2 <sup>3</sup>/<sub>8</sub>" M: 3 <sup>3</sup>/<sub>8</sub>"  
1 Dz.



**L5754**  
Hi Ball (11 <sup>1</sup>/<sub>2</sub> Oz.)  
H: 5 <sup>3</sup>/<sub>4</sub>" T: 2 <sup>1</sup>/<sub>8</sub>"  
B: 2" M: 2 <sup>5</sup>/<sub>8</sub>"  
1 Dz.



**L5755**  
Cooler (16 Oz.)  
H: 6 <sup>3</sup>/<sub>8</sub>" T: 2 <sup>1</sup>/<sub>2</sub>"  
B: 2 <sup>1</sup>/<sub>2</sub>" M: 3"  
1 Dz.

# *Sublym*

Elegant & Timeless Design. The Sublym collection brings classic sophistication with a high and narrow bowl design. Designed with no seam, an extra flat foot and an elegant stem. Beautifully complementing Chef & Sommelier® Lima collection tumblers.





**L2609**  
Wine (8 ¾ Oz.)  
H: 8 ½" T: 2"  
B: 2 ¾" M: 2 ¾"  
2 Dz.



**L2761**  
Wine (13 Oz.)  
H: 9 ¼" T: 2 ¼"  
B: 3" M: 3 ½"  
2 Dz.



**N1739**  
Wine (16 ½ Oz.)  
H: 9 7/8" T: 2 3/8"  
B: 3" M: 3 3/8"  
1 Dz.



**V3604**  
Wine (20 ¼ Oz.)  
H: 10 ¼" T: 2 ½"  
B: 3 ¼" M: 3 5/8"  
1 Dz.  
OLD SKU: N1744



**L2762\***  
Flute (7 ½ Oz.)  
H: 9 ½" T: 1 ¾"  
B: 2 ¾" M: 2 ¼"  
2 Dz.



**L3678**  
Coupe Cocktail (8 Oz.)  
H: 7 ½" T: 4 ½"  
B: 3" M: 4 ½"  
2 Dz.



**N4742**  
Ballon (21 ¼ Oz.)  
H: 9 ½" T: 2 ¾"  
B: 3 ¼" M: 4 ½"  
1 Dz.



**N5368**  
All Purpose (13 Oz.)  
H: 7 ¼" T: 2 ¼"  
B: 3" M: 3 ½"  
2 Dz.



SHEER RIM  
1 mm

\* EFFERVESCENCE PLUS



*Symétrie* <sup>NEW</sup>

The soft vertical lines of Symétrie create a stunning back drop for the beverage being served.

An extensive collection offering options in wine, cocktail and sparkling wine/Champagne.

Shown Coupe (8 Oz.)



**V1483**  
Wine (13 Oz.)  
H: 9 ¼" T: 2 ¼"  
B: 3" M: 3 ⅛"  
2 Dz.



**V0391**  
Wine (16 ½ Oz.)  
H: 9 ⅞" T: 2 ⅜"  
B: 3" M: 3 ⅜"  
2 Dz.



**V2696**  
Wine (20 ¼ Oz.)  
H: 10 ¼" T: 2 ½"  
B: 3 ¼" M: 3 ⅝"  
1 Dz.



**V1171**  
Coupe (8 Oz.)  
H: 7 ⅞" T: 4 ½"  
B: 3" M: 4 ½"  
2 Dz.



**V2697\***  
Flute (7 ½ Oz.)  
H: 9 ½" T: 2 ½"  
B: 2 ¾" M: 2 ¼"  
2 Dz.



# *Villeneuve by Daniel Boulud*

Meticulously crafted by Daniel Boulud, each glass allows for the true appreciation of the wine, capturing the story of each varietal that is being tasted. This collection seamlessly transitions from fine dining to bistro.







**FN159**  
Sweet Wine (9 Oz.)  
H: 7 <sup>1</sup>/<sub>16</sub>" T: 3"  
B: 3 <sup>3</sup>/<sub>8</sub>" M: 3 <sup>5</sup>/<sub>16</sub>"  
1 Dz.



**FN166**  
Universal Wine (16 Oz.)  
H: 8 <sup>1</sup>/<sub>16</sub>" T: 2 <sup>7</sup>/<sub>16</sub>"  
B: 3 <sup>1</sup>/<sub>4</sub>" M: 3 <sup>1</sup>/<sub>2</sub>"  
1 Dz.



**FN161**  
Universal Wine (18 Oz.)  
H: 9 <sup>3</sup>/<sub>4</sub>" T: 2 <sup>1</sup>/<sub>2</sub>"  
B: 3 <sup>1</sup>/<sub>2</sub>" M: 3 <sup>1</sup>/<sub>2</sub>"  
1 Dz.



**FN160**  
Burgundy (21 <sup>1</sup>/<sub>2</sub> Oz.)  
H: 8 <sup>1</sup>/<sub>16</sub>" T: 2 <sup>1</sup>/<sub>16</sub>"  
B: 3 <sup>1</sup>/<sub>2</sub>" M: 4 <sup>1</sup>/<sub>8</sub>"  
1 Dz.



**FN162**  
Bordeaux (24 <sup>1</sup>/<sub>2</sub> Oz.)  
H: 10 <sup>1</sup>/<sub>8</sub>" T: 2 <sup>7</sup>/<sub>8</sub>"  
B: 3 <sup>1</sup>/<sub>2</sub>" M: 4"  
1 Dz.



**Q1151\***  
Exaltation Specialty Flute (10 <sup>1</sup>/<sub>4</sub> Oz.)  
H: 8 <sup>5</sup>/<sub>16</sub>" T: 2 <sup>5</sup>/<sub>16</sub>"  
B: 2 <sup>7</sup>/<sub>8</sub>" M: 3 <sup>1</sup>/<sub>16</sub>"  
2 Dz.



\* EFFERVESCENCE PLUS

# Aska

Unique & sophisticated shape to create a contemporary and modern experience.



**FP357**  
Tumbler (12 ¾ Oz.)  
H: 4 7/8" T: 2 3/8" B: 3" M: 3"  
4 Dz.



# Lima

Modern angular shapes with sheer rims perfectly complement the Cabernet and Sublym collections.

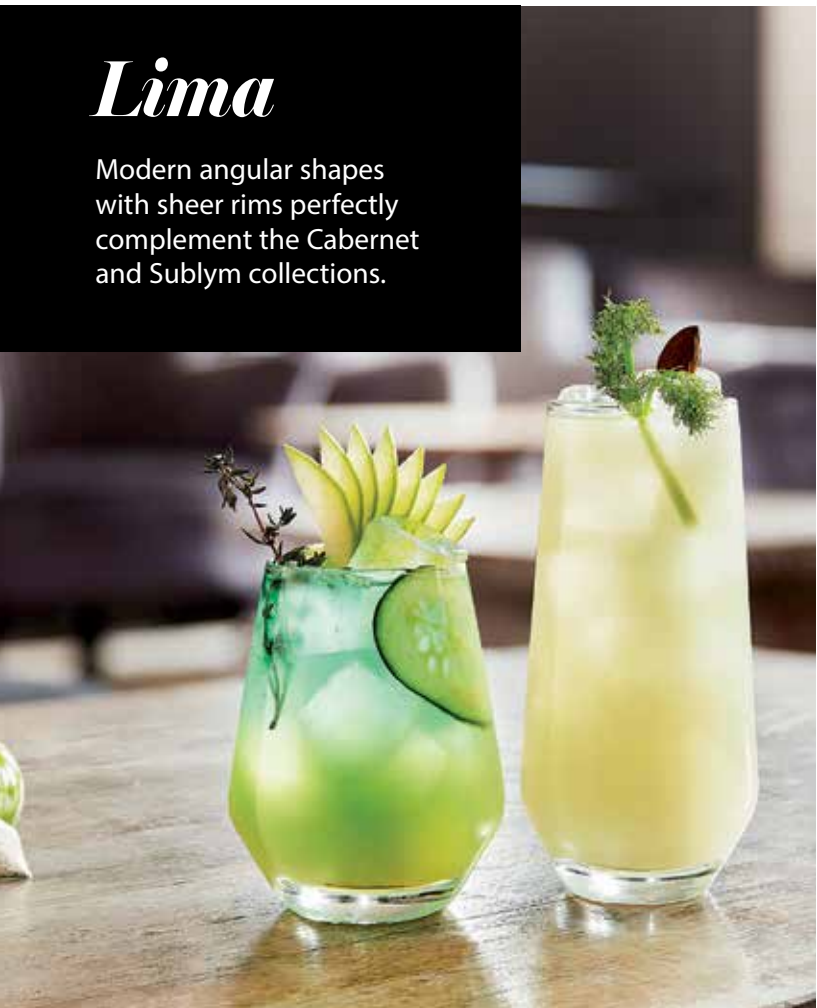

**G3367**  
Old Fashioned (11 ¾ Oz.)  
H: 3 ¼" T: 2 7/8"  
B: 2 1/8" M: 3 1/2"  
2 Dz.



**G3368**  
Hi Ball (12 ¾ Oz.)  
H: 4 ¼" T: 2 1/2"  
B: 1 7/8" M: 3 ¼"  
2 Dz.



**L8110**  
Beverage (13 ½ Oz.)  
H: 5 3/8" T: 2 1/2"  
B: 2" M: 3"  
2 Dz.



**L2356**  
Hi Ball (15 ½ Oz.)  
H: 6 1/2" T: 2 3/8"  
B: 1 7/8" M: 2 5/8"  
2 Dz.

# Macaron

A classic glass with modern curves.  
Perfect for wine, cocktails and even beer.



**N0834**  
Macaron Rocks (13 ½ Oz.)  
H: 4" T: 2 ¾"  
B: 2" M: 3 ½"  
2 Dz.

# *Primary*

Multipurpose glassware for wine, cocktails or beverage service. Complement with Cabernet Stemware.



Shown Beverage (14 ¾ Oz.)



**G0036**  
Rocks (9 Oz.)  
H: 3 1/2" T: 2 1/4"  
B: 1 5/8" M: 2 3/4"  
2 Dz.



**G3322**  
Double Old Fashioned (12 Oz.)  
H: 4" T: 2 5/8"  
B: 1 7/8" M: 3"  
2 Dz.



**L8677**  
Hi Ball (13 1/2 Oz.)  
H: 5 1/8" T: 2 1/4"  
B: 1 7/8" M: 3"  
2 Dz.



**G3323**  
Beverage (14 3/4 Oz.)  
H: 4 1/4" T: 2 5/8"  
B: 1 7/8" M: 3 1/4"  
2 Dz.



## *Architecte*

Geometric art and sculpture in glass form. This paneled glass collection brings a sophisticated touch to your beverage service.



**Q4353**  
Rocks (10  $\frac{3}{4}$  Oz.)  
H: 3  $\frac{7}{8}$ " T: 3  $\frac{1}{2}$ "  
B: 2  $\frac{3}{4}$ " M: 3  $\frac{1}{2}$ "  
1 Dz.

## *Macassar*

Striking panel cuts bring a traditional touch to whiskey and cocktails with exceptional clarity.



**Q4340**  
Hi Ball (12 Oz.)  
H: 5" T: 3  $\frac{1}{4}$ "  
B: 2  $\frac{1}{2}$ " M: 3  $\frac{1}{4}$ "  
1 Dz.





CRISTAL D'ARQUES  
PARIS

## *Rendez-vous*

Contemporary multifaceted panel designs with outstanding brightness for beverage presentations.



**Q4354**  
Rocks (10 ¾ Oz.)  
H: 3 ¾" T: 3 ½"  
B: 3" M: 3 ½"  
1 Dz.



**Q4358**  
Hi Ball (12 Oz.)  
H: 5 ½" T: 3 ¼"  
B: 2 ½" M: 3 ¼"  
1 Dz.



# ARCOROC

Arcoroc's glassware collections support the creativity and desires of customers with innovative designs and durable materials.

Each product is designed for intensive use and can stand up to the daily rigors across bars and restaurants.

In addition to the technical qualities that are essential for professionals, Arcoroc® glassware is trendy, functional and offers the wow factor bartenders look for when presenting their beverages.





Thermal strengthening after-process for rim reinforcement and chip resistance. All sheer rim glassware is reinforced with the ArmoRim process creating a refined experience for customers.

Malea Brio	58
Mineral	59
Romeo	60
V. Juliette	62
Precision	64



Effervescence Plus – A technology that develops even, delicate bubblyness, delighting the eyes and taste buds alike.



## *Malea Brio*

Fine rims, sparkling bodies and flavor enhancing teardrop shapes at a great value.



**H8466\***  
Brio Flute (3 Oz.)  
H: 6 <sup>1</sup>/<sub>16</sub>" T: 1 <sup>7</sup>/<sub>8</sub>"  
B: 2 <sup>1</sup>/<sub>8</sub>" M: 2 <sup>1</sup>/<sub>4</sub>"  
2 Dz.



**J1478\***  
Brio Flute (5 <sup>1</sup>/<sub>4</sub> Oz.)  
H: 7 <sup>7</sup>/<sub>8</sub>" T: 2 <sup>1</sup>/<sub>8</sub>"  
B: 2 <sup>3</sup>/<sub>8</sub>" M: 2 <sup>5</sup>/<sub>8</sub>"  
2 Dz.

## *Mineral*

Tall sides and sheer rims suit nearly any wine.



**H2090\***  
Flute (5 ¼ Oz.)  
H: 8 ¾" T: 1 ¾"  
B: 2 ½" M: 2 ⅛"  
2 Dz.



**H2317**  
Wine (11 ¾ Oz.)  
H: 8 ⅝" T: 2 ⅜"  
B: 3" M: 3 ⅛"  
4 Dz.



**H2318**  
Wine (15 Oz.)  
H: 9 ¼" T: 2 ½"  
B: 3" M: 3 ¼"  
4 Dz.

# Romeo

Romeo is the perfect blend of function and style. Offering an extensive line of shapes to suit your many needs.

Made with ArmoRim technology, the fine sheer rims offer strength and beauty.



## P8793

Flute (5 ¾ Oz.)  
H: 7 ⅞" T: 2"  
B: 2 ⅜" M: 2 ⅛"  
1 Dz.

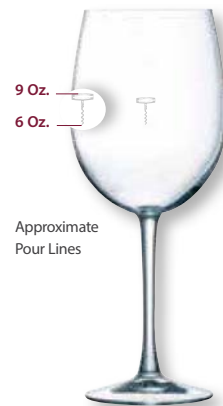

## V2128

Corkscrew Wine (16 Oz.)  
H: 8 ⅜" T: 2 ⅞"  
B: 3" M: 3 ⅜"  
1 Dz.



**P8794**  
Wine (12 Oz.)  
H: 7 7/8" T: 2 1/2"  
B: 3" M: 3 1/8"  
1 Dz.



**V2125**  
Wine (16 Oz.)  
H: 8 3/8" T: 2 7/8"  
B: 3" M: 3 3/8"  
1 Dz.



**P8790**  
Wine (19 Oz.)  
H: 8 7/8" T: 2 7/8"  
B: 3" M: 3 5/8"  
1 Dz.



**V4024**  
All Purpose (13 1/2 Oz.)  
H: 6 9/16" T: 2 7/8"  
B: 3" M: 2 7/8"  
1 Dz.



**P8782**  
All Purpose/ Beer (16 Oz.)  
H: 7" T: 2 7/8"  
B: 3" M: 3 1/4"  
1 Dz.



**V4222**  
Margarita (12 Oz.)  
H: 6 11/16" T: 4 5/8"  
B: 3" M: 4 5/8"  
1 Dz.



**V2761**  
Coupe Cocktail (8 Oz.)  
H: 5 7/8" T: 4 1/8"  
B: 3" M: 4 1/8"  
1 Dz.



**V2760**  
Cocktail (5 1/2 Oz.)  
H: 5 9/16" T: 2 3/4"  
B: 2 3/4" M: 2 3/4"  
1 Dz.



**V4025**  
Martini (5 Oz.)  
H: 6" T: 3 3/4"  
B: 2 3/4" M: 3 3/4"  
1 Dz.



## *V. Juliette*

The angular design of the V. Juliette collection offers a distinctive shape that fits very well with all table styles.



**N5082\***

Flute (7 ¾ Oz.)

H: 8 ½" T: 1 ⅞"

B: 2 ⅞" M: 2 ⅝"

2 Dz.



**N5163**  
Wine (10 Oz.)  
H: 7  $\frac{3}{8}$ " T: 2  $\frac{1}{8}$ "  
B: 2  $\frac{5}{8}$ " M: 3  $\frac{1}{8}$ "  
2 Dz.



**N4907**  
Wine (13  $\frac{1}{2}$  Oz.)  
H: 8  $\frac{1}{8}$ " T: 2  $\frac{1}{4}$ "  
B: 3" M: 3  $\frac{3}{8}$ "  
2 Dz.



**N5993**  
Wine (16  $\frac{3}{4}$  Oz.)  
H: 8  $\frac{1}{2}$ " T: 2  $\frac{1}{2}$ "  
B: 3  $\frac{1}{8}$ " M: 3  $\frac{3}{8}$ "  
2 Dz.



**N5994**  
Hi Ball (13  $\frac{1}{2}$  Oz.)  
H: 4  $\frac{3}{8}$ " T: 2  $\frac{1}{2}$ "  
B: 2" M: 3  $\frac{1}{2}$ "  
2 Dz.



**N5995**  
Double Old Fashioned (11  $\frac{3}{4}$  Oz.)  
H: 3  $\frac{1}{4}$ " T: 3"  
B: 2  $\frac{1}{4}$ " M: 3  $\frac{3}{4}$ "  
2 Dz.



# *Precision*

This tumbler collection features a heavy sham, straight wall and sheer rim.

With a variety of pieces in the collection, Precision offers an elevated look at a valued price point.



Shown Collins/Beverage (13 Oz.), Cooler (16 Oz.)





**P8500**  
Rocks (10 ½ Oz.)  
H: 3 ¼" T: 3 ¼"  
B: 3" M: 3 ¼"  
1 Dz.



**P8495**  
Double Old Fashioned (14 Oz.)  
H: 4" T: 3 ¼"  
B: 3" M: 3 ¼"  
1 Dz.



**P8494**  
Collins/Beverage (13 Oz.)  
H: 5 ¾" T: 2 ¾"  
B: 2 ¾" M: 2 ¾"  
1 Dz.



**P8499**  
Cooler (16 Oz.)  
H: 6 ½" T: 2 ¾"  
B: 2 ½" M: 2 ¾"  
1 Dz.



Shown Excalbur Coupe Cocktail (8 Oz.)



**Fully Tempered** – More resistant to mechanical and thermal shock than regular annealed glass; up to 5X more resistant to breakage.

Amelia	68
Artic	69
Excalibur	70
Arcadie	74
Essentials	76
Gotham	78
Granite	79
Mugs	80
Norvege	80
Prysm	81
Rock Line <b>NEW</b>	82
Rock Dew <b>NEW</b>	83
Stack Up	84
Stack Up Cross <b>NEW</b>	86



Perfectly Stackable - Glassware designed to perfectly stack to optimize storage.



Effervescence Plus – A technology that develops even, delicate bubblyness, delighting the eyes and taste buds alike.

# *Amelia*

The perfectly stackable goblet,  
Amelia is a bars best friend.



**E3562**  
Stacking Goblet (8 ½ Oz.)  
H: 4 ⅝" T: 2 ¾"  
B: 2 ½" M: 3 ⅛"  
4 Dz.



PERFECTLY  
STACKABLE

# Artic

The timeless cut design of Artic evokes feelings of nostalgia while exuding an air of elegance.



**57286**  
Wine (8 Oz.)  
H: 5 3/8" T: 3"  
B: 2 7/8" M: 3"  
4 Dz.



**57070**  
Wine (10 1/2 Oz.)  
H: 5 3/4" T: 3 1/8"  
B: 2 7/8" M: 3 1/8"  
4 Dz.



**53664**  
Juice (6 Oz.)  
H: 3 3/4" T: 2 1/4"  
B: 1 5/8" M: 2 1/4"  
4 Dz.



**75926**  
Hi Ball (8 3/4 Oz.)  
H: 4 3/8" T: 2 3/8"  
B: 2" M: 2 5/8"  
4 Dz.



**D6315**  
Hi Ball (10 1/2 Oz.)  
H: 5" T: 2 3/4"  
B: 2" M: 2 3/4"  
4 Dz.



**57069**  
Beverage (12 1/2 Oz.)  
H: 5 3/8" T: 2 7/8"  
B: 2 1/4" M: 2 7/8"  
4 Dz.

# Excalibur

The workhorse of glassware.

More resistant to mechanical and thermal shock than regular annealed glass—up to 5X more resistant to breakage.



Shown Breeze (15 ¾ Oz.)



### 71084

Tall Wine (8 ½ Oz.)  
H: 6 13/16" T: 2 3/8"  
B: 2 3/4" M: 2 15/16"  
3 Dz.



### 71083

Tall Wine (10 ½ Oz.)  
H: 7 1/4" T: 2 7/8"  
B: 2 3/4" M: 3 3/16"  
3 Dz.



### 71080

Grand Savoie (12 Oz.)  
H: 7 1/2" T: 3"  
B: 3" M: 3 3/8"  
2 Dz.

8 oz.  
6 oz.

Vin

Vin



Approximate  
Pour Lines

### D1CM5312

Vin with pour line (12 Oz.)  
H: 7 1/2" T: 3" B: 3" M: 3 3/8"  
2 Dz.



### 06942

Super Savoie (12 Oz.)  
H: 7 1/8" T: 3"  
B: 3 1/8" M: 3 5/16"  
2 Dz.

**EXCALIBUR  
BREEZE**



**P0776**  
Breeze (11 ¼ Oz.)  
H: 8" T: 2 ¾"  
B: 3" M: 3 ½"  
2 Dz.



**P0777**  
Breeze (15 ¾ Oz.)  
H: 8 ½" T: 2 ¾"  
B: 3" M: 3 ½"  
2 Dz.



**71075**  
Grand Ballon (13 Oz.)  
H: 6 7/8" T: 3 1/8"  
B: 3" M: 3 5/8"  
2 Dz.



**L0371**  
Coupe Cocktail (8 Oz.)  
H: 5 5/8" T: 4 3/8"  
B: 3" M: 4 3/8"  
2 Dz.



**71086**  
Flute (5 ¾ Oz.)  
H: 7 ¾" T: 2"  
B: 2 ½" M: 2 ½"  
3 Dz.



**•00213**  
Cocktail (10 Oz.)  
H: 7 7/16" T: 4 3/4"  
B: 3" M: 4 3/4"  
1 Dz.

**•79320**  
Cocktail (10 Oz.)  
H: 7 7/16" T: 4 3/4"  
B: 3" M: 4 3/4"  
1 Dz.



**•D2024**  
Cocktail (7 ½ Oz.)  
H: 6 ¾" T: 4 ½"  
B: 3" M: 4 ½"  
1 Dz.

**•09232**  
Cocktail (7 ½ Oz.)  
H: 6 ¾" T: 4 ½"  
B: 3" M: 4 ½"  
1 Dz.

# Excalibur *cont'd.*



**12926**  
Iced Tea (16 ½ Oz.)  
H: 7 ¾" T: 2 13/16"  
B: 3" M: 3 ¼"  
2 Dz.



**04757**  
All Purpose Goblet (14 Oz.)  
H: 6 ¾" T: 2 7/8"  
B: 3" M: 3 3/16"  
2 Dz.



**71076**  
All Purpose Goblet (11 Oz.)  
H: 6 ¼" T: 2 ½"  
B: 3" M: 3 1/16"  
3 Dz.



**07395**  
Ballon Goblet (11 ½ Oz.)  
H: 5 ¾" T: 2 7/8"  
B: 2 ¾" M: 3 ¼"  
3 Dz.



**71078**  
Banquet Goblet (11 ½ Oz.)  
H: 5 ¼" T: 3"  
B: 2 7/8" M: 3 5/16"  
3 Dz.



**71079**  
Brandy (12 Oz.)  
H: 5 ¼" T: 2"  
B: 2 ½" M: 2 3/8"  
2 Dz.



**71093**  
Petite Cuvee (13 Oz.)  
H: 7" T: 2 ¾"  
B: 3" M: 3 5/16"  
2 Dz.



**71081**  
Grand Cuvee (13 Oz.)  
H: 8 1/8" T: 2 ¾"  
B: 3" M: 3 5/16"  
2 Dz.



**71092**  
Footed Hi Ball (8 Oz.)  
H: 5 ¼" T: 2 ¾"  
B: 2 5/8" M: 2 ¾"  
3 Dz.





**20875**  
Old Fashioned (7 Oz.)  
H: 3 1/6" T: 3"  
B: 2 1/8" M: 3"  
3 Dz.



**20874**  
Old Fashioned (9 Oz.)  
H: 3 1/4" T: 3 1/4"  
B: 2 5/16" M: 3 1/4"  
3 Dz.



**20873**  
Old Fashioned (10 1/2 Oz.)  
H: 3 1/2" T: 3 7/16"  
B: 2 1/2" M: 3 7/16"  
3 Dz.



**20871**  
Hi Ball (6 Oz.)  
H: 4" T: 2 1/2"  
B: 1 3/4" M: 2 1/2"  
3 Dz.



**20869**  
Hi Ball (8 Oz.)  
H: 4 9/16" T: 2 9/16"  
B: 1 7/8" M: 2 9/16"  
3 Dz.



**20868**  
Hi Ball (9 Oz.)  
H: 4 3/4" T: 2 1/16"  
B: 1 7/8" M: 2 1/16"  
3 Dz.



**20867**  
Hi Ball (10 1/2 Oz.)  
H: 5 1/16" T: 2 13/16"  
B: 2" M: 2 13/16"  
3 Dz.



**20866**  
Hi Ball (11 Oz.)  
H: 5 1/4" T: 2 7/8"  
B: 2" M: 2 7/8"  
3 Dz.



**20865**  
Beverage (12 1/2 Oz.)  
H: 5 1/16" T: 2 7/8"  
B: 2" M: 2 7/8"  
3 Dz.



**20864**  
Beverage (16 Oz.)  
H: 6" T: 3 1/8"  
B: 2 1/8" M: 3 1/8"  
3 Dz.

# *Arcadie*

The soft, delicate panels of the Arcadie collection offer a sense of simplicity.

The versatility of the line allows for easy cross functional service and the nestable design adds for easy space saving.





**Q2233**  
Rocks (3 Oz.)  
H: 2 1/2" T: 2 7/16"  
B: 1 1/4" M: 2 7/16"  
2 Dz.



**Q2234**  
Rocks (5 1/4 Oz.)  
H: 3" T: 3"  
B: 1 13/16" M: 3"  
2 Dz.



**Q2967**  
Rocks (8 Oz.)  
H: 3 3/8" T: 3 5/16"  
B: 2" M: 3 5/16"  
2 Dz.



**Q2750**  
Double Old Fashioned (11 3/4 Oz.)  
H: 3 7/8" T: 3 3/4"  
B: 2 3/8" M: 3 3/4"  
2 Dz.



**Q2751**  
Hi Ball (13 1/2 Oz.)  
H: 5" T: 3 1/16"  
B: 2 1/4" M: 3 1/16"  
2 Dz.



**Q3700**  
Saucer  
D: 4 1/2"  
2 Dz.  
Fits: Q2967, Q2234, Q2233



**Q3701**  
Saucer  
D: 5 1/2"  
2 Dz.  
Fits: Q2751, Q2750



## *Essentials*

A sleek and sophisticated barware line that features a slimming perspective and thin base.





**V3871**  
Rocks (7 ½ Oz.)  
H: 2 ¾" T: 3 ¼"  
B: 2 ⅞" M: 3 ¼"  
1 Dz.



**15012**  
Hi Ball (10 ½ Oz.)  
H: 6 ½" T: 2 ⅞"  
B: 2 ⅞" M: 2 ¼"  
2 Dz.



**Q1774**  
Collins (13 Oz.)  
H: 6 ⅞" T: 2 ¾"  
B: 2 ¼" M: 2 ¾"  
1 Dz.



**V3470**  
Rocks (12 ½ Oz.)  
H: 3 ½" T: 3 ¼"  
B: 2 ⅞" M: 3 ¼"  
2 Dz.



**N8901\***  
Grey Rocks (12 ½ Oz.)  
H: 3 ½" T: 3 ¼"  
B: 2 ⅞" M: 3 ¼"  
6 Pcs.



**V3473**  
Beverage (17 Oz.)  
H: 4 ⅞" T: 3 ½"  
B: 2 ¾" M: 3 ⅝"  
2 Dz.



**Q6480**  
Cooler (20 ¾ Oz.)  
H: 5 ¾" T: 3 ¼"  
B: 3 ¼" M: 3 ¼"  
1 Dz.

\*Color is applied via spray. Sprayed glassware can last up to 1,000 washes.

# Gotham

Our classic, multi-faceted design adds a splash of European café culture.



Shown Rocks (9 Oz.)



**J4094**  
Rocks (4 1/2 Oz.)  
H: 3 1/4" T: 2 3/4"  
B: 1 3/4" M: 2 3/4"  
3 Dz.



**J4096**  
Rocks (8 Oz.)  
H: 3 1/2" T: 3 1/4"  
B: 2 1/4" M: 3 1/2"  
3 Dz.



**J4097**  
Rocks (9 Oz.)  
H: 3 1/2" T: 3 1/4"  
B: 2 1/4" M: 3 5/8"  
3 Dz.



**J4099**  
Double Old Fashioned (12 Oz.)  
H: 3 3/4" T: 3 1/2"  
B: 2 1/2" M: 3 1/2"  
3 Dz.



**J4101**  
Beverage (10 Oz.)  
H: 4 3/4" T: 3"  
B: 2 1/4" M: 3 1/8"  
3 Dz.



**J4102**  
Beverage (12 Oz.)  
H: 4 3/4" T: 3 1/4"  
B: 2 1/2" M: 3 1/4"  
3 Dz.



**J4103**  
Beverage (14 Oz.)  
H: 5 1/8" T: 3 1/2"  
B: 2 1/2" M: 3 1/2"  
3 Dz.



**J4104**  
Cooler (16 Oz.)  
H: 6 1/4" T: 3 1/2"  
B: 2 1/2" M: 3 1/2"  
3 Dz.

Shown Cooler (12 Oz.), Tall Rocks (9 Oz.)



# Granite

Perfectly stackable, Granite is a multi-faceted, cafe-inspired glass.



**J2610**  
Rocks (5 ¼ Oz.)  
H: 3" T: 2 ¾"  
B: 2 ¾" M: 2 ¾"  
4 Dz.



**J2611**  
Rocks (7 Oz.)  
H: 3 ¼" T: 3 ½"  
B: 2 ¼" M: 3 ½"  
2 Dz.



**L7844**  
Double Old Fashioned (11 ¾ Oz.)  
H: 4 ¼" T: 3 ⅝"  
B: 2 ¾" M: 3 ⅝"  
2 Dz.



**V8924**  
Tall Rocks (9 Oz.)  
H: 3 ⅞" T: 3 ⅞"  
B: 2 ¾" M: 3 ⅞"  
3 Dz.



**J2605**  
Beverage (10 ½ Oz.)  
H: 5 ½" T: 2 ⅞"  
B: 2 ¾" M: 2 ⅞"  
2 Dz.



**43281**  
Beverage (16 Oz.)  
H: 6 ⅝" T: 3 ⅝"  
B: 2 ½" M: 3 ⅝"  
3 Dz.



**43279**  
Cooler (12 Oz.)  
H: 4 ⅞" T: 3 ¼"  
B: 2 ⅝" M: 3 ¼"  
3 Dz.



**J2603**  
Cooler (14 Oz.)  
H: 5 ½" T: 3 ½"  
B: 2 ¾" M: 3 ½"  
2 Dz.



# Mugs



**37684**  
Irish Coffee (8 ½ Oz.)  
H: 5 ½" T: 3"  
B: 2 1/16" M: 3 ½"  
2 Dz.



**11874**  
Irish Coffee (10 Oz.)  
H: 5 5/8" T: 2 3/4"  
B: 2 3/4" M: 4"  
2 Dz.



**53403**  
Irish Coffee (10 Oz.) **Non-Tempered**  
H: 5 5/8" T: 2 3/4"  
B: 2 3/4" M: 4"  
2 Dz.



**V7483**  
Mug (8 ½ Oz.)  
H: 3 ½" T: 2 5/16"  
B: 2 7/16" M: 4 1/16"  
6 Pcs.



**D9219**  
Nordic Mug (12 ½ Oz.)  
H: 3 3/4" T: 3 1/4"  
B: 3 ½" M: 4 7/8"  
2 Dz.

# Norvege



**V7462**  
Old Fashioned (6 ½ Oz.)  
H: 3 ½" T: 2 3/4"  
B: 2 1/8" M: 2 3/4"  
2 Dz.



**61697**  
Old Fashioned (8 ½ Oz.)  
H: 3 5/8" T: 3"  
B: 2 1/4" M: 3"  
6 Dz.



**V7529**  
Hi Ball (9 ½ Oz.)  
H: 4 ½" T: 2 3/4"  
B: 2" M: 2 3/4"  
2 Dz.



**61698**  
Beverage (10 3/4 Oz.)  
H: 5" T: 2 7/8"  
B: 2 ½" M: 2 7/8"  
6 Dz.





# Prysm

Slightly twisted square base collection with clean lines and optimal strength.



**E1515**  
Rocks (9 Oz.)  
H: 3 1/2" T: 3 5/8"  
B: 2 3/4" M: 3 5/8"  
4 Dz.



**E1514**  
Double Old Fashioned (12 1/2 Oz.)  
H: 3 3/4" T: 4"  
B: 3" M: 4"  
4 Dz.



**E1513**  
Beverage (12 Oz.)  
H: 5" T: 3 1/2"  
B: 2 1/2" M: 3 1/2"  
4 Dz.



**H0736**  
Cooler (16 Oz.)  
H: 5 3/4" T: 3 3/4"  
B: 2 3/4" M: 3 3/4"  
4 Dz.

Shown Beverage (12 Oz.)



# Rock Line

NEW

Featuring bold vertical lines, adding both a refined look and enhanced grip. The fully tempered treatment adds exceptional durability for high-traffic environments, with colored options providing easy differentiation.



Clear

Blue

Pink



**V7636**  
Rocks (12 Oz.)  
H: 3 3/4" T: 3 3/8"  
B: 2 1/4" M: 3 3/8"  
2 Dz.



**V7637**  
Hi Ball (12 1/4 Oz.)  
H: 5 3/8" T: 3"  
B: 2" M: 3"  
2 Dz.



**V8704**  
Blue Rocks (12 Oz.)  
H: 3 3/4" T: 3 3/8"  
B: 2 1/4" M: 3 3/8"  
2 Dz.



**V8705**  
Blue Hi Ball (12 1/4 Oz.)  
H: 5 3/8" T: 3"  
B: 2" M: 3"  
2 Dz.



**V8710**  
Pink Rocks (12 Oz.)  
H: 3 3/4" T: 3 3/8"  
B: 2 1/4" M: 3 3/8"  
2 Dz.



**V8711**  
Pink Hi Ball (12 1/4 Oz.)  
H: 5 3/8" T: 3"  
B: 2" M: 3"  
2 Dz.



# Rock Dew

NEW

With a subtle textured pattern, this collection adds style and a comfortable grip. Fully tempered for durability, these tumblers are built for busy environments, and the colored options make it easy to differentiate between beverages.



Clear

Blue

Pink



**V7638**  
Rocks (12 Oz.)  
H: 3 3/4" T: 3 3/8"  
B: 2 1/4" M: 3 3/8"  
2 Dz.



**V7639**  
Hi Ball (12 1/4 Oz.)  
H: 5 3/8" T: 3"  
B: 2" M: 3"  
2 Dz.



**V8706**  
Blue Rocks (12 Oz.)  
H: 3 3/4" T: 3 3/8"  
B: 2 1/4" M: 3 3/8"  
2 Dz.



**V8707**  
Blue Hi Ball (12 1/4 Oz.)  
H: 5 3/8" T: 3"  
B: 2" M: 3"  
2 Dz.



**V8712**  
Pink Rocks (12 Oz.)  
H: 3 3/4" T: 3 3/8"  
B: 2 1/4" M: 3 3/8"  
2 Dz.



**V8713**  
Pink Hi Ball (12 1/4 Oz.)  
H: 5 3/8" T: 3"  
B: 2" M: 3"  
2 Dz.

## *Stack Up*

Superior stackability makes this a go-to choice for space savings.





**H3858**  
Rocks (7 Oz.)  
H: 3 1/8" T: 3 1/4"  
B: 2 3/8" M: 3 1/4"  
1 Dz.



**L5216**  
Old Fashioned (8 3/4 Oz.)  
H: 3 5/8" T: 3 3/8"  
B: 2 1/4" M: 3 3/8"  
2 Dz.



**H3032**  
Old Fashioned (10 1/2 Oz.)  
H: 3 3/8" T: 3 5/8"  
B: 2 1/2" M: 3 5/8"  
1 Dz.



**H5169**  
Double Old Fashioned (12 Oz.)  
H: 3 7/8" T: 3 5/8"  
B: 2 3/4" M: 3 5/8"  
1 Dz.



**H3839**  
Hi Ball (10 Oz.)  
H: 5 3/8" T: 2 7/8"  
B: 2 1/8" M: 2 7/8"  
1 Dz.



**L5217**  
Hi Ball (11 3/4 Oz.)  
H: 5 1/2" T: 3 1/8"  
B: 2 1/8" M: 3 1/8"  
2 Dz.



**H3856**  
Beverage (14 Oz.)  
H: 5 5/8" T: 3 1/4"  
B: 2 1/4" M: 3 1/4"  
1 Dz.



**H3089**  
Cooler (16 Oz.)  
H: 5 3/4" T: 3 3/8"  
B: 2 3/8" M: 3 3/8"  
1 Dz.



**H3008**  
Cooler (21 Oz.)  
H: 6 3/8" T: 3 5/8"  
B: 2 3/8" M: 3 5/8"  
1 Dz.



# *Stack Up Cross*

NEW

Superior stackability and textured design helps to differentiate while remaining trendy. Mix and match with the stack up collection!





**V4140**  
 Rocks (7 Oz.)  
 H: 3 1/8" T: 3 1/4"  
 B: 2 3/8" M: 3 1/4"  
 2 Dz.



**V4139**  
 Rocks (8 3/4 Oz.)  
 H: 3 5/8" T: 3 3/8"  
 B: 2 1/4" M: 3 3/8"  
 2 Dz.



**V4138**  
 Hi Ball (11 3/4 Oz.)  
 H: 5 1/2" T: 3 1/8"  
 B: 2 1/8" M: 3 1/8"  
 2 Dz.





Shown Urbane Double Old Fashioned (14 Oz.)





**ARMORIM**  
HIGH RIM RESISTANCE

**ArmoRim** - Thermal strengthening after-process for rim reinforcement and chip resistance.

Urbane

90



Perfectly Stackable - Glassware designed to perfectly stack to optimize storage.



## *Urbane*

Long profile designs with slight curves and sturdy bottoms for increased durability at the bar. Built with a stackable ledge for efficient space saving.



**N0529**  
Whiskey/Shot (3 ½ Oz.)  
H: 3" T: 2 ⅝"  
B: 1 ⅝" M: 2 ⅝"  
1 Dz.



**N0523**  
Rocks (5 Oz.)  
H: 3 ¼" T: 2 ⅞"  
B: 1 ¾" M: 2 ⅞"  
1 Dz.



**N0530**  
Rocks (7 Oz.)  
H: 3 ⅝" T: 3 ⅛"  
B: 2" M: 3 ⅛"  
1 Dz.



**N0531**  
Rocks (9 Oz.)  
H: 3 ⅞" T: 3 ½"  
B: 2 ¼" M: 3 ½"  
1 Dz.



**N0512**  
Rocks (10 Oz.)  
H: 4" T: 3 ½"  
B: 2 ¼" M: 3 ½"  
1 Dz.



**N0524**  
Double Old Fashioned (12 Oz.)  
H: 4 ⅞" T: 3 ¾"  
B: 2 ⅜" M: 3 ¾"  
1 Dz.



**N0527**  
Double Old Fashioned (14 Oz.)  
H: 4 ¼" T: 3 ⅞"  
B: 2 ½" M: 3 ⅞"  
1 Dz.



**N0513**  
Hi Ball (10 Oz.)  
H: 6 ¼" T: 2 ⅞"  
B: 2" M: 2 ⅞"  
1 Dz.



**N0521**  
Beverage (12 Oz.)  
H: 6 ¼" T: 3"  
B: 2 ⅞" M: 3"  
1 Dz.



**N0528**  
Beverage (14 Oz.)  
H: 6 ⅝" T: 3 ¼"  
B: 2 ¼" M: 3 ¼"  
1 Dz.



**N0520**  
Cooler (16 Oz.)  
H: 7" T: 3 ⅝"  
B: 2 ⅜" M: 3 ⅝"  
1 Dz.







EVERYDAY  
CLASSICS

**Everyday Classics** - A glass for every occasion. Discover the limitless possibilities with Arcoroc's glassware collections, where creativity and customer desires take center stage. Embracing both practicality and functionality, our glassware encourages you to unleash your imagination. Create extraordinary moments, curate unforgettable experiences, and celebrate in style. No matter the occasion, let us help you make it a remarkable one.

Broadway	94
Imperator <i>NEW</i>	96
Elysees <i>NEW</i>	96
Quadrilles <i>NEW</i>	96
Luxe <i>NEW</i>	97
Monti <i>NEW</i>	98
Aristocrat	100
Brixton <i>NEW</i>	101
Cabernet	102
Cooler	103
Islande	104
Mason Jar	105
Perfection	105
Salto	106
Sheltand	108
Wine Bottom Tumblers	109

ARCOPRIME

Universal	110
Straight Sided	110



Perfectly Stackable - Glassware designed to perfectly stack to optimize storage.

# *Broadway*

Strikingly beautiful cut glass adds stylish sophistication to your beverage service with a vintage touch.





**Q7932**  
Vintage Cocktail (8 ¼ Oz.)  
H: 7 ¾" T: 3 ½"  
B: 2 ¾" M: 3 ½"  
2 Dz.



**P8795**  
Cocktail (7 Oz.)  
H: 6 ½" T: 4 ½"  
B: 3" M: 4 ½"  
1 Dz.



**P8796**  
Coupe Cocktail (8 Oz.)  
H: 5 ½" T: 4 ½"  
B: 3" M: 4 ½"  
1 Dz.



**P8821**  
Gin Cocktail (19 ½ Oz.)  
H: 7 ½" T: 4 ¼"  
B: 3 ¼" M: 4 ¼"  
1 Dz.



**V2910**  
Shot (2 Oz.)  
H: 2 ¾" T: 1 ⅞"  
B: 1 ⅛" M: 1 ⅞"  
2 Dz.



**FP320**  
Rocks (7 ½ Oz.)  
H: 3 ½" T: 3"  
M: 3" B: 2 ⅝"  
2 Dz.



**L7254**  
Rocks (10 ½ Oz.)  
H: 3 ½" T: 3 ⅜"  
B: 3" M: 3 ⅜"  
2 Dz.



**V5996**  
Mauve Rocks (10 ½ Oz.)  
H: 3 ½" T: 3 ⅜"  
B: 3" M: 3 ⅜"  
2 Dz.



**V5998**  
Blue Rocks (10 ½ Oz.)  
H: 3 ½" T: 3 ⅜"  
B: 3" M: 3 ⅜"  
2 Dz.



**FP321**  
Double Rocks (12 ½ Oz.)  
H: 3 ¾" T: 3 ⅝"  
M: 3 ⅝" B: 2 ⅞"  
2 Dz.



**L7256**  
Hi Ball (9¼ Oz.)  
H: 5 ¼" T: 2 ⅝"  
B: 2 ¼" M: 2 ⅝"  
2 Dz.



**L7255**  
Hi Ball (12 Oz.)  
H: 5 ¾" T: 3"  
B: 2 ½" M: 3"  
2 Dz.



**P1470**  
Beverage (15 Oz.)  
H: 6 ½" T: 3 ⅝"  
B: 2 ¾" M: 3 ⅝"  
2 Dz.



**FP332**  
Beaker (24 Oz.)  
H: 6" T: 4 ⅝"  
M: 4 ¾" B: 3 ⅝"  
6 Pcs.



The classic designs of Emperor, Elysees, and Quadrille are sure to make a statement. Each glass features a traditional cut glass design that is both timeless and sophisticated, perfect for enhancing the presentation of fine spirits.

## *Imperator* NEW

The imperator tumbler features bold vertical facets around the base for a striking design and comfortable grip—perfect for enhancing the presentation of spirits.



**V8953**  
Old Fashioned (10 ¼ Oz.)  
H: 3 ⅝" T: 3 ¼"  
M: 3 ¼" B: 2 ½"  
2 Dz.

## *Elysees* NEW

With its elegant vertical cuts extending gracefully up the glass, the Elysees tumbler offers a refined touch that elevates both the grip and presentation of your finest spirits.



**V8954**  
Old Fashioned (10 ½ Oz.)  
H: 3 ⅝" T: 3 ⅝"  
M: 3 ⅝" B: 2 ¾"  
2 Dz.

## *Quadrille* NEW

The Quadrille tumbler boasts bold, intricate cuts around the base, creating a striking design that ensures a comfortable grip and enhances the presentation of your finest spirits.



**V8956**  
Old Fashioned (10 ¼ Oz.)  
H: 3 ½" T: 3 ¼"  
M: 3 ¼" B: 2 ⅝"  
2 Dz.



*Luxe* **NEW**

The strong vertical lines of Luxe add a stylish touch and provide a secure grip. The cut design elevates the drinking experience by highlighting and intensifying the bold, complex flavors of the beverages served.



**FP683**  
Rocks (10 ½ Oz.)  
H: 3 ¾" T: 3 ¼"  
M: 3 ¼" B: 3 ⅛"  
2 Dz.



**FP684**  
Hi Ball (12 Oz.)  
H: 6" T: 2 ¾"  
M: 2 ¾" B: 2 ¾"  
2 Dz.

# Monti

NEW

The classic, ornate stem of the Monti collection will transport you back to the good old days. Serve your classic cocktails with a twist, whether that's the addition of low-proof bitters or other unexpected ingredients!





**Q8201**  
Coupe (9 Oz.)  
H: 6" T: 3 1/8"  
B: 3" M: 3 1/2"  
1 Dz.



**Q8701**  
Cocktail (9 Oz.)  
H: 6 3/4" T: 3 1/8"  
B: 2 1/2" M: 3 1/8"  
1 Dz.



**Q1325**  
Martini (7 Oz.)  
H: 6 1/8" T: 4 1/2"  
B: 3" M: 4 1/2"  
1 Dz.



# *Aristocrat*

Classic clean, straight walled Aristocrat is the perfect all around tumbler. From in-room to old fashioned cocktails, Aristocrat is versatile and sleek.



**53224**  
Old Fashioned (10 ½ Oz.)  
H: 3 ½" T: 3 ¾"  
B: 3" M: 3 ¾"  
3 Dz.



**53232**  
Double Old Fashioned (14 Oz.)  
H: 4 ½" T: 3 ¾"  
B: 3 ½" M: 3 ¾"  
3 Dz.



**53205**  
Beverage (13 Oz.)  
H: 5 ½" T: 2 7/8"  
B: 2 ½" M: 2 7/8"  
3 Dz.



**53214**  
Cooler (16 Oz.)  
H: 6 ¼" T: 2 7/8"  
B: 2 ½" M: 2 7/8"  
3 Dz.

*Brixton* **NEW**

Unique design for an elevated experience. Pairs well with Aristocrat.



Shown Double Rocks (12 ½ Oz.)

## ARCOROC



**P4188**  
Rocks (10 ½ Oz.)  
H: 4 T: 3 ¼" M: 3 ¼" B: 2 ⅝"  
1 Dz.



**P9067**  
Double Rocks (12 ½ Oz.)  
H: 4 ⅜" T: 3 ⅜" M: 3 ⅜"  
2 Dz.



**Q8947**  
Hi Ball (10 ½ Oz.)  
H: 6" T: 2 ¼" M: 2 ¼"  
1 Dz.

# Cabernet

Curved and simple, Cabernet is the perfect complement to Arocroc stemware.



Shown Cooler (17 Oz.)



**47346**  
Cordial (2 ½ Oz.)  
H: 3 ½" T: 1 ½"  
B: 1 ¾" M: 1 ⅝"  
4 Dz.



**10007**  
Rocks (10 ½ Oz.)  
H: 3 ¼" T: 3 ⅙"  
B: 2 ¾" M: 3 ⅜"  
3 Dz.



**17198**  
Cooler (17 Oz.)  
H: 5 7/8" T: 2 3/4"  
B: 2 1/2" M: 3 1/8"  
1 Dz.

## Cooler

Meet your universal glassware companion. Whether it's a frothy beer or trendy cocktail, this glass can serve it all.



Shown Can Cooler (16 Oz.)



**D0130**  
Cooler (14 1/2 Oz.)  
H: 6 3/8" T: 2 3/8"  
B: 2" M: 2 7/8"  
2 Dz.



**E5458**  
Can Cooler (16 Oz.)  
H: 5 1/4" T: 2 3/8"  
B: 2 1/2" M: 3"  
3 Dz.



**L4865**  
Tall Can Cooler (16 Oz.)  
H: 6 1/2" T: 2 1/4"  
B: 2 1/2" M: 2 5/8"  
2 Dz.

# *Islande*

A clean profile coupled with a heavy sham makes this line ideal for both casual gatherings and formal events. The heavy sham adds stability and perceived value.



Shown Double Old Fashioned (12 ¾ Oz.) | Collins (13 Oz.) | Hi Ball (15 ½ Oz.)





**Q5761**  
Cordial (2 ¼ Oz.)  
H: 4 ½" T: 1 ½"  
B: 1 ¾" M: 1 ½"  
4 Dz.



**J4238**  
Whiskey (3 ¼ Oz.)  
H: 3 7/16" T: 2"  
B: 1 7/8" M: 2"  
2 Dz.



**N6643**  
Juice (5 ¼ Oz.)  
H: 4" T: 2 ½"  
B: 2" M: 2 ½"  
2 Dz.



**D0616**  
Old Fashioned (7 Oz.)  
H: 3 ¼" T: 2 ¾"  
B: 2 5/8" M: 2 ¾"  
4 Dz.



**12652**  
Old Fashioned (8 ½ Oz.)  
H: 3 ¾" T: 3 ½"  
B: 3" M: 3 ½"  
4 Dz.



**V3469**  
Old Fashioned (10 Oz.)  
H: 3 5/8" T: 3 ½"  
B: 3" M: 3 ½"  
2 Dz.



**V3476**  
Double Old Fashioned (12 ¾ Oz.)  
H: 3 ¾" T: 3 ½"  
B: 3 5/16" M: 3 ½"  
2 Dz.



**V3472**  
Hi Ball (10 Oz.)  
H: 5 5/8" T: 2 ½"  
B: 2 ¼" M: 2 ½"  
2 Dz.



**D0575**  
Hi Ball (11 Oz.)  
H: 6 ½" T: 2 ¾"  
B: 2 ½" M: 2 ¾"  
4 Dz.



**V3475**  
Collins (13 Oz.)  
H: 6 ¾" T: 2 ½"  
B: 2 ¼" M: 2 ½"  
2 Dz.



**Q7781**  
Hi Ball (15 ½ Oz.)  
H: 6 ¼" T: 2 7/8"  
B: 2 ½" M: 2 7/8"  
1 Dz.





## Mason Jar

A classic jar design perfect for serving unique cocktails, soft drinks, beer or desserts! Versatile vessel with a rustic aesthetic.



**FK203**  
Mason Jar with Handle (16 ½ Oz.)  
H: 5 ¼" T: 2 ⅝"  
B: 2 ⅝" M: 4 ⅛"  
1 Dz.

## Perfection

Embrace the charm and versatility of the Perfection collection. Seamlessly transition from cocktails to water service to wine.



**C8832**  
Tumbler (9 Oz.)  
H: 3 ¾" T: 2 ¼"  
B: 1 ½" M: 2 ¾"  
1 Dz.



**P6284**  
Tumbler (12 Oz.)  
H: 4 ⅜" T: 2 ½"  
B: 1 ¾" M: 3 ⅝"  
1 Dz.



**C8303**  
Tumbler (15 Oz.)  
H: 4 ⅜" T: 2 ⅝"  
B: 1 ⅞" M: 3 ⅝"  
1 Dz.



**C8304**  
Tumbler (21 Oz.)  
H: 5" T: 3"  
B: 2 ¼" M: 3 ½"  
1 Dz.



**H4870**  
Flute (9 Oz.)  
H: 5 ⅝" T: 2 ⅞"  
B: 1 ½" M: 2 ⅞"  
1 Dz.

# Salto

The elegant arched sides creates a glass that fits perfectly in all hands.



Shown Hi Ball (11 3/4 Oz.)



**V3870**  
Cordial (2 Oz.)  
H: 2 1/2" T: 1 1/16"  
B: 1 3/8" M: 1 7/8"  
4 Dz.



**G2562**  
Rocks (10 3/4 Oz.)  
H: 3 1/4" T: 3 1/8"  
B: 2 1/4" M: 3 1/2"  
4 Dz.



**N5812**  
Hi Ball (11 3/4 Oz.)  
H: 4 3/4" T: 2 1/2"  
B: 1 15/16" M: 3"  
2 Dz.



**N5828**  
Cooler (17 Oz.)  
H: 5 3/4" T: 2 1/2"  
B: 2" M: 3 1/8"  
2 Dz.

# Shetland

Shetland, a true icon of versatility, seamlessly transforms from water to beer or cocktail service with its adaptable design. The heavy sham adds value and stability.

Shown Hi Ball (12 Oz.)



**V5926**  
Old Fashioned (8 ½ Oz.)  
H: 3 ½" T: 3 ½"  
B: 2 ¾" M: 3 ½"  
2 Dz.



**E1907**  
Old Fashioned (10 ¾ Oz.)  
H: 3 ⅞" T: 3 ¾"  
B: 2 ½" M: 3 ¾"  
4 Dz.



**79736**  
Hi Ball (7 ½ Oz.)  
H: 4 ¾" T: 2 ⅜"  
B: 1 ¾" M: 2 ⅜"  
4 Dz.



**V5927**  
Hi Ball (12 Oz.)  
H: 5 ½" T: 3 ¼"  
B: 2" M: 3 ¼"  
4 Dz.



**G3611**  
Hi Ball (14 Oz.)  
H: 5 ¾" T: 3 ⅝"  
B: 2 ⅞" M: 3 ⅝"  
4 Dz.

## *Wine Bottom Tumblers*

The Art of Upcycling. The wine bottle design repurposed into a unique drinking vessel for a memorable beverage presentation. The distinctive base indentation gives a rustic appeal to this charming drinking glass.



**FJ060**  
Clear Tumbler (12 Oz.)  
H: 4" T: 3"  
B: 3" M: 3"  
1 Dz.



**FJ061**  
Clear Tumbler (16 Oz.)  
H: 5 1/2" T: 3"  
B: 3" M: 3"  
1 Dz.



**FK258**  
Green Tumbler (12 Oz.)  
H: 4" T: 3"  
B: 3" M: 3"  
1 Dz.



**FK259**  
Green Tumbler (16 Oz.)  
H: 5 1/2" T: 3"  
B: 3" M: 3"  
1 Dz.



**FJ063**  
Amber Tumbler (12 Oz.)  
H: 4" T: 3"  
B: 3" M: 3"  
1 Dz.



**FJ062**  
Amber Tumbler (16 Oz.)  
H: 5 1/2" T: 3"  
B: 3" M: 3"  
1 Dz.





**Q2518**  
 Universal Wine (12 Oz.)  
 H: 7 15/16" T: 2 1/2"  
 B: 2 1/16" M: 3 3/16"  
 1 Dz.



**Q2517**  
 Universal Wine (16 Oz.)  
 H: 8 3/4" T: 2 3/4"  
 B: 3 1/16" M: 3 7/16"  
 1 Dz.



**Q2505**  
 Universal Wine (19 Oz.)  
 H: 9 1/16" T: 2 15/16"  
 B: 3 1/16" M: 3 11/16"  
 1 Dz.



**Q2504**  
 Flute (5 3/4 Oz.)  
 H: 7 7/8" T: 1 15/16"  
 B: 2 5/8" M: 2 3/16"  
 1 Dz.



**Q2540**  
 Straight Sided OF (7 1/2 Oz.)  
 H: 3 1/2" T: 2 7/8"  
 B: 2 5/8" M: 2 1/16"  
 1 Dz.



**Q2539**  
 Straight Sided OF (10 1/2 Oz.)  
 H: 3 1/2" T: 3 3/16"  
 B: 3" M: 3 3/16"  
 1 Dz.



**Q2538**  
 Straight Sided DOF (14 Oz.)  
 H: 4 1/8" T: 3 3/8"  
 B: 3 1/8" M: 3 3/8"  
 1Dz.



**Q2537**  
 Straight Sided Cooler (13 Oz.)  
 H: 5 1/2" T: 2 7/8"  
 B: 2 1/2" M: 2 7/8"  
 1 Dz.



**Q2536**  
 Straight Sided Beverage (16 Oz.)  
 H: 6 1/4" T: 2 7/8"  
 B: 2 1/2" M: 2 7/8"  
 1 Dz.



**Q2542**  
 Mixing Glass (16 Oz.)  
 H: 5 3/4" T: 3 1/2"  
 B: 2 3/8" M: 3 1/2"  
 2 Dz.









# Occasion

Glassware for any occasion, from buffet, cocktail experiences, beer garden to in-room service.

Sparkling Wine	114
Spirits	120
Beer	134
In-Room Tumblers	143
Decanters & Carafes	144
Mix	150
Outdoor Perfect	158



Krysta® – High-performance crystal glass. Superior strength, complete transparency, long-lasting brilliance and perfect acoustics.



Fully Tempered – More resistant to mechanical and thermal shock than regular annealed glass; up to 5X more resistant to breakage.



Perfectly Stackable - Glassware designed to perfectly stack to optimize storage.



Head Booster - Technology and textured bottom that boosts a beers head and keeps the head longer for a better drinking experience.



S.A.N. Plastic - Fully recyclable, BPA-Free with water vents at the bottom to allow for proper drainage.



ArmorRim + Sheer Rim - Thermal strengthening after-process for rim reinforcement and chip resistance.





***SPARKLING  
WINE***

# Sparkling Wine



NEW



**FP633**  
Grace Flute (8 Oz.)  
H: 9 1/2" T: 1 3/16"  
M: 2 5/16" B: 2 3/4"  
2 Dz.

NEW



**V2697\***  
Symétrie Flute (7 1/2 Oz.)  
H: 9 1/2" T: 2 1/2"  
B: 2 3/4" M: 2 1/4"  
2 Dz.

NEW



**Q9080\***  
Distinction Flute (7 3/4 Oz.)  
H: 9 1/8" T: 1 3/4"  
B: 2 3/4" M: 2 5/8"  
2 Dz.



**L3678**  
Sublym Coupe Cocktail (8 Oz.)  
H: 7 7/8" T: 4 1/2"  
B: 3" M: 4 1/2"  
2 Dz.

NEW



**Q7785\***  
Coupe Cocktail (7 Oz.)  
H: 6" T: 3 1/16"  
B: 2 3/4" M: 3 1/16"  
2 Dz.



**L5641**  
Sequene Coupe Cocktail (7 3/4 Oz.)  
H: 5 7/8" T: 4 3/8"  
B: 3" M: 4 3/8"  
1 Dz.



NEW



**V2823\***  
Evidence Flute (5 ½ Oz.)  
H: 7 ½" T: 1 ¾"  
B: 2 ⅞" M: 2 ⅜"  
2 Dz.



**48024\***  
Cabernet Flute (6 Oz.)  
H: 8 ⅞" T: 2"  
B: 2 ¾" M: 2 ¼"  
2 Dz.



**L5640\***  
Sequence Flute (6 Oz.)  
H: 8 ¼" T: 1 ⅞"  
B: 2 ¾" M: 2 ¼"  
1 Dz.



**E7700\***  
Exalt Flute (6 ¼ Oz.)  
H: 8 ¼" T: 2"  
B: 2 ¾" M: 2 ⅜"  
2 Dz.



**L2762\***  
Sublym Flute (7 ½ Oz.)  
H: 9 ½" T: 1 ¾"  
B: 2 ¾" M: 2 ¼"  
2 Dz.



**U1051\***  
Open Up Flute (6 ¾ Oz.)  
H: 9" T: 2 ⅜"  
B: 2 ⅞" M: 2 ¾"  
2 Dz. | 4 Oz. Pour Line



**D0796\***  
Cabernet Flute (8 Oz.)  
H: 9 ¼" T: 2"  
B: 2 ¾" M: 2 ⅞"  
2 Dz.



**J8907\***  
Reveal' Up Soft Flute (8 Oz.)  
H: 9 ¼" T: 1 ¾"  
B: 2 ¾" M: 2 ⅞"  
2 Dz.



**Q1151\***  
Exaltation Flute (10 ¼ Oz.)  
H: 8 ⅞" T: 2 ⅞"  
B: 2 ⅞" M: 3 ⅞"  
2 Dz.



**J8908\***  
Reveal Up Soft Wine (11 Oz.)  
H: 8 ½" T: 2"  
B: 3" M: 3 ¼"  
2 Dz.





**H8466\*** ●  
Malea Brio Flute (3 Oz.)  
H: 6 1/16" T: 1 7/8"  
B: 2 1/8" M: 2 1/4"  
2 Dz.



**J1478\*** ●  
Malea Brio Flute (5 1/4 Oz.)  
H: 7 7/8" T: 2 1/8"  
B: 2 3/8" M: 2 5/8"  
2 Dz.



**E6125** •  
Outdoor Perfect Flute (5 Oz.)  
H: 8 1/2" T: 2"  
B: 2 3/4" M: 2 1/4"  
3 Dz.



**V3874**  
Coupe Cocktail (5 1/2 Oz.)  
H: 4 3/4" T: 3 3/8"  
B: 2 3/4" M: 3 1/2"  
4 Dz.



**H2090\*** •  
Flute (5 1/4 Oz.)  
H: 8 3/4" T: 1 3/4"  
B: 2 1/2" M: 2 1/8"  
2 Dz.



**71086** •  
Excalibur Flute (5 3/4 Oz.)  
H: 7 3/4" T: 2"  
B: 2 1/2" M: 2 1/2"  
3 Dz.



**P8793** •  
Romeo Flute (5 3/4 Oz.)  
H: 7 7/8" T: 2"  
B: 2 3/8" M: 2 1/8"  
1 Dz.



**N5082\*** •  
V. Juliette Flute (7 3/4 Oz.)  
H: 8 5/8" T: 1 7/8"  
B: 2 7/8" M: 2 5/8"  
2 Dz.



**L0371** •  
Excalibur Coupe Cocktail (8 Oz.)  
H: 5 5/8" T: 4 3/8"  
B: 3" M: 4 3/8"  
2 Dz.



**ARMORIM**  
HIGH RIM RESISTANCE



\*EFFERVESCENCE PLUS

OCCASION // SPARKLING WINE

# *SPIRITS*





# *Experience the World of Spirits*

From colorful drinks to on the rocks, selecting the right glass for your spirit, cocktail, non-alcoholic or island drink is very important.

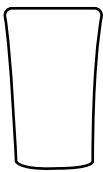

## **SHOTS**

Ideal for small servings of various spirits. Shot glasses feature a thick base and a narrow opening, allowing for easy handling and controlled pouring.



## **WHISKEY**

A staple versatile glass with sleek and simple designs made for complex cocktails or a spirit straight-up.

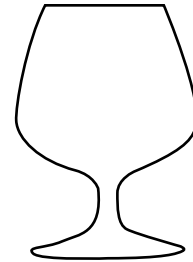

## **DIGESTIF**

Digestifs are sipped slowly after a meal. The tulip shaped glasses aids in boosting aromas, allowing the drinker to savor the complex flavors.

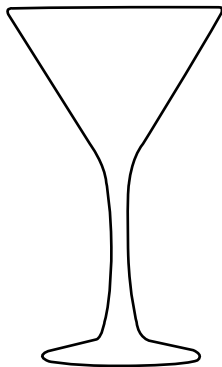

## **MARTINI**

The iconic angled bowl showcases the visual appeal of the cocktail and enhances the aroma, while the stem prevents the hand from warming the chilled martini.

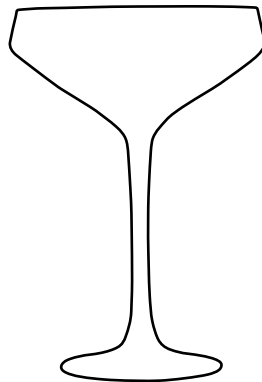

## **COUPE**

The coupe is a vintage classic that has a shallow bowl that boosts aromas and allows maximum surface area for garnishes for a variety of cocktails.

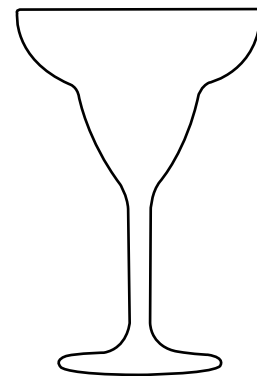

## **OCCASION**

Occasion glasses offer a visual appeal and experience from classic margaritas to island drinks. A wide variety of shapes and cocktail specific shapes.

# Coupes



NEW



**Q3702**  
Nick and Nora Cocktail (5 ¼ Oz.)  
H: 5 5/8" T: 2 3/4"  
B: 2 3/8" M: 2 3/4"  
2 Dz.

NEW



**Q7785\***  
Coupe Cocktail (7 Oz.)  
H: 6" T: 3 1/16"  
B: 2 3/4" M: 3 1/16"  
2 Dz.



**L3678**  
Sublym Coupe Cocktail (8 Oz.)  
H: 7 1/8" T: 4 1/2"  
B: 3" M: 4 1/2"  
2 Dz.



**L5641**  
Sequence Coupe Cocktail (7 ¾ Oz.)  
H: 5 7/8" T: 4 3/8"  
B: 3" M: 4 3/8"  
1 Dz.

NEW



**V1171**  
Symétrie Coupe (8 Oz.)  
H: 7 1/8" T: 4 1/2"  
B: 3" M: 4 1/2"  
2 Dz.



**N6815**  
Cabernet Champagne Coupe (10 Oz.)  
H: 6 3/4" T: 4 3/8"  
B: 2 7/8" M: 4 3/8"  
1 Dz.





**V3874**  
Coupe Cocktail (5 ½ Oz.)  
H: 4 ¾" T: 3 ¾"  
B: 2 ¾" M: 3 ½"  
4 Dz.



**CA030**  
Chris Adams Coupe Cocktail (6 Oz.)  
H: 5 ¾" T: 3 ½"  
B: 2 7/8" M: 3 ½"  
2 Dz.



**CA504**  
Chris Adams Coupe Cocktail (6 Oz.)  
H: 5 ¾" T: 3 ½"  
B: 2 7/8" M: 3 ½"  
2 Dz.



**CA031**  
Chris Adams Coupe Cocktail (6 Oz.)  
H: 5 7/8" T: 3 ½"  
B: 2 7/8" M: 3 ½"  
2 Dz.

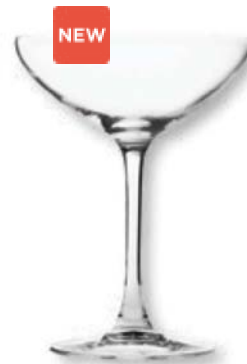

**V2761** ●  
Romeo Cocktail (8 Oz.)  
H: 5 7/8" T: 4 1/8"  
B: 3" M: 4 1/8"  
1 Dz.



**P8796**  
Broadway Coupe Cocktail (8 Oz.)  
H: 5 ½" T: 4 ½"  
B: 3" M: 4 ½"  
1 Dz.



**L0371** ●  
Excalibur Coupe Cocktail (8 Oz.)  
H: 5 5/8" T: 4 3/8"  
B: 3" M: 4 3/8"  
2 Dz.



**ARMORIM**  
HIGH RIM RESISTANCE



# Martini

Chef&Sommelier



**P3882**  
Cabernet Cocktail (7 ½ Oz.)  
H: 6 ¾" T: 4 ½"  
B: 3" M: 4 ½"  
1 Dz.



**N6831**  
Cabernet Cocktail (10 Oz.)  
H: 7 ½" T: 4 ¾"  
B: 3" M: 4 ¾"  
1 Dz.



Shown Cabernet Cocktail (10 Oz.)





**V2760** •  
Romeo Cocktail (5 ½ Oz.)  
H: 5 ¾" T: 2 ¾"  
B: 2 ¾" M: 2 ¾"  
1 Dz.



**V4025** •  
Romeo Martini (5 Oz.)  
H: 5 ¾" T: 2 ¾"  
B: 2 ¾" M: 2 ¾"  
1 Dz.



**Q1325**  
Monti Martini (7 Oz.)  
H: 6 ½" T: 4 ½"  
B: 3" M: 4 ½"  
1 Dz.



**P8795**  
Broadway Cocktail (7 Oz.)  
H: 6 ½" T: 4 ½"  
B: 3" M: 4 ½"  
1 Dz.



**D2024** •  
Excalibur Cocktail (7 ½ Oz.)  
H: 6 ¾" T: 4 ½"  
B: 3" M: 4 ½"  
1 Dz.



**00213** •  
Excalibur Cocktail (10 Oz.)  
H: 7 ¾" T: 4 ¾"  
B: 3" M: 4 ¾"  
1 Dz.

**09232**  
Excalibur Cocktail (non-tempered) (7 ½ Oz.)  
H: 6 ¾" T: 4 ½"  
B: 3" M: 4 ½"  
1 Dz.

**79320**  
Excalibur Cocktail (non-tempered) (10 Oz.)  
H: 7 ¾" T: 4 ¾"  
B: 3" M: 4 ¾"  
1 Dz.



**N6216**  
Kyoto (5 Oz.)  
H: 3" T: 3 ⅝"  
B: 2 ¾" M: 3 ⅝"  
16 Pcs.



**Q7932**  
Broadway Vintage Cocktail (8 ¼ Oz.)  
H: 7 ½" T: 3 ½"  
B: 3" M: 3 ½"  
1 Dz.



**E6132** •  
Outdoor Perfect Cocktail (10 Oz.)  
H: 7 ⅝" T: 4 ¾"  
B: 3 ¼" M: 4 ⅝"  
2 Dz.



# Occasion



**71093** ●  
Excalibur Petite Cuvee (13 Oz.)  
H: 7" T: 2 3/4"  
B: 3" M: 3 5/16"  
2 Dz.



**71081** ●  
Excalibur Grand Cuvee (13 Oz.)  
H: 8 1/8" T: 2 3/4"  
B: 3" M: 3 5/16"  
2 Dz.



**P8821**  
Broadway Gin Cocktail (19 1/2 Oz.)  
H: 7 1/2" T: 4 1/4"  
B: 3 1/4" M: 4 1/4"  
1 Dz.



**N2760**  
G&T Cocktail (24 Oz.)  
H: 7 3/4" T: 3 3/4"  
B: 3 1/4" M: 4 1/2"  
1 Dz.



Shown Romeo Margarita (12 Oz.)



**V4222** •  
Romeo Margarita (12 Oz.)  
H: 6 1/16" T: 4 5/8"  
B: 3" M: 4 5/8"  
1 Dz.



**E6127** •  
Outdoor Perfect Margarita (12 Oz.)  
H: 6 7/8" T: 4 7/8"  
B: 3 1/4" M: 4 3/4"  
2 Dz.



**C2172**  
Hurricane (15 Oz.)  
H: 8 1/4" T: 3 1/8"  
B: 3" M: 3 1/8"  
2 Dz.



**E6128** •  
Outdoor Perfect Hurricane (14 3/4 Oz.)  
H: 9 1/8" T: 2 7/8"  
B: 3" M: 2 7/8"  
3 Dz.



**ARMORIM**  
HIGH RIM RESISTANCE +



# Moscow Mules

Striking metallic presentations to serve your classic Moscow Mules, Ginger Beers and Beverages. This vessel can also be used for your appetizer needs like french fries, zucchini sticks, and more.



**FK364**  
Copper Moscow Mule (16 Oz.)  
H: 4" T: 3 3/8"  
B: 2 1/4" M: 4 3/8"  
1 Dz.



**FK368**  
Copper Hammered Moscow Mule (16 Oz.)  
H: 4" T: 3 3/8"  
B: 2 1/4" M: 4 3/8"  
1 Dz.



**FK492**  
Black Moscow Mule (16 Oz.)  
H: 4" T: 3 3/8"  
B: 2 1/4" M: 4 3/8"  
1 Dz.



**FK493**  
Black Hammered Moscow Mule (16 Oz.)  
H: 4" T: 3 3/8"  
B: 2 1/4" M: 4 3/8"  
1 Dz.



# Shots



Shown Hot Shot (1 ¼ Oz.), Shot Glass (1 ¼ Oz.)



**N0529**  
Urbane Whiskey/Shot (3 ½ Oz.)  
H: 3" T: 2 ¾"  
B: 1 ⅝" M: 2 ⅝"  
1 Dz.



**21554**  
Hot Shot (1 ¼ Oz.)  
H: 2 ¾" T: 1 ¾"  
B: 1 ⅝" M: 1 ¾"  
2 Dz.



**00016**  
Shot Glass (1 ¼ Oz.)  
H: 2" T: 1 ⅝"  
B: 1" M: 1 ⅝"  
2 Dz.



**H5057**  
Shot Glass (1 ¾ Oz.)  
H: 2 ¼" T: 1 ⅝"  
B: 1 ⅝" M: 1 ⅝"  
6 Dz.



**N5834**  
Salto Cordial (2 Oz.)  
H: 2 ½" T: 1 ⅞"  
B: 1 ⅜" M: 1 ⅞"  
4 Dz.



**V2910**  
Broadway Shot (2 Oz.)  
H: 2 ¾" T: 1 ⅞"  
B: 1 ⅝" M: 1 ⅞"  
2 Dz.



**G2639**  
Hot Shot (2 ½ Oz.)  
H: 3 ⅝" T: 2 ⅞"  
B: 1 ½" M: 2 ⅞"  
4 Dz.



**19188**  
Square Shot Glass (2 ½ Oz.)  
H: 2 ⅞" T: 2 ⅝"  
B: 2" M: 2 ⅝"  
6 (1 Dz. Packs)



**C3966**  
Tall Square Shot Glass (2 ¾ Oz.)  
H: 3 ¾" T: 1 ⅞"  
B: 1 ⅝" M: 1 ⅞"  
6 Dz.



**Q5761**  
Cordial (2 ¼ Oz.)  
H: 4 ¼" T: 1 ½"  
B: 1 ⅜" M: 1 ½"  
4 Dz.  
Old SKU: 40375



**47346**  
Cabernet Cordial (2 ½ Oz.)  
H: 3 ½" T: 1 ½"  
B: 1 ⅜" M: 1 ⅝"  
4 Dz.

# Whiskey

A curated collection of Whiskey favorites.



**G3659**  
Cabernet Sheer Rocks (7 Oz.)  
H: 2 3/4" T: 2 3/4"  
B: 2 3/8" M: 2 3/4"  
2 Dz.  
ALSO AVAILABLE IN:  
**G3666** (10 1/2 Oz.)  
**L2370** (12 1/2 Oz.)



**L5758**  
Sequence Rocks (10 1/2 Oz.)  
H: 3 1/2" T: 3"  
B: 2 1/4" M: 3 3/8"  
1 Dz.  
ALSO AVAILABLE IN:  
**L5757** (8 1/2 Oz.)  
**L5756** (13 1/2 Oz.)



**Q4353**  
Architecte Rocks (10 3/4 Oz.)  
H: 3 7/8" T: 3 1/2"  
B: 2 3/4" M: 3 1/2"  
1 Dz.



**Q4354**  
Rendez-Vous Rocks (10 3/4 Oz.)  
H: 3 3/4" T: 3 1/2"  
B: 3" M: 3 1/2"  
1 Dz.



**G3367**  
Lima Old Fashioned (11 3/4 Oz.)  
H: 3 1/4" T: 2 7/8"  
B: 2 1/8" M: 3 1/2"  
2 Dz.





**P4188**  
Brixton Rocks (10 1/2 Oz.)  
H: 4" T: 3 1/4" M: 3 1/4" B: 2 5/8"  
1 Dz.  
ALSO AVAILABLE IN:  
**NEW P9067** (12 1/2 Oz.)



**N0524** ●●  
Urbane Double Old Fashioned (12 Oz.)  
H: 4 1/8" T: 3 3/4"  
B: 2 3/8" M: 3 3/4"  
1 Dz.  
ALSO AVAILABLE IN:  
**N0531** (9 Oz.)



**D0616**  
Islande Old Fashioned (7 Oz.)  
H: 3 1/4" T: 2 3/4"  
B: 2 5/8" M: 2 3/4"  
4 Dz.  
ALSO AVAILABLE IN:  
**12652** (8 1/2 Oz.)  
**V3469** (10 Oz.)  
**V3476** (12 3/4 Oz.)



**FP321**  
Broadway Double Rocks (12 1/2 Oz.)  
H: 3 3/4" T: 3 5/16"  
M: 3 5/16" B: 2 7/8"  
2 Dz.  
ALSO AVAILABLE IN:  
**NEW FP320** (7 1/2 Oz.)  
**L7254** (10 1/2 Oz.)



**P8500** ●  
Precision Double Old Fashioned (10 1/2 Oz.)  
H: 4" T: 3 1/4"  
B: 3" M: 3 1/4"  
1 Dz.  
ALSO AVAILABLE IN:  
**P8496** (7 1/2 Oz.)  
**P8495** (14 Oz.)



**N5995** ●  
V. Juliette Double Old Fashioned (11 3/4 Oz.)  
H: 3 1/4" T: 3"  
B: 2 1/4" M: 3 3/4"  
2 Dz.



**ARMORIM**  
HIGH RIM RESISTANCE

**ARMORIM**  
HIGH RIM RESISTANCE





**V5794**  
Cabernet Cordial (2 ¼ Oz.)  
H: 5 ¼" T: 1 ¾"  
B: 2" M: 1 ⅞"  
2 Dz.  
Old SKU: E5358



**14798**  
Cabernet Port (4 Oz.)  
H: 5 ⅞" T: 1 ⅝"  
B: 2" M: 2 ⅛"  
2 Dz.



**N8212**  
Cordial (4 Oz.)  
H: 7 ⅞" T: 1 ½"  
B: 2 ⅜" M: 2"  
2 Dz.



**N6374**  
Spirit Taster (6 Oz.)  
H: 5" T: 1 ¾"  
B: 2 ½" M: 3"  
2 Dz.



**N8172**  
Brandy (24 Oz.)  
H: 6 ¾" T: 2 ⅞"  
B: 3 ¼" M: 4 ⅛"  
2 Dz.



**U1032**  
Open Up Warm Tumbler (10 Oz.)  
H: 3 ⅜" T: 2 ⅜"  
B: 1 ⅞" M: 3 ⅞"  
2 Dz.



**42258**  
 Viticole (4 ¼ Oz.)  
 H: 5 ½" T: 1 ⅞"  
 B: 2" M: 2 ½"  
 2 Dz.



**L6119**  
 Kenzie Taster (5 ¾ Oz.)  
 H: 4" T: 2"  
 B: 2 ⅞" M: 2 ⅝"  
 3 Dz.



**71079 •**  
 Excalibur Brandy (12 Oz.)  
 H: 5 ¼" T: 2"  
 B: 2 ⅞" M: 2 ⅜"  
 2 Dz.



**62664**  
 Cabernet Brandy (13 ¾ Oz.)  
 H: 5 ⅞" T: 2 ½"  
 B: 3 ¼" M: 3 ¾"  
 24 Pcs.



# *BEER*



# *The Right Glass For A Crafted Experience*

The number of craft breweries increases each day in the United States. Ensure your customer is having the best experience with their craft drink.

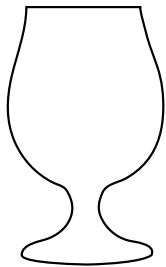

## **STEMWARE**

Lambics  
Saisons  
Upscale Ales  
Lagers

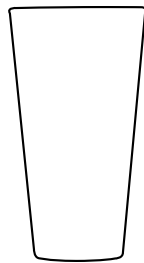

## **GENERAL**

Macro Brews  
All Purpose



## **PUB GLASSES**

IPA  
Pale Ales  
Brown Ales  
Stouts

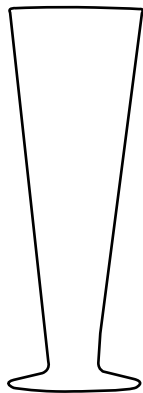

## **PILSNER**

Pilsners  
Pale Lagers

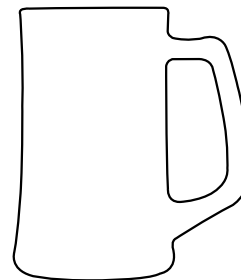

## **MUGS**

Festbiers  
Dark lagers  
Lagers

# Stemware

Tulip shaped stemware elevates the customer experience for high price point occasion beers.



**P0089**  
Sequence Belgian Beer  
(12 ½ Oz.)  
H: 5 7/8" T: 2 ½"  
B: 2 7/8" M: 3 ¼"  
2 Dz.



**N5368**  
Sublym Beer/All Purpose  
(13 Oz.)  
H: 7 ¼" T: 2 ¼"  
B: 3" M: 3 ½"  
2 Dz.



**G3573**  
Cabernet Beer/All Purpose  
(13 ½ Oz.)  
H: 6 9/16" T: 2 7/8"  
B: 3 1/16" M: 3 3/16"  
2 Dz.



**G3570**  
Cabernet Beer/Iced Tea  
(16 Oz.)  
H: 7 7/16" T: 2 5/8"  
B: 3 1/16" M: 3 3/16"  
2 Dz.



**N9711**  
Sequence Beer/Iced Tea  
(16 Oz.)  
H: 7 ¼" T: 2 ¾"  
B: 3" M: 3 3/8"  
2 Dz.



Shown Beer/Iced Tea (16 Oz.)





**FL337\***  
Belgian Beer (13 Oz.)  
H: 5 1/2" T: 2 3/8"  
B: 3" M: 3 1/8"  
2 Dz.



**FL338\***  
Belgian Beer (16 Oz.)  
H: 6" T: 2 7/8"  
B: 3 3/8" M: 3 3/4"  
2 Dz.



**C3544**  
Schooner (18 Oz.)  
H: 7 1/4" T: 4 7/16"  
B: 3 1/2" M: 4 3/4"  
1 Dz.



**07134**  
Cerveise (10 1/2 Oz.)  
H: 6 1/2" T: 2 3/8"  
B: 2 3/16" M: 2 7/8"  
2 Dz.



**V3872**  
Cerveise (12 1/2 Oz.)  
H: 7" T: 2 9/16"  
B: 2 3/4" M: 3"  
2 Dz.



**V3873**  
Cerveise (16 1/2 Oz.)  
H: 7 1/2" T: 2 3/4"  
B: 2 15/16" M: 3 1/4"  
2 Dz.



**P8782 •**  
Romeo All Purpose/ Beer (16 Oz.)  
H: 7" T: 2 7/8"  
B: 3" M: 3 1/4"  
1 Dz.



# General



**J8821**  
Party Mixing Glass (16 Oz.)  
H: 4 7/8" T: 3 3/4"  
B: 2 1/2" M: 3 3/4"  
2 Dz.



**E5458**  
Can Cooler (16 Oz.)  
H: 5 1/4" T: 2 5/8"  
B: 2 1/2" M: 3"  
3 Dz.



**L4865**  
Tall Can Cooler (16 Oz.)  
H: 6 1/2" T: 2 1/4"  
B: 2 1/2" M: 2 5/8"  
2 Dz.



**J4089** ●  
Mixing Glass (14 Oz.)  
H: 5 3/4" T: 3 1/2"  
B: 2 3/8" M: 3 1/2"  
2 Dz.



**H3856** ●●  
Stack Up Beverage (14 Oz.)  
H: 5 1/16" T: 3 1/4"  
B: 2 1/4" M: 3 1/4"  
1 Dz.



**H3089** ●●  
Stack Up Cooler (16 Oz.)  
H: 5 3/4" T: 3 7/16"  
B: 2 3/8" M: 3 7/16"  
1 Dz.



**43100**  
Mixing Glass  
Heavy Sham (14 Oz.)  
H: 5 3/4" T: 3 1/2"  
B: 2 3/8" M: 3 7/16"  
2 Dz.



**J4106** ●  
Mixing Glass (16 Oz.)  
H: 5 3/4" T: 3 1/2"  
B: 2 3/8" M: 3 1/2"  
2 Dz.



**19343** ●  
Mixing Glass (16 Oz.)  
H: 5 3/4" T: 3 1/2"  
B: 2 3/8" M: 3 1/2"  
2 Dz.



**G3960**  
Mixing Glass (16 Oz.)  
H: 5 3/4" T: 3 1/2"  
B: 2 3/8" M: 3 1/2"  
2 Dz.



**44273**  
Mixing Glass  
Heavy Sham (18 Oz.)  
H: 6 3/4" T: 3 1/16"  
B: 2 3/8" M: 3 1/16"  
2 Dz.



**22032** ●  
Mixing Glass (20 1/2 Oz.)  
H: 6 3/4" T: 3 5/8"  
B: 2 3/8" M: 3 5/8"  
2 Dz.



**L8970** ●  
Mixing Glass (22 Oz.)  
H: 7" T: 3 5/8"  
B: 2 1/2" M: 3 5/8"  
2 Dz.





Shown Nonic Tumbler (10 Oz.)

# Pub Glasses

ARCOROC

Best for IPAs, Pale Ales, Brown Ales, and Stouts features a wide mouth to support the frothy head of traditional ales.



**43716** ●●  
Nonic Tumbler (10 Oz.)  
H: 4 ½" T: 2 ⅞"  
B: 2 ⅞" M: 2 ⅞"  
4 Dz.



**E8792** ●●●  
Nonic Tumbler (16 Oz.)  
H: 5 ⅝" T: 3 ⅞"  
B: 2 ½" M: 3 ⅞"  
4 Dz.



**V3471** ●●  
Nonic Tumbler (20 Oz.)  
H: 5 ⅞" T: 3 ⅞"  
B: 2 ⅝" M: 3 ⅞"  
2 Dz.



**V7445**  
Willi Tumbler (13 ½ Oz.)  
H: 5 ⅞" T: 2 ⅝"  
B: 2" M: 2 ⅝"  
1 Dz.



**C5872**  
Willi Tumbler (16 Oz.)  
H: 6 ⅜" T: 2 ⅞"  
B: 2 ¼" M: 3 ⅞"  
1 Dz.



**J0825** ●●  
Tulip Tumbler (16 Oz.)  
H: 5 ¾" T: 3 ⅞"  
B: 2 ½" M: 3 ⅞"  
2 Dz.



**52643** ●●●  
Tulip Tumbler (16 Oz.)  
H: 5 ¾" T: 3 ⅞"  
B: 2 ½" M: 3 ⅞"  
2 Dz.



**P3008** ●●  
Tulip Tumbler (20 Oz.)  
H: 6 ⅜" T: 3 ⅞"  
B: 2 ⅝" M: 3 ⅞"  
2 Dz.



## *Pilsners*

The Pilsner glass showcases the beer's color, clarity and carbonation. The conical shape helps maintain the beer's head and allows aromas to reach your nose.



**N2644**  
Classic Pilsner (14 Oz.)  
H: 9" T: 3 1/8"  
B: 3 1/4" M: 3 1/4"  
1 Dz.



**D0129**  
Occasion Pilsner (15 Oz.)  
H: 8 3/8" T: 2 5/8"  
B: 2 7/8" M: 2 7/8"  
2 Dz.



**04900**  
Martigues (16 Oz.)  
H: 8 3/8" T: 3 1/4"  
B: 2 1/2" M: 3 1/4"  
2 Dz.



**25263**  
Linz (13 ½ Oz.)  
H: 8 ½" T: 2 ¾"  
B: 2 1/16" M: 2 ¾"  
2 Dz.



**H9211**  
Linz (18 ½ Oz.)  
H: 7 ½" T: 3 ½"  
B: 3 ¼" M: 3 ¼"  
2 Dz.



**25275**  
Linz (23 Oz.)  
H: 8 ½" T: 3 5/16"  
B: 3 ¼" M: 3 5/16"  
2 Dz.



**21053**  
Grand Pilsner (16 Oz.)  
H: 8 3/8" T: 2 7/8"  
B: 2 ½" M: 2 7/8"  
3 Dz.



**19416**  
Grand Pilsner (20 Oz.)  
H: 8 7/16" T: 3 ¼"  
B: 2 ¾" M: 3 ¼"  
2 Dz.



**19415**  
Grand Pilsner (23 Oz.)  
H: 9" T: 3 ¼"  
B: 2 ¾" M: 3 ¼"  
2 Dz.



**36229**  
Pub Pilsner (23 Oz.)  
H: 9" T: 3 ½"  
B: 2 7/8" M: 3 3/8"  
2 Dz.



**E6141** ●  
Outdoor Perfect Pilsner (23 Oz.)  
H: 10" T: 3 ¼"  
B: 2 7/8" M: 3 ¼"  
3 Dz.



# Mugs



**C0790**  
Dayton Mug (22 Oz.)  
H: 8 5/8" T: 3"  
B: 3 3/8" M: 3 3/8"  
1 Dz.



**53404**  
Sport Mug (25 Oz.)  
H: 6 3/8" T: 3 3/8"  
B: 4" M: 6"  
1 Dz.



**C1643**  
Mug (10 Oz.)  
H: 5 7/8" T: 2 7/8"  
B: 3 1/4" M: 4 7/8"  
1 Dz.

# Samplers



Shown Kenzie Taster (5 3/4 Oz.), Hollow Beer Paddle



**D2443**  
Bell Taster (7 1/4 Oz.)  
H: 4" T: 2 1/2"  
B: 1 7/8" M: 2 5/8"  
6 Dz.



**L6119**  
Kenzie Taster (5 3/4 Oz.)  
H: 4" T: 2"  
B: 2 1/8" M: 2 5/8"  
3 Dz.



**FK856\***  
Hollow Beer Paddle  
16" x 3 1/4" Hole Dimension: 2"  
1 Dz.

\*Hand Wash ONLY

Glassware Recommendations:  
D2443, L6119, N0529, J4238, J4094

# Room Tumblers

With a simple and functional design, the in-room tumbler is suitable for a variety of beverages, including water, juice, or other non-alcoholic drinks.



Shown Broadway Rocks (10 1/2 Oz.)



**43746**  
Room Tumbler (8 Oz.)  
H: 3 5/8" T: 2 3/4"  
B: 2 5/8" M: 2 3/4"  
6 Dz.



**29811**  
Room Tumbler (8 3/4 Oz.)  
H: 3 5/8" T: 3"  
B: 2 3/4" M: 3"  
3 Dz.



**E1908 •**  
Petale Hi Ball (8 3/4 Oz.)  
H: 4 1/6" T: 3"  
B: 2" M: 3"  
4 Dz.



**L7254**  
Broadway Rocks (10 1/2 Oz.)  
H: 3 1/2" T: 3 3/8"  
B: 3" M: 3 3/8"  
2 Dz.



**76495**  
Sterling Rocks (9 3/4 Oz.)  
H: 3 5/8" T: 3 3/8"  
B: 3 1/8" M: 3 3/8"  
3 Dz.

ALSO AVAILABLE IN:  
**NEW FP320** (7 1/2 Oz.)



**V8953**  
Imperator Old Fashioned  
(10 1/4 Oz.)  
H: 3 5/8" T: 3 1/4"  
M: 3 1/4" B: 2 1/2"  
2 Dz.



**V8954**  
Elysees Old Fashioned  
(10 1/2 Oz.)  
H: 3 5/8" T: 3 1/8"  
M: 3 1/8" B: 2 3/4"  
2 Dz.



**V8956**  
Quadrille Old Fashioned  
(12 1/4 Oz.)  
H: 3 1/2" T: 3 1/4"  
M: 3 1/4" B: 2 5/8"  
2 Dz.



**43745**  
Room Tumbler (11 Oz.)  
H: 3 1/2" T: 3 1/8"  
B: 3" M: 3 1/8"  
3 Dz.



## *Decanters & Carafes*

A decanter is an elegant vessel that exposes the wine to oxygen, allowing it to breathe and develop its flavors and aromas before being served.



**D6653**  
Open Up Decanter (47 ¼ Oz.)  
H: 12 ⅝" M: 5 ¾"  
2 Pcs.



**R0020**  
Opening Decanter (30 ¼ Oz.)  
H: 9 ⅜" M: 8 ⅜"  
2 Pcs.



**V0410**  
Millesime Carafe,  
Magnum (67 ½ Oz. - 2 L)  
H: 9 ½" T: 2 ⅜"  
B: 4 ¼" M: 8 ¼"  
2 Pcs.





**FL470**  
Carafe (10 Oz.)  
H: 4 3/4" T: 2 5/8"  
B: 3" M: 3"  
2 Dz.  
APPROXIMATE POUR LINE



**D1C08365**  
Wave Carafe (8 1/4 Oz.)  
(with blue wave pour line)  
H: 5 1/4" T: 2 1/4"  
B: 2 1/4" M: 3 1/8"  
1 Dz.  
APPROXIMATE POUR LINE

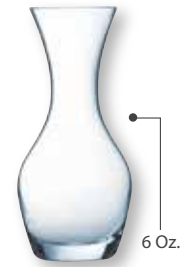

**FE644\***  
By the Glass Carafe  
H: 6" T: 2"  
B: 1 7/8" M: 2 3/4"  
2 Dz.  
\*DUE TO THE NATURE OF THE MOUTHBLOWN DESIGN CAPACITIES MAY VARY UP TO 0.5 OZ.



**C0198**  
Carafe (8 1/4 Oz. - 1/4 L)  
H: 5 1/4" T: 2 1/4"  
B: 2 1/4" M: 3 1/8"  
1 Dz.



**33040**  
Carafe (17 Oz. - 1/2 L)  
H: 6 1/2" T: 2 3/16"  
B: 2 3/4" M: 3 7/8"  
1 Dz.



**53673**  
Carafe (17 Oz. - 1/2 L)  
H: 7 3/4" T: 1 5/8"  
B: 3 1/8" M: 3 1/8"  
1 Dz.



**53675**  
Carafe (33 3/4 Oz. - 1L)  
H: 10" T: 2 1/8"  
B: 3 3/4" M: 3 3/4"  
6 Pcs.



**10291**  
Carafe (33 3/4 Oz. - 1L)  
H: 8" T: 3"  
B: 3 7/16" M: 4 5/8"  
6 Pcs.



**FP331**  
Bystro Grand Carafe (33 3/4 Oz. - 1L)  
H: 10 3/4" T: 3 1/4"  
M: 3 5/8" B: 3 1/2"  
1 Dz.

# Fluid Carafes

Capacity measurements are to the neck.



**L4212**  
Fluid Carafe (8 1/4 Oz.)  
H: 5 1/4" M: 2 3/4"  
1 Dz.



**L3963**  
Fluid Carafe (16 3/4 Oz.)  
H: 7 1/2" M: 3 1/2"  
6 Pcs.



**Q4033\***  
Fluid Carafe Frost Blue (25 1/4 Oz.)  
H: 8 1/4" M: 3 5/8"  
6 Pcs.



**Q4025\***  
Fluid Carafe Frost Green (25 1/4 Oz.)  
H: 8 1/4" M: 3 5/8"  
6 Pcs.



**Q4026\***  
Fluid Carafe Frost (25 1/4 Oz.)  
H: 8 1/4" M: 3 5/8"  
6 Pcs.



**L6247**  
Fluid Carafe (25 1/4 Oz.)  
H: 8 1/4" M: 3 5/8"  
6 Pcs.



**L3965**  
Fluid Carafe (33 3/4 Oz.)  
H: 10 3/8" M: 4 1/8"  
6 Pcs.



**L4194**  
Fluid Carafe W/ Stopper (16 3/4 Oz.)  
H: 7 1/2" M: 3 1/2"  
6 Pcs.



**L4193**  
Fluid Carafe W/ Stopper (33 3/4 Oz.)  
H: 10 3/8" M: 4 1/8"  
6 Pcs.



**L4257**  
Black Stopper  
H: 1 1/2" M: 2 3/4"  
2 Dz.  
FITS: L6247, Q4033, Q4025,  
Q4026 and L4194



# Pitchers



**E7255**  
Pitcher with Pour Lip (34 Oz.)  
H: 8" T: 3 7/8"  
B: 3 3/8" M: 5 3/4"  
6 Pcs.



**G3478**  
Pitcher with Pour Lip (16 Oz.)  
H: 5 3/4" T: 3 7/8"  
B: 3 3/8" M: 5"  
12 Pcs.



**E7254**  
Pitcher with Pour Lip (44 Oz.)  
H: 8 1/2" T: 4"  
B: 4" M: 8 3/8"  
6 Pcs.



**C0678**  
Pitcher with Pour Lip (60 Oz.)  
H: 9" T: 5 3/4"  
B: 4 1/2" M: 8 1/4"  
6 Pcs.



**E9298** ●  
Outdoor Perfect Pitcher  
with Pour Lip (67 1/2 Oz.)  
H: 10 1/4" T: 9"  
B: 3 1/4" M: 9"  
1 Dz.

# Swing Top Bottle

ARCOROC



**FJ014**  
Swing Top Bottle (8 ½ Oz.)  
H: 7 ¾" T: 1 ½"  
B: 2 ½" M: 2 ½"  
2 Dz.



**FJ015**  
Swing Top Bottle (17 Oz.)  
H: 10" T: 1 ½"  
B: 2 ½" M: 2 ¾"  
1 Dz.



**FJ016**  
Swing Top Bottle (25 ¼ Oz.)  
H: 11 ¼" T: 1 ½"  
B: 3" M: 3 ¼"  
6 Pcs.

# Mix

The Mix Collection, designed by world renowned mixologist, Chris Adams, was made to withstand the rigor of high volume restaurants and bars, while still focusing on the craft.



**FP198**  
Ellis Adams Jigger  
Bronze Copper  
H: 3 1/4" T: 2"  
B: 1 3/4" M: 2"  
1 Pc.



**MT051**  
Ellis Adams Jigger  
Black Matte  
H: 3 1/4" T: 2"  
B: 1 3/4" M: 2"  
1 Pc.



**CAP32**  
Stainless Jigger  
H: 3 1/4" T: 2"  
B: 1 3/4" M: 2"  
1 Pc.  
\*Inner Oz. indicators



**CAP51**  
Tall Stainless Jigger  
H: 5 1/8" T: 2"  
B: 1 7/8" M: 2"  
1 Pc.  
\*Inner Oz. indicators



**OL167**  
Bitters Bottle/  
Dasher Top (5 Oz.)  
H: 4 3/8" T: 1 1/16"  
B: 2 3/8" M: 2 3/8"  
2 Dz.



**FP332**  
Broadway Beaker (24 Oz.)  
H: 6" T: 4 3/8"  
M: 4 3/8" B: 3 5/8"  
6 Pcs.



**FK596**  
Mixing Beaker (20 Oz.)  
H: 6 1/4" T: 3 1/2"  
B: 3 1/2" M: 3 1/2"  
8 Pcs.



**FP190**  
Bronze Copper Shaker Tin (28 Oz.)  
H: 7" T: 3 5/8"  
B: 2 3/8" M: 3 5/8"  
1 Pc.



**CAP28**  
Shaker Tin (28 Oz.)  
H: 7" T: 3 5/8"  
B: 2 3/8" M: 3 5/8"  
1 Pc.



**MT849**  
Black Matte Shaker Tin (28 Oz.)  
H: 7" T: 3 5/8"  
B: 2 3/8" M: 3 5/8"  
1 Pc.



**CAP18**  
Shaker Tin (18 Oz.)  
H: 5 1/4" T: 3 7/16"  
B: 2 3/8" M: 3 7/16"  
1 Pc.



**FP188**  
Bronze Copper Shaker Tin (20 Oz.)  
H: 5 1/4" T: 3 7/16"  
B: 2 3/8" M: 3 7/16"  
1 Pc.



**CAP20**  
Shaker Tin (20 Oz.)  
H: 5 1/2" T: 3 1/2"  
B: 2 3/8" M: 3 1/2"  
1 Pc.



**MT850**  
Black Matte Shaker Tin (20 Oz.)  
H: 5 1/2" T: 3 1/2"  
B: 2 3/8" M: 3 1/2"  
1 Pc.



**CAP05**  
Dual Sided Paddle  
Bar Spoon  
L: 15 3/4"  
1 Pc.



**MT011**  
Dual Sided Teardrop  
Bar Spoon Black Matte  
L: 15 3/4"  
1 Pc.



NEW

**FP197**  
Dual Sided Teardrop Bar  
Spoon Bronze Copper  
L: 15 3/4"  
1 Pc.



**CAP04**  
Fine Mesh Strainer  
L: 8 3/4" W: 3 1/8"  
1 Pc.



**MT004**  
Fine Mesh Strainer Black Matte  
L: 8 3/4" W: 3 1/8"  
1 Pc.



NEW

**FP193**  
Fine Mesh Strainer Bronze Copper  
L: 8 3/4" W: 3 1/8"  
1 Pc.



**HS001**  
Hawthorne Strainer Stainless  
L: 6 1/4" W: 3 3/8"  
1 Pc.



**HS002**  
Hawthorne Strainer  
Black Matte  
L: 6 1/4" W: 3 3/8"  
1 Pc.



NEW

**FP196**  
Hawthorne Strainer  
Bronze Copper  
L: 6 1/4" W: 3 3/8"  
1 Pc.





**CAP02**  
Julep Strainer  
L: 7 1/6" W: 3"  
1 Pc.



**MT002**  
Julep Strainer Black Matte  
L: 7 1/6" W: 3"  
1 Pc.

NEW



**FP195**  
Julep Strainer Bronze Copper  
L: 7 1/6" W: 3"  
1 Pc.



**CAP07**  
Ellis Bar Knife  
L: 8 15/16"  
1 Pc.



**CAP01**  
Tweezers  
L: 6 1/4"  
1 Pc.



**CAP09**  
Muddler  
L: 9 1/2"  
1 Pc.



**OL166**  
Juice Bottle (16 Oz.)  
H: 10 1/8" T: 1 1/8"  
B: 2 3/8" M: 2 3/8"  
6 Pcs.



Silicone Bands 1/2"  
6 Pcs.  
(Colors Sold Separately)

- RBP04** Purple
- RBB02** Blue
- RBV03** Yellow
- RBDG3** Green
- RBW06** White
- RBR09** Red
- RBB06** Black
- RBBR7** Brown





# *OUTDOOR PERFECT*

Made from fully recyclable, BPA-Free S.A.N. plastic.  
Tests have shown no deterioration in the material  
up to 2,000 cycles in an industrial dishwasher.  
In addition, pieces feature water vents on the  
bottom to allow proper drainage.

**For Cold Beverages ONLY**

# Outdoor Perfect



**E6125**  
Flute (5 ½ Oz.)  
H: 8 ½" T: 2"  
B: 2 ¾" M: 2 ¼"  
3 Dz.



**E6131**  
Wine (10 Oz.)  
H: 7 ¾" T: 2 7/8"  
B: 3" M: 3"  
3 Dz.



**FM120**  
Stemless Wine (15 Oz.)  
H: 4 ¾" T: 2 ½"  
B: 1 7/8" M: 3 ¾"  
3 Dz.



**E6134**  
Rocks (10 Oz.)  
H: 4 ½" T: 3 ¼"  
B: 2" M: 3 ¼"  
3 Dz.



**E6137**  
Double Old Fashioned (14 ¾ Oz.)  
H: 4 ½" T: 3 ¾"  
B: 2 5/8" M: 3 ¾"  
3 Dz.



**E6136**  
Hi Ball (12 ¾ Oz.)  
H: 6 ¼" T: 3"  
B: 1 7/8" M: 3 ¼"  
3 Dz.

**E6138**  
Hi Ball (16 Oz.)  
H: 7" T: 3 ½"  
B: 2 ½" M: 3 ½"  
3 Dz.



**FM077**  
Cooler (19 ¾ Oz.)  
H: 6 ¾" T: 3 ¾"  
B: 2 ¾" M: 3 ¾"  
3 Dz.



**E6141**  
Pilsner (23 Oz.)  
H: 10" T: 3 ¼"  
B: 2 7/8" M: 3 ¼"  
3 Dz.

Shown Flute (3 1/2 Oz.), Margarita (12 Oz.), Double Old Fashioned (14 3/4 Oz.)



**E6133**  
Rocks (3 Oz.)  
H: 3 5/8" T: 2 1/8"  
B: 1 1/8" M: 2"  
3 Dz.



**E6132**  
Cocktail (10 Oz.)  
H: 7 3/8" T: 4 3/4"  
B: 3 1/4" M: 4 5/8"  
2 Dz.



**E6127**  
Margarita (12 Oz.)  
H: 6 7/8" T: 4 7/8"  
B: 3 1/4" M: 4 3/4"  
2 Dz.



**E6128**  
Hurricane (14 3/4 Oz.)  
H: 9 1/8" T: 2 7/8"  
B: 3" M: 2 7/8"  
3 Dz.



**E9298**  
Pitcher (67 1/2 Oz.)  
H: 10 1/4" T: 9"  
B: 3 1/4" M: 9"  
1 Dz.

Shown Blue Cooler (19 ¾ Oz.), Blue Hi Ball (16 Oz.)



**FM400**  
Blue Rocks (10 Oz.)  
H: 4 ½" T: 3 ¼"  
B: 2" M: 3 ¼"  
3 Dz.



**ODP36**  
Blue Hi Ball (12 ¾ Oz.)  
H: 6 ¼" T: 3"  
B: 1 ⅞" M: 3 ¼"  
3 Dz.



**FM403**  
Blue Cooler (19 ¾ Oz.)  
H: 6 ⅝" T: 3 ¾"  
B: 2 ⅜" M: 3 ¾"  
3 Dz.

# Outdoor Perfect *cont'd.*

ARCOROC



**FN090**  
Rocks (10 ½ Oz.)  
H: 3 ¾" T: 3 ¾"  
B: 2 ½" M: 3 ⅝"  
3 Dz.



**FN091**  
Double Old Fashioned (12 Oz.)  
H: 3 ¾" T: 3 ¾"  
B: 2 1¼" M: 3 ⅝"  
3 Dz.



**FN092**  
Beverage (14 Oz.)  
H: 5 1¼" T: 3 ¼"  
B: 2 ¼" M: 3 ¼"  
3 Dz.



**FN093**  
Cooler (16 Oz.)  
H: 5 ¾" T: 3 ⅞"  
B: 2 ¾" M: 3 ⅞"  
3 Dz.



Shown Rocks (10 ½ Oz.), Double Old Fashioned (12 Oz.), Cooler (16 Oz.)





Shown Harvest Collection





*Dinnerware*





Industrial Toughness and Craftsmanship  
for the Hospitality Market.

Over 200 Years of Heritage: Renowned craft potters, the prestigious Dudson brand carries a rich heritage dating back to 1800. Craftsmanship, accompanied by authentic and inspiring designs, have been at the heart of developing the brand into a globally recognized symbol of stylish food presentation.



**Vitrified Ceramic** – Fully vitrified ceramic bodies creates a "closed" structure and the result of this is a very strong and durable product.

The Maker's Collection: Finca	164
The Maker's Collection: Jute Grey <i>NEW</i>	166
The Maker's Collection: Porto Blue <i>NEW</i>	168
The Maker's Collection: Urban	170
Evo Origins	172
Harvest	174
Harvest Mediterranean Moresque <i>NEW</i>	178
Harvest Norse <i>NEW</i>	180
Harvest Norse White <i>NEW</i>	182
Organic White	184

## Vitrified Stoneware

**Vitrified Stoneware** – Ceramic made from clay and fired at high temperature combining artisanal design with industrial strength.

Evo Azure <i>NEW</i>	186
Evo	188

## Wood

Acacia Wood	191
-------------	-----



Made In England – Using the Dudson Finest Vitrified ceramic body.



Individuality Through Print – Printing creates individuality within each piece, as the light and dark color tones vary. Reactive prints create an individual texture and colors.



Handcrafted Collection – Each piece is individually glazed by hand leaving an original 'maker's mark', on the reverse, highlighting the hand crafted nature.



Fully Glazed Foot – Pin firing. Fully glazed foot prevents scratching and cross contamination when product is stacked. All England made products come with a fully glazed foot.

THE  
**maker's**  
COLLECTION

## *Finca*

Finca is a multi-tonal print that mimics the worn textures of rustic interiors and architectural designs. Crafted and creative, Finca is finished in a semi-matte, hand dipped glaze, enhancing the character of the collection and leaving original 'makers marks' on the reverse of each piece.

Decorated in-glaze for industrial toughness, The Maker's Collection is designed for professional use.

Sandstone



Limestone





Narrow Rim Plate 6" ★  
1 Dz.

**FN526** Sandstone  
**FN502** Limestone

Narrow Rim Plate 8" ★  
1 Dz.

**FN525** Sandstone  
**FN501** Limestone

Narrow Rim Plate 9" ★  
1 Dz.

**FN524** Sandstone  
**FN500** Limestone



Narrow Rim Plate 10" ★  
1 Dz.

**FN523** Sandstone  
**FN499** Limestone

Narrow Rim Plate 11" ★  
1 Dz.

**FN522** Sandstone  
**FN498** Limestone



Organic Coupe Plate 9" ★  
1 Dz.

**FN518** Sandstone  
**FN494** Limestone

Organic Coupe Plate 10 3/4" ★  
1 Dz.

**FN517** Sandstone  
**FN493** Limestone



Organic Coupe Bowl 9 3/4" (28 Oz.) ★  
1 Dz.

**FN519** Sandstone  
**FN495** Limestone



Narrow Rim Bowl 8 1/4" (16 Oz.) ★  
1 Dz.

**FN527** Sandstone  
**FN503** Limestone



Organic Rectangular Plate  
10 5/8" x 6 1/4"  
1 Dz.

**FN520** Sandstone  
**FN496** Limestone



Organic Rectangular Plate  
13 5/8" x 6 1/4"  
6 Pc.

**FN521** Sandstone  
**FN497** Limestone



Cappuccino Cup (12 Oz.) ★  
T: 4 1/4" M: 5 1/2" H: 2 3/4"  
1 Dz.

**FN528** Sandstone  
**FN504** Limestone



Coffee/Tea Cup (8 Oz.) ★  
T: 3 3/4" M: 4 3/4" H: 2 1/4"  
1 Dz.

**FN529** Sandstone  
**FN505** Limestone



Saucer 6 1/4" ★  
1 Dz.

**FN530** Sandstone  
**FN506** Limestone  
(Fits FN504, FN505,  
FN528, FN529)



Espresso Cup (3 1/2 Oz.) ★  
T: 2 1/2" M: 3 3/8" H: 2 1/4"  
1 Dz.

**FN531** Sandstone  
**FN507** Limestone



Espresso Saucer 4 1/2" ★  
1 Dz.

**FN532** Sandstone  
**FN508** Limestone  
(Fits FN531, FN507)



THE  
**maker's**  
COLLECTION

*Jute Grey* **NEW**

The Maker's Collection Jute is inspired by the crafted technique of hand-weaving natural fabrics featured within today's interior decor. The design mimics the organic and detailed texture of Jute material, first crafted in India from sustainable plant fibre.





**FP194 ★**  
Organic Coupe Plate 9"  
1 Dz.



**FP200 ★**  
Organic Coupe Plate 10 3/4"  
1 Dz.



**FP192 ★**  
Organic Coupe Plate 11 1/4"  
1 Dz.



**FP201 ★**  
Organic Bowl 9 3/4" (28 Oz.)  
1 Dz.



**FP199 ★**  
Organic Bowl 11" (47 1/2 Oz.)  
1 Dz.



**FP202**  
Rectangular Plate  
10 5/8" x 6 1/4"  
1 Dz.



**FP203**  
Rectangular Plate  
13 5/8" x 6 1/4"  
6 Pc.

THE  
**maker's**  
COLLECTION

*Porto Blue* **NEW**

The Maker's Collection Porto is inspired by the historical, hand-painted tiles featured within Portuguese architecture. Distinctive and decorative, Porto resembles a mosaic design, capturing the essence of hand-crafted and artisan Portuguese azulejos.







**FP174 ★**  
Coupe Plate 6 1/2"  
1 Dz.



**FP173 ★**  
Coupe Plate 8 2/3"  
1 Dz.



**FP172 ★**  
Coupe Plate 10 1/4"  
1 Dz.



**FP171 ★**  
Coupe Plate 11 1/4"  
1 Dz.



**FP176 ★**  
Coupe Bowl 7 1/4" (15 Oz.)  
1 Dz.



**FP175 ★**  
Coupe Bowl 9 3/4" (40 Oz.)  
1 Dz.



**FP177**  
Rectangular Plate  
10 5/8" x 6 1/4"  
1 Dz.



**FP178**  
Rectangular Plate  
13 5/8" x 6 1/4"  
6 Pc.

THE  
**maker's**  
COLLECTION

## *Urban*

The Maker's Collection Urban features a burnished effect inspired by the industrial history of UK made ceramics. Urban mimics the worn, man-made textures of industrial landscapes. Decorated under a semi-matte glaze for toughness, Urban is designed for professional use. Available in Steel Grey and Lamp Black, the Urban color palette reflects the raw luxury of contemporary interior design.

Lamp Black

Steel Grey





Narrow Rim Plate 6" ★  
1 Dz.

**FN555** Lamp Black  
**FN462** Steel Grey



Narrow Rim Plate 7" ★  
1 Dz.

**FN553** Lamp Black  
**FN461** Steel Grey



Narrow Rim Plate 8" ★  
1 Dz.

**FN552** Lamp Black  
**FN460** Steel Grey



Narrow Rim Plate 9" ★  
1 Dz.

**FN551** Lamp Black  
**FN459** Steel Grey



Narrow Rim Plate 10" ★  
1 Dz.

**FN550** Lamp Black  
**FN458** Steel Grey



Narrow Rim Plate 11" ★  
1 Dz.

**FN549** Lamp Black  
**FN457** Steel Grey



Deep Coupe Plate 10" ★  
1 Dz.

**FN560** Lamp Black  
**FN466** Steel Grey



Deep Coupe Plate 11" ★  
1 Dz.

**FN559** Lamp Black  
**FN465** Steel Grey



Coupe Bowl 7 ¼" (15 Oz.) ★  
1 Dz.

**FN557** Lamp Black  
**FN464** Steel Grey



Coupe Bowl 9 ¾" (40 Oz.) ★  
1 Dz.

**FN556** Lamp Black  
**FN463** Steel Grey



Organic Rectangular Plate  
10 ⅝" x 6 ¼"  
1 Dz.

**FN561** Lamp Black  
**FN467** Steel Grey



Organic Rectangular Plate  
13 ⅝" x 6 ¼"  
6 Pcs.

**FN562** Lamp Black  
**FN468** Steel Grey

# *Evo Origins*

Evo Origins has the look of real stone. Its textured semi matte finish will add a new layer of plating possibilities.

Mix it with Evo Pearl, Jet or Granite for a striking look.

Natural  
Grey



Black





Coupe Plate 6 1/2" ★  
1 Dz.

**EO165** Natural Grey  
**EB165** Black



Coupe Plate 8 3/8" ★  
1 Dz.

**EO217** Natural Grey  
**EB217** Black



Coupe Plate 10 1/4" ★  
1 Dz.

**EO260** Natural Grey  
**EB260** Black



Coupe Plate 11 1/4" ★  
1 Dz.

**EO288** Natural Grey  
**EB288** Black



Coupe Bowl 7 1/4" (15 Oz.) ★  
1 Dz.

**EO182** Natural Grey  
**EB182** Black



Coupe Bowl 9 3/4" (40 Oz.) ★  
1 Dz.

**EO248** Natural Grey  
**EB248** Black



Deep Coupe Plate 10" ★  
1 Dz.

**EO255** Natural Grey  
**EB255** Black



Deep Coupe Plate 11" ★  
1 Dz.

**EO281** Natural Grey  
**EB281** Black



Chefs' Oblong Plate  
11 3/4" x 6"  
1 Dz.

**EO298** Natural Grey  
**EB298** Black



Chefs' Oblong Plate  
13 7/8" x 7 3/8"  
6 Pcs.

**EO355** Natural Grey

# Harvest

A handcrafted collection; each piece is individually glazed and features a hand finished sponge rim. Made in England and designed with industrial toughness.

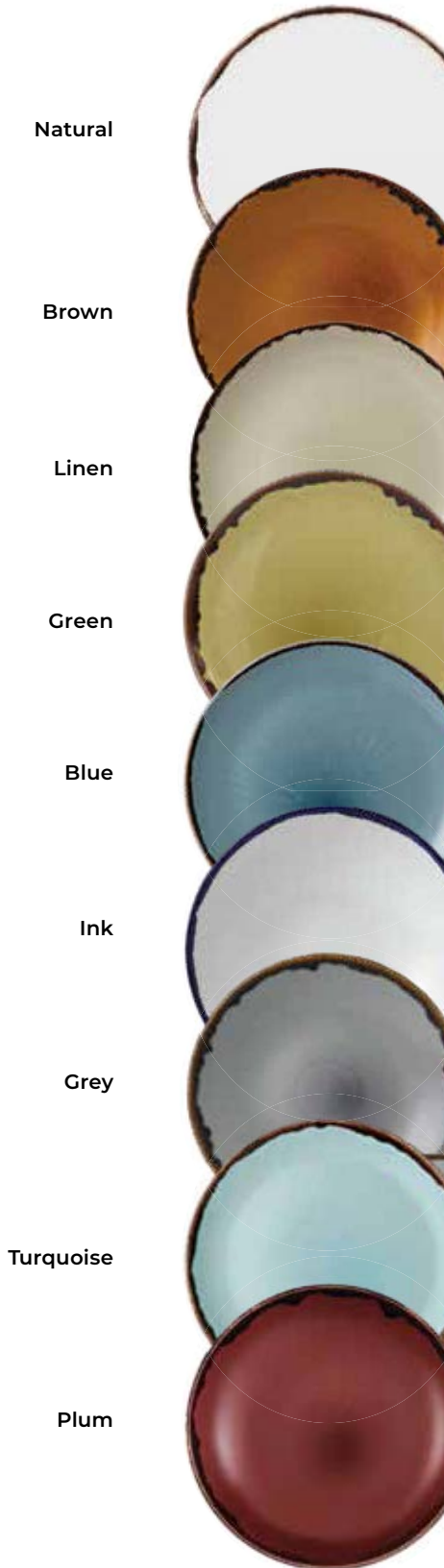



Coupe Plate 6 1/2" ★  
1 Dz.

**HN165** Natural  
**HB165** Brown  
**HL165** Linen  
**HG165** Green  
**HBL16** Blue  
**HI650** Ink  
**HG650** Grey  
**FN932** Turquoise  
**FP088** Plum



Coupe Plate 8 3/8" ★  
1 Dz.

**HN217** Natural  
**HB217** Brown  
**HL217** Linen  
**HG217** Green  
**HBL21** Blue  
**HI867** Ink  
**HG867** Grey  
**FN935** Turquoise  
**FP087** Plum



Coupe Plate 10 1/4" ★  
1 Dz.

**HN260** Natural  
**HB260** Brown  
**HL260** Linen  
**HG260** Green  
**HBL26** Blue  
**HI102** Ink  
**HG102** Grey  
**FN930** Turquoise  
**FP086** Plum



Coupe Plate 11 1/4" ★  
1 Dz.

**HN288** Natural  
**HB288** Brown  
**HL288** Linen  
**HG288** Green  
**HBL28** Blue  
**HI111** Ink  
**HG112** Grey  
**FN931** Turquoise  
**FP085** Plum



Flat Plate 12 1/2"  
6 Pcs.

**HN317** Natural



Coupe Plate 12 3/4" ★  
6 Pcs.

**HG324** Green  
**HB324** Blue



Deep Coupe Plate 10" ★  
1 Dz.

**HN255** Natural  
**HB255** Brown  
**HL255** Linen  
**HG255** Green  
**HBL25** Blue  
**HID10** Ink  
**HGD10** Grey



Deep Coupe Plate 11" ★  
1 Dz.

**HN281** Natural  
**HB281** Brown  
**HL281** Linen  
**HG281** Green  
**HBL11** Blue  
**HID11** Ink  
**HGD11** Grey



Coupe Bowl 7 1/4" (15 Oz.) ★  
1 Dz.

**HN182** Natural  
**HB182** Brown  
**HL182** Linen  
**HG182** Green  
**HBL18** Blue  
**HI725** Ink  
**HG725** Grey  
**FN928** Turquoise  
**FP090** Plum



Coupe Bowl 9 3/4" (40 Oz.) ★  
1 Dz.

**HN248** Natural  
**HB248** Brown  
**HL248** Linen  
**HG248** Green  
**HBL24** Blue  
**HI975** Ink  
**HG975** Grey  
**FN929** Turquoise  
**FP089** Plum



Organic Bowl 11 3/8" (52 7/10 Oz.)  
6 Pcs.

**HN113** Natural



Trace Organic Bowl 9 7/8" (38 Oz.)  
1 Dz.

**HN253** Natural  
**HB253** Brown  
**HL253** Linen  
**HG253** Green  
**HBL38** Blue  
**HI978** Ink  
**HG978** Grey





Shown Walled Plate 8 ¼" Ink



Organic Coupe Bowl 8 1/8" (15 Oz.)  
1 Dz.

**FN941** Turquoise



Organic Coupe Bowl 9 3/4" (28 Oz.)  
1 Dz.

**FN942** Turquoise



Organic Coupe Bowl 11" (47 1/2 Oz.)  
1 Dz.

**FN940** Turquoise



Walled Plate 8 ¼"  
6 Pcs.

**HNW86** Natural  
**HB867** Blue  
**FP111** Ink



Walled Plate 10 ¼"  
6 Pcs.

**HNW10** Natural  
**HB102** Blue  
**FP112** Ink



Deep Bowl (16 1/2 Oz.)  
6 7/8" x 5 3/4"  
6 Pcs.

**HND63** Natural  
**HB634** Blue



Deep Bowl (18 Oz.)  
7 7/8" x 6 5/8"  
6 Pcs.

**HND77** Natural  
**HB778** Blue



Sauce Dish (3 Oz.)  
3 1/4" x 1 3/4"  
1 Dz.

**FM740** Natural  
**FN827** Ink **NEW**



Sugar Bowl/Bouillon (8 Oz.) ★  
3 7/8" x 2 1/2"  
1 Dz.

**FM741** Natural  
**FN828** Ink **NEW**  
(Fits: FM736, HI156, FP617)





Organic Rectangular Plate  
10 5/8" x 6 1/4"  
1 Dz.

**FN943** Turquoise  
**FP091** Plum



Chef's Oblong Plate  
11 3/4" x 6"  
1 Dz.

**HN298** Natural  
**HB298** Brown  
**HL298** Linen  
**HG298** Green  
**HBL29** Blue  
**HIC11** Ink  
**HGC11** Grey



Chef's Oblong Plate  
13 7/8" x 7 3/8"  
6 Pcs.

**HN355** Natural  
**HB355** Brown  
**HL355** Linen  
**HG355** Green  
**HBL35** Blue  
**HIC13** Ink  
**HGC13** Grey



Small Rectangular Tray  
11 1/4" x 7 1/2"  
6 Pcs.

**HN001** Natural  
**HB001** Brown  
**HL001** Linen  
**HG001** Green  
**HBL00** Blue  
**HIR11** Ink  
**HGR11** Grey



Organic Coupe Rectangular Platter  
13 5/8" x 6 1/4"  
6 Pcs.

**FN946** Turquoise  
**FP092** Plum



Large Rectangular Tray  
13 1/4" x 9"  
6 Pcs.

**HN002** Natural  
**HB002** Brown  
**HL002** Linen  
**HG002** Green  
**HBL01** Blue  
**HIR13** Ink  
**HGR13** Grey



Beverage Pot (13 1/2 Oz.)  
4 Pcs.

**FM729** Natural



Jug (5 1/2 Oz.)  
4 Pcs.

**FM730** Natural  
**HI145** Ink



Espresso Cup (3 1/2 Oz.) ★  
1 Dz.

**FM737** Natural  
**FP675** Ink **NEW**



Espresso Saucer 4 1/2" ★  
1 Dz.

**FM738** Natural



Mug (12 Oz.) ★  
1 Dz.

**FM739** Natural  
**HI113** Ink



Coffee/Tea Cup (8 Oz.) ★  
1 Dz.

**FM733** Natural  
**HI227** Ink  
(Fits: FM736)



Cappuccino Cup (12 Oz.) ★  
1 Dz.

**FM732** Natural  
(Fits: FM736, HI156, FP617)



Saucer 6 1/4" ★  
1 Dz.

**FM736** Natural  
**HI156** Ink



# *Harvest* NEW *Mediterranean* *Moresque*

A great pairing collection to Harvest, Mediterranean Moresque adds a sophisticated touch.





**FP614 ★**  
Coupe Plate 6 ½"  
1 Dz.



**FP616 ★**  
Coupe Bowl 7 ¼" (15 Oz.)  
1 Dz.



**FP615 ★**  
Coupe Bowl 9 ¾" (40 Oz.)  
1 Dz.



**FP685**  
Rectangular Plate  
10 ⅝" x 6 ¼"  
1 Dz.



**FP686**  
Rectangular Plate  
13 ⅝" x 6 ¼"  
6 Pcs.



**FP618 ★**  
Espresso Saucer 4 ½"  
1 Dz.  
(Fits: FP675)



**FP617 ★**  
Saucer 6 ¼"  
1 Dz.  
(Fits: FN827, HI227)

# Harvest Norse

Simplistic Norse, inspired by stripped back Nordic design is available on narrow rimmed plates, coupe rounds and rectangles. Minimal and functional tableware shapes.

Linen



Grey





Narrow Rim Plate 6" ★  
1 Dz.

**FN474** Grey  
**FN486** Linen



Narrow Rim Plate 7" ★  
1 Dz.

**FN473** Grey  
**FN485** Linen



Narrow Rim Plate 8" ★  
1 Dz.

**FN472** Grey  
**FN484** Linen



Narrow Rim Plate 9" ★  
1 Dz.

**FN471** Grey  
**FN483** Linen



Narrow Rim Plate 10" ★  
1 Dz.

**FN470** Grey  
**FN482** Linen



Narrow Rim Plate 11" ★  
1 Dz.

**FN469** Grey  
**FN481** Linen



Deep Coupe Plate 10" ★  
1 Dz.

**FN478** Grey  
**FN490** Linen



Deep Coupe Plate 11" ★  
1 Dz.

**FN477** Grey  
**FN489** Linen



Coupe Bowl (15 Oz.) ★  
7 ¼"  
1 Dz.

**FN476** Grey  
**FN488** Linen



Coupe Bowl (40 Oz.) ★  
9 ¾"  
1 Dz.

**FN475** Grey  
**FN487** Linen



Organic Rectangular Plate  
10 ⅝" x 6 ¼"  
1 Dz.

**FN479** Grey  
**FN491** Linen



Organic Rectangular Plate  
13 ⅝" x 6 ¼"  
6 Pcs.

**FN480** Grey  
**FN492** Linen



# Harvest Norse NEW White

Harvest Norse White is a design based on the simple rusticity and functionality of Nordic craftsmanship. The minimal radial lines have the appearance of hand-carved marks and are enhanced by hand-glazing to create the rustic look and feel of crafted pottery. Norse White is finished in a semi-matte glaze.





**FP182 ★**  
Narrow Rim Plate 6"  
1 Dz.



**FP181 ★**  
Narrow Rim Plate 7"  
1 Dz.



**FP180 ★**  
Narrow Rim Plate 9"  
1 Dz.



**FP179 ★**  
Narrow Rim Plate 10"  
1 Dz.



**FP184 ★**  
Coupe Bowl (15 Oz.) 7 1/4"  
1 Dz.



**FP183 ★**  
Coupe Bowl (40 Oz.) 9 3/4"  
1 Dz.



**FP189**  
Organic Rectangular Plate  
10 5/8" x 6 1/4"  
1 Dz.



**FP191**  
Organic Rectangular Plate  
13 5/8" x 6 1/4"  
6 Pcs.



**FP186 ★**  
Coffee/Teacup (8 Oz.)  
T: 3 3/4" M: 4 3/4" H: 2 1/4"  
1 Dz.



**FP187 ★**  
Cappuccino (12 Oz.)  
T: 4 1/4" M: 5 1/2" H: 2 3/4"  
1 Dz.



**FP185 ★**  
Saucer 6 1/4"  
1 Dz.



# *Organic White*

A collection of exclusive shapes. Organic White designs feature a subtle irregular edge and hand-thrown embossment. Manufactured in Dudson's Finest Vitrified body, the collection has the industrial toughness to stand up to every day use in a professional kitchen.







**FN879**  
Coupe Plate 6 3/8"  
1 Dz.



**FN878**  
Coupe Plate 9"  
1 Dz.



**FN877**  
Coupe Plate 10 3/4"  
1 Dz.



**FN876**  
Coupe Plate 11 5/8"  
1 Dz.



**FN899**  
Flat Plate 12 1/2"  
6 Pcs.



**FN880**  
Coupe Bowl (10 1/2 Oz.)  
6"  
1 Dz.



**FN898**  
Coupe Bowl (15 1/2 Oz.)  
8 1/8"  
1 Dz.



**FN897**  
Coupe Bowl (28 Oz.)  
9 3/4"  
1 Dz.



**FN884**  
Coupe Bowl (47 1/2 Oz.)  
11"  
1 Dz.



**FN924**  
Coupe Wobbly Bowl (52 7/8 Oz.)  
11 5/8"  
6 Pcs.



**FN883**  
Deep Bowl (16 1/2 Oz.)  
6 7/8" x 5 3/4"  
6 Pcs.



**FN923**  
Deep Bowl (18 Oz.)  
7 7/8" x 6 5/8"  
6 Pcs.



**FN882**  
Rectangular Tray  
11 1/4" x 7 3/4"  
6 Pcs.



**FN922**  
Rectangular Tray  
13 1/2" x 9 1/8"  
6 Pcs.



**FN881**  
Coupe Rectangular Tray  
10 5/8" x 6 1/4"  
1 Dz.



**FN885**  
Coupe Rectangular Tray  
13 3/4" x 6 1/4"  
6 Pcs.

VITRIFIED STONEWARE

# *Evo Azure* NEW

The lightness of sky blue meets the strength of granite in Evo Azure to create vessels that stimulate the senses and inspire creativity.

Evo Azure was designed to complement the timeless colors of Evo Pearl, Jet and Granite.





**FP444 ★**  
Coupe Plate 6  $\frac{3}{8}$ "  
6 Pcs.



**FP445 ★**  
Coupe Plate 8"  
6 Pcs.



**FP446 ★**  
Coupe Plate 9"  
6 Pcs.



**FP447 ★**  
Coupe Plate 10  $\frac{3}{4}$ "  
6 Pcs.



**FP448 ★**  
Coupe Plate 11  $\frac{5}{8}$ "  
6 Pcs.



**FP439 ★**  
Deep Plate 9  $\frac{1}{2}$ "  
6 Pcs.



**FP440 ★**  
Deep Plate 11  $\frac{1}{2}$ "  
4 Pcs.



**FP449 ★**  
Rice Bowl (7 Oz.)  
4  $\frac{1}{8}$ "  
6 Pcs.



**FP450 ★**  
Rice Bowl (30 Oz.)  
7"  
6 Pcs.



**FP452**  
Rectangular Tray  
10  $\frac{3}{8}$ " x 4  $\frac{3}{4}$ "  
6 Pcs.



**FP453**  
Rectangular Tray  
14" x 6  $\frac{1}{2}$ "  
4 Pcs.



**FP458**  
Olive/ Tapas Dish (5 Oz.)  
4  $\frac{5}{8}$ " x 1  $\frac{1}{4}$ "  
1 Dz.



**FP459**  
Olive/ Tapas Dish (10 Oz.)  
6  $\frac{1}{4}$ " x 1  $\frac{1}{4}$ "  
6 Pcs.

VITRIFIED STONEWARE

# *Evo*

Evo has been designed with the appearance of hand-thrown pottery and its homely charm adds a touch of warmth to any tabletop.

Pearl



Granite



Jet





Coupe Plate 6  $\frac{3}{8}$ " ★  
2 Dz.

**EG162** Granite  
**EJ162** Jet  
**EP162** Pearl



Coupe Plate 8" ★  
2 Dz.

**EG205** Granite  
**EJ205** Jet  
**EP205** Pearl



Coupe Plate 9" ★  
2 Dz.

**EG229** Granite  
**EJ229** Jet  
**EP229** Pearl



Coupe Plate 10  $\frac{3}{4}$ " ★  
2 Dz.

**EG273** Granite  
**EJ273** Jet  
**EP273** Pearl



Coupe Plate 11  $\frac{5}{8}$ " ★  
1 Dz.

**EG295** Granite  
**EJ295** Jet  
**EP295** Pearl



Flat Plate 10"  
1 Dz.

**EG254** Granite  
**EJ254** Jet  
**EP254** Pearl



Flat Plate 12  $\frac{1}{2}$ "  
8 Pcs.

**EV318** Granite  
**EJ318** Jet  
**EP318** Pearl



Deep Plate 9  $\frac{1}{2}$ " ★  
1 Dz.

**EG243** Granite  
**EJ243** Jet  
**EP243** Pearl



Deep Plate 11  $\frac{1}{2}$ " ★  
8 Pcs.

**EG292** Granite  
**EJ292** Jet  
**EP292** Pearl



Deep Oval Bowl (16 Oz.)  
6  $\frac{1}{2}$ " x 4  $\frac{3}{4}$ "  
2 Dz.

**FM913** Granite  
**FM914** Jet  
**FM915** Pearl



Deep Oval Bowl (35 Oz.)  
8  $\frac{1}{2}$ " x 6  $\frac{1}{2}$ "  
2 Dz.

**EG216** Granite  
**EJ216** Jet  
**EP216** Pearl



Deep Oval Bowl (38  $\frac{3}{4}$  Oz.)  
10  $\frac{1}{2}$ " x 7  $\frac{5}{8}$ "  
1 Dz.

**EG267** Granite  
**EJ267** Jet  
**EP267** Pearl



Chefs' Rectangular Tray  
10  $\frac{3}{8}$ " x 4  $\frac{3}{4}$ "  
1 Dz.

**EG271** Granite  
**EJ271** Jet  
**EP271** Pearl



Chefs' Rectangular Tray  
14" x 6  $\frac{1}{2}$ "  
8 Pcs.

**EG356** Granite  
**EJ356** Jet  
**EP356** Pearl



★ 2 YEAR  
EDGE CHIP  
WARRANTY

# Evo cont'd.



Rice Bowl (7 Oz.) ★  
4 1/8" x 2"  
2 Dz.

**EG105** Granite  
**EJ105** Jet  
**EP105** Pearl  
(Fits: Saucer 6 3/8")



Rice Bowl (30 Oz.) ★  
7" x 2 1/4"  
2 Dz.

**EG178** Granite  
**EJ178** Jet  
**EP178** Pearl



Dip Pot/Taster Cup (2 1/2 Oz.)  
1 1/2" x 2"  
4 Dz.

**FM759** Granite  
**FM751** Jet  
**FM743** Pearl



Olive/Tapas Dish (5 Oz.)  
4 5/8" x 1 1/4"  
4 Dz.

**FM764** Granite  
**FM756** Jet  
**FM748** Pearl



Olive/Tapas Dish (10 Oz.)  
6 1/4" x 1 1/4"  
2 Dz.

**FM765** Granite  
**FM757** Jet  
**FM749** Pearl



Teapot (28 Oz.)  
T: 3 1/4" M: 7 7/8" H: 5 1/4" B: 5 1/4"  
6 Pcs.

**FN454** Granite



Creamer (2 Oz.)  
T: 2 1/2" M: 2 1/2" H: 2"  
3 Dz.

**FM763** Granite  
**FM755** Jet  
**FM747** Pearl



Sugar Bouillon (8 Oz.)  
3 3/4" x 2 1/4"  
6 Pcs.

**FM455** Granite



Mug (11 1/4 Oz.)  
T: 3 5/8" M: 5" H: 3 3/8"  
2 Dz.

**FM760** Granite  
**FM752** Jet  
**FM744** Pearl  
(Fits: Saucer 6 3/8")



Café Au Lait Cup (10 Oz.)  
T: 3 3/4" M: 4 7/8" H: 2 3/4"  
3 Dz.

**FM761** Granite  
**FM753** Jet  
**FM745** Pearl  
(Fits: Saucer 6 3/8")



Tea Cup (8 Oz.)  
T: 3 3/4" M: 4 7/8" H: 2 1/8"  
3 Dz.

**FM758** Granite  
**FM750** Jet  
**FM742** Pearl  
(Fits: Saucer 6 3/8")



Saucer 6 3/8"  
2 Dz.

**FM762** Granite  
**FM754** Jet  
**FM746** Pearl

# Acacia Wood

Wood serveware, exclusively designed to complement the ceramic portfolio. The Acacia Wood items feature a subtle surface texture to create a rustic effect.

Double sided designs to allow for flexibility and multiple uses. Food safe and specifically designed for the hospitality industry, Dudson Wood is also sustainable and comes from a 100% renewable source.

### Pairs well with:

Dudson Evo Collection  
Dudson Harvest Collection

*\*For a full pairing guide visit: Page 351*

**\*HAND WASH ONLY**



### FN282\*

Acacia Wood MD Rectangle Handled Board  
L: 18 1/4" W: 4 3/4"  
4 Pcs.



### FN283\*

Acacia Wood LG Rectangle Handled Board  
L: 21 1/2" W: 5 1/2"  
4 Pcs.



### FN284\*

Acacia Wood Square Handled Board  
L: 14 7/8" W: 10"  
4 Pcs.



C&S  
Chef & Sommelier  
- FRANCE -

In total harmony with Chef & Sommelier glassware, the dinnerware collections are also designed to enhance presentations. Specifically, offering a beautiful canvas to chefs' creations.

Offering a variety of materials and designs, collections are made in Bone China, Stoneware or in Vitrified Ceramic celebrating the refinement, finesse and resistance within the Chef & Sommelier brand.



## Vitrified Stoneware

**Vitrified Stoneware** – Vitrified stoneware made from clay and fired at high temperature combining artisanal design with industrial strength.

Geode 194

## VITRIFIED CERAMIC

**Vitrified Ceramic** – Vitrified Ceramic has a high alumina content that contributes to the product's strength and beauty.

Eternity Plus 196



**Bone China** – Brilliant translucence developed with bone ash for maximum strength in ceramic.

Infinity 200

Infinity Coupes 202



**Stackability** – Product design specifically made for safe stacking.



**Fully Glazed Foot** – Pin-fired, fully glazed foot prevents scratching and cross contamination when product is stacked.

Stoneware

# Geode

Inspired by the Greek Geode definition, the "shape of the earth" designs feature clean and simple shapes with slight handmade touches.

NEW  
Charcoal



White



Grey



Black





Plate 4" ●  
2 Dz.

**FK788** White



B&B/Side Plate 6" ●  
1 Dz.

**FL645** White  
**FP132** Charcoal



Salad/Dessert Plate 8 ½" ●  
1 Dz.

**FL644** White  
**FK844** Black  
**FK944** Grey  
**FP134** Charcoal



Dinner Plate 10 ¾" ●  
1 Dz.

**FL643** White  
**FK843** Black  
**FK943** Grey  
**FP131** Charcoal



Bowl ●  
D: 4 ¾" H: 2 ¾" (12 Oz.)  
2 Dz.

**FK789** White  
**FK889** Black  
**FK989** Grey  
**FP130** Charcoal



Bowl ●  
D: 6" H: 2 ½" (24 Oz.)  
1 Dz.

**FL647** White



Bowl ●  
D: 8 ½" H: 1 ¾" (32 Oz.)  
1 Dz.

**FL646** White  
**FP135** Charcoal



Ramekin ●  
D: 2 ½" H: 1 ¼" (1 ¼ Oz.)  
2 Dz.

**FL648** White  
**FK848** Black  
**FK548** Grey  
**FP133** Charcoal



Mug  
H: 4" T: 3 ⅝" M: 5" (12 Oz.)  
2 Dz.

**FL651** White



Espresso/Sauce Cup  
H: 2 ¾" T: 2 ¼" B: 1 ⅝" M: 2 ¼" (4 Oz.)  
2 Dz.

**FK790** White



VITRIFIED  
CERAMIC

## *Eternity Plus*

With a fully glazed foot, Eternity Plus' classic style and long-lasting durability complements tables at the finest restaurants and hotels.



**FM556**  
Oval Platter 8 ½"  
2 Dz.

**FM551**  
Oval Platter 10 ½"  
2 Dz.



**FM564**  
Oval Platter 11 ½"  
1 Dz.

**FM539**  
Oval Platter 12 ½"  
1 Dz.



**FM566**  
Side Plate 5 3/4"  
3 Dz.

**FM538**  
B&B Plate 6 3/8"  
3 Dz.



**FM536**  
Dessert Plate 7"  
3 Dz.

**FM548**  
Salad Plate 8"  
2 Dz.

**FM558**  
Brunch Plate 9"  
1 Dz.



**FM542**  
Lunch Plate 9 1/2"  
2 Dz.

**FM547**  
Large Dessert/Salad Plate 10"  
2 Dz.

**FM569**  
Dinner Plate 10 5/8"  
1 Dz.



**FM888**  
Buffet Plate 11"  
1 Dz.

**FM544**  
Banquet Plate 11 1/2"  
1 Dz.

**FM545**  
Service Plate 12 1/2"  
1 Dz.



**FM568**  
Coupe Plate 6 5/8"  
3 Dz.

**FM553**  
Coupe Plate 8 7/8"  
1 Dz.

**FM570**  
Coupe Plate 10 1/2"  
1 Dz.



**FM560**  
Coupe Oval Plate 9 1/2"  
2 Dz.

**FM554**  
Coupe Oval Plate 12"  
1 Dz.



**FM549**  
Pizza Plate 12 1/4"  
1 Dz.



VITRIFIED  
CERAMIC

# *Eternity Plus* cont'd.



**FM550**  
Soup Plate 8 1/2" (11 Oz.)  
T: 8 1/2" H: 1 1/2"  
1 Dz.

**FM562**  
Soup Plate 9 1/2" (12 Oz.)  
T: 9 1/2" H: 1 1/2"  
1 Dz.



**FM552**  
Soup/Pasta Plate 11 3/8" (18 Oz.)  
T: 11 3/8" H: 1 5/8"  
1 Dz.



**EP777**  
Deep Oval Bowl 6 1/2" (16 Oz.)  
L: 6 1/2" W: 5" H: 2"  
1 Dz.



**FM557**  
Chefs' Bowl 8" (30 Oz.)  
T: 8" H: 2 1/4"  
1 Dz.

**FM561**  
Chefs' Bowl 10 1/2" (52 Oz.)  
T: 10 1/2" H: 2 1/4"  
3 Pcs.



**FN097 •**  
Soup Bowl (9 1/2 Oz.)  
T: 3 3/4" H: 2 1/4"  
3 Dz.



**FM567 •**  
Continental Bowl (12 Oz.)  
T: 4 5/8" H: 2 1/4"  
3 Dz.



**FM537**  
Bouillon/Sugar (7 3/4 Oz.)  
T: 4" H: 2 1/4"  
3 Dz. (Fits: FM903)



**FM555**  
Fruit Dish 4 7/8" (5 3/4 Oz.)  
T: 4 7/8" H: 1 1/8"  
3 Dz.



**FN808**  
Teapot With Lid (13 Oz.)  
L: 7" W: 4 1/2" H: 4 3/4"  
8 Pcs.



**FN809**  
Creamer No Handle (4 1/2 Oz.)  
T: 3" H: 2 3/4" M: 3"  
1 Dz.



**FM713**  
Teacup (5 1/2 Oz.)  
T: 3 1/4" H: 2 1/4" M: 4 1/4"  
3 Dz.  
(Fits: FM540)



**FM541** ●  
Teacup (8 Oz.)  
T: 3 1/8" H: 2 3/4" M: 4"  
3 Dz.  
(Fits: FM540)



**FM563** ●  
Mug (9 1/2 Oz.)  
T: 3 1/8" H: 3 1/2" M: 4 1/4"  
3 Dz.  
(Fits: FM540)



**FM543** ●  
Hudson Mug (11 1/2 Oz.)  
T: 3 1/8" H: 3 3/4" M: 4 1/2"  
3 Dz.  
(Fits: FM540)



**FM559**  
Apex Mug (12 Oz.)  
T: 3 1/2" H: 4 1/2" M: 5"  
18 Pcs.  
(Fits: FM540)



**FM546**  
Kone Mug (12 Oz.)  
T: 3 3/8" H: 4" M: 4 5/8"  
18 Pcs.  
(Fits: FM540)



**FM540**  
Teasaucer Avalon 5 5/8"  
3 Dz.



**FM902**  
Teacup (7 1/2 Oz.)  
T: 3 3/4" H: 2 1/4" M: 4 3/4"  
3 Dz.  
(Fits: FM903)



**FM904**  
Coffee Cup (11 oz.)  
T: 4 1/4" H: 2 1/2" M: 5 1/2"  
3 Dz.  
(Fits: FM903)



**FM903**  
Teasaucer 5 3/4"  
3 Dz.



**FM900**  
AD Cup (3 1/2 Oz.)  
T: 2 1/2" H: 2 1/8" M: 3 1/2"  
3 Dz.  
(Fits: FM901)



**FM901**  
AD Saucer 4 5/8"  
3 Dz.





# Infinity

Beautifully translucent and lightweight, yet strong. A favorite of upscale hotels and banquets.



**FN006**  
B&B Plate 6 3/8"  
2 Dz.

**FN004**  
Salad/Dessert Plate 8 1/4"  
2 Dz.

**FN003**  
Salad/Banquet Plate 9 5/8"  
2 Dz.

**FN002**  
Dinner Plate 11"  
1 Dz.

**FN001**  
Service Plate 11 7/8"  
1 Dz.



**FN008**  
Rim Soup/Pasta Bowl 9" (13 Oz.)  
1 Dz.



**FN011**  
Pasta Bowl 12" (20 Oz.)  
1 Dz.





**FN063**  
Oval Platter 11 ¼" x 8 ½"  
1 Dz.



**FN051**  
Bowl (7 Oz.)  
D: 5" H: 1 ½"  
2 Dz.



**FN034 •**  
Salad/Cereal Bowl (20 Oz.)  
D: 5 ½" H: 2"  
2 Dz.



**FN030 •**  
Bouillon (8 ½ Oz.)  
D: 3 ½" H: 3 ½"  
2 Dz.  
(Fits: FN033)



**FN039**  
Egg Cup (1 Egg)  
H: 2 ¾" M: 1 ⅞"  
2 Dz.



**FN019**  
Covered Teapot (13 ½ Oz.)  
T: 3 ½" M: 6 ¾" H: 4"  
1 Dz.



**FN022**  
Covered Coffee Pot (20 ¼ Oz.)  
T: 3 ¾" M: 6 ½" H: 5 ½"  
1 Dz.



**FN017**  
Creamer (3 ½ Oz.)  
T: 2 ¼" M: 4" H: 2 ½"  
2 Dz.



**FN018**  
Creamer (6 ¾ Oz.)  
T: 2 ½" M: 4 ¼" H: 3"  
1 Dz.



**FN026 •**  
AD Cup (3 ½ Oz.)  
T: 2" M: 3 ⅜" H: 2"  
2 Dz.

**FN031**  
AD Saucer 4 ½"  
2 Dz.



**FN038 •**  
Coffee/Teacup (8 ½ Oz.)  
T: 3 ½" M: 4 ½" H: 2 ½"  
2 Dz.



**FN028**  
Coffee Cup (9 Oz.)  
T: 3 ½" M: 4 ½" H: 3 ¼"  
2 Dz.



**FN033**  
Double Well Saucer 6"  
2 Dz.  
(Fits: FN028, FN030, FN038)





## *Infinity Coupes*

Our Infinity design takes a new turn. The same elegant and durable Bone China now comes in a rimless coupe shape for a more contemporary appeal.





**FN513**  
Coupe B&B Plate 6 1/4"  
2 Dz.



**FN512**  
Coupe Salad/Dessert Plate 8 1/4"  
2 Dz.



**FN511**  
Coupe Salad/Banquet Plate 9 1/2"  
2 Dz.



**FN514**  
Coupe Deep Plate 10 3/4" (35 Oz.)  
1 Dz.



**FN510**  
Coupe Dinner Plate 10 5/8"  
1 Dz.



**FN509**  
Coupe Service Plate 12"  
1 Dz.



**FN516**  
Coupe Oval Platter 10 3/4" x 8"  
1 Dz.



# ARCOROC

Resistant to the pressure and intense pace of professional use, Arcoroc's dinnerware collections have many technical advantages that allow for optimal service.

Arcoroc makes resistance its priority. Aluminite, a bright, new body strengthened with extra alumina for added durability, is the main ceramic material in this brand.





## ALUMINITE<sup>+</sup>

Aluminite® – With over 100 SKUs, the same body in multiple collections. Developed with superior strength for professional use.

Athena <i>NEW</i>	206
Candour	208
Candour Azure	210
Candour Cirrus	212
Candour Coupes	214
Horizon	216
Rondo	218
Universal <i>NEW</i>	220
Vintage	222



Stackability – Product design specifically made for safe stacking.

# Athena NEW

Athena is a collection that combines soft, elegant lines with superior strength.





**FP308**  
B&B Plate 6 1/4"  
2 Dz.



**FP307**  
Salad/Dessert Plate 8 1/2"  
2 Dz.



**FP306**  
Banquet Plate 10"  
2 Dz.



**FP305**  
Dinner Plate 11 1/4"  
1 Dz.



**FP309**  
Rim Soup (9 1/2 Oz.)  
9 1/2"  
2 Dz.



**FP313**  
Cup (8 Oz.)  
H: 2 3/4" T: 3 5/8" M: 4 1/2"  
2 Dz.



**FP314**  
Saucer 6 1/2"  
2 Dz.



**FP312**  
Oval Platter  
10 1/4" x 7 3/4"  
1 Dz.



**FP311**  
Oval Platter  
13" x 9 3/4"  
1 Dz.



**FP310**  
Oval Platter  
14 1/2" x 11"  
1 Dz.

# Candour

Wide rims, flat profiles and space-saving stackability. Matches all collections in the Aluminite body.



**R0806**  
B&B Plate 6 ¼"  
2 Dz.

**R0805**  
Side Plate 7 ⅜"  
2 Dz.

**R0804**  
Salad Plate 8 ½"  
2 Dz.

**R0803**  
Brunch Plate 10"  
2 Dz.

**R0802**  
Banquet Plate 10 ½"  
1 Dz.

**R0801**  
Dinner Plate 11 ½"  
1 Dz.

**R0811**  
Service Plate 12"  
1 Dz.



**R0852** ●  
Bowl 2 ¾" (2 ¼ Oz.)  
2 Dz.

**R0851** ●  
Bowl 4" (8 Oz.)  
2 Dz.

**R0850** ●  
Bowl 5 ⅛" (16 ¾ Oz.)  
2 Dz.



NEW



**FP359**  
Rim Plate 10 1/4"  
1 Dz.



**R0809**  
Pasta Bowl 11 3/4" (18 1/2 Oz.)  
1 Dz.



**FM381**  
Pizza Plate 12 1/2"  
1 Dz.



**R0807**  
Soup Plate 8 3/4" (12 Oz.)  
1 Dz.



**R0840** ●  
Soup Bowl 3 3/4" (9 Oz.)  
2 Dz.  
(Fits: R0833)



**R0830** ●  
Soup Bowl 4 1/2" (12 1/2 Oz.)  
2 Dz.



**R0839** ●  
Cup (9 3/4 Oz.)  
H: 2 1/4" W: 3 3/4"  
2 Dz.

**R0833**  
Saucer 6 1/2"  
2 Dz.  
(Fits: R0840, R0830)



**R0835** ●  
Mug (11 Oz.)  
H: 3" W: 3 1/2"  
2 Dz.



**R0817** ●  
Creamer (3 1/2 Oz.)  
H: 2 3/4" W: 2 1/8"  
16 Pcs.



**R0819**  
Teapot (15 Oz.)  
H: 4 1/4" W: 3 1/2"  
8 Pcs.



**R0882**  
Vase (6 1/4 Oz.)  
H: 5 1/2" W: 3"  
16 Pcs.



## *Candour Azure*

Create a unique color impact with blue and white pattern combinations. Complement the line as an accent piece with any pattern in the Aluminite body.





**FK643**  
Coupe B&B Plate 6 1/2"  
2 Dz.



**FK640**  
Coupe Salad/Dessert Plate 8 1/8"  
2 Dz.



**FK639**  
Coupe Dinner/Banquet Plate 10 3/4"  
2 Dz.



**FK641**  
Coupe Brunch Plate 9"  
2 Dz.



**FK642**  
Coupe Deep Soup Plate (24 1/2 Oz.)  
8 1/8"  
2 Dz.



**FK644**  
Coupe Oval Platter 10 3/8" x 7 3/8"  
1 Dz.



**FK645**  
Coupe Oval Platter 12 1/4" x 8 7/8"  
1 Dz.



**FK646**  
Coupe Oval Platter 14 1/4" x 10"  
1 Dz.

## *Candour Cirrus*

Eye-catching swept embossment designs create the perfect harmony between refined beauty and long lasting resistance for high volume operations.





**FK769**  
B&B Plate 6 1/4"  
2 Dz.



**FK768**  
Side Plate 7 3/8"  
2 Dz.



**FK767**  
Salad Plate 8 1/2"  
2 Dz.



**FK766**  
Brunch Plate 10"  
2 Dz.



**FK765**  
Banquet Plate 10 1/2"  
1 Dz.



**FK764**  
Dinner Plate 11 1/2"  
1 Dz.



**FK763**  
Service Plate 12"  
1 Dz.



**FK774**  
Pasta Bowl (18 1/2 Oz.)  
11 3/4"  
1 Dz.



**FK770**  
Soup Bowl (12 Oz.)  
8 3/4"  
1 Dz.



**FK777** ●  
Cup (9 3/4 Oz.)  
H: 2 1/4" W: 3 3/4"  
2 Dz.

**FK775**  
Saucer 6 1/2"  
2 Dz.



# *Candour Coupes*

Simply Smart. With the strength of Aluminite, Candour is a go-to favorite with customers for its long lasting resistance. Now with a rimless design, elegance has never seemed so simple.





**FH288**  
Coupe B&B Plate 6 1/2"  
2 Dz.

**FH286**  
Coupe Salad/Dessert Plate 8 1/8"  
2 Dz.

**FH285**  
Coupe Dinner/Banquet Plate 10 3/4"  
2 Dz.

**FM382**  
Coupe Plate 11 1/2"  
1 Dz.



**FH621**  
Coupe Deep Soup Plate (24 1/2 Oz.)  
8 1/8"  
2 Dz.



**FH608**  
Coupe Brunch Plate 9"  
2 Dz.



**FH287**  
Coupe Bowl (20 Oz.)  
6 1/8"  
2 Dz.



**FH289**  
Coupe Bowl (101 1/2 Oz./3 L)  
9 1/4"  
6 Pcs.



**FH609**  
Coupe Oval Platter 10 3/8" x 7 3/8"  
1 Dz.

**FH610**  
Coupe Oval Platter 12 1/4" x 8 7/8"  
1 Dz.

**FH611**  
Coupe Oval Platter 14 1/4" x 10"  
1 Dz.



**FH614**  
Mug (10 1/2 Oz.)  
H: 3 3/8" T: 3 1/8" M: 4 3/8"  
2 Dz.



**FH615**  
Mug (14 Oz.)  
H: 4 1/8" T: 3 3/8" M: 4 1/2"  
2 Dz.

# *Horizon*

Embossed rays brighten any table.







**S0606**  
B&B/Side Plate 6 1/2"  
3 Dz.

**S0604**  
Salad/Dessert Plate 8 1/4"  
3 Dz.



**S0603**  
Brunch Plate 9 1/4"  
2 Dz.

**S0602**  
Dinner Plate 11"  
2 Dz.



**S0628**  
Coffee/Teacup (7 Oz.)  
H: 4 1/2" T: 3 1/4" M: 4 1/2"  
2 Dz.

**S0633**  
Saucer/Bouillon Saucer 6"  
2 Dz.  
(Fits: S0630)



**S0638** ●  
Coffee/Teacup (8 Oz.)  
H: 2 1/2" T: 3 1/4" M: 4 1/2"  
2 Dz.

**S0633**  
Saucer/Bouillon Saucer 6"  
2 Dz.  
(Fits: S0630)



**S0630** ●  
Bouillon Cup/Open Sugar (9 Oz.)  
H: 3 3/4" M: 3 3/4"  
2 Dz.  
(Fits: S0633)



**S1916**  
Sugar Caddy  
H: 2 1/8" L: 3 5/8" W: 2 3/8"  
1 Dz.



# *Rondo*

Wide rims and deep coupe plates feature soft concentric rings.





**S1506**  
B&B/Side Plate 6 3/4"  
3 Dz.

**S1504**  
Salad/Dessert Plate 8 5/8"  
3 Dz.



**S1503**  
Brunch Plate 9 7/8"  
3 Dz.

**S1502**  
Dinner Plate 11"  
2 Dz.

**S1501**  
Service Plate 12"  
1 Dz.



**S1509**  
Coupe Deep Plate 12"  
1 Dz.



**S1550**  
Fruit/Side Dish (4 Oz.)  
4 3/4"  
3 Dz.



**S1508**  
Coupe Bowl (14 Oz.) 7"  
3 Dz.

**S1512**  
Coupe Bowl (30 Oz.) 9"  
3 Dz.



**S1507**  
Rim Soup/Pasta Bowl (8 Oz.)  
9 1/4"  
2 Dz.



**S1534**  
Grapefruit/Cereal Bowl  
H: 2 5/8" M: 4 3/8" (17 Oz.)  
3 Dz.



**S1517**  
Small Creamer (4 1/2 Oz.)  
H: 3 1/8" T: 2" M: 4 3/8"  
2 Dz.



**S1518**  
Large Creamer (8 1/2 Oz.)  
H: 3 3/8" T: 2 1/2" M: 5 1/8"  
1 Dz.



**S1521**  
Teapot with Cover (20 Oz.)  
6 3/4"  
1 Dz.



**S1530** ●  
Bouillon Cup (11 Oz.)  
H: 2 5/8" M: 3 3/4"  
2 Dz.  
(Fits: S1533)



**S1535** ●  
Coffee Mug (10 Oz.)  
H: 3 1/2" T: 3 1/8" M: 4 3/8"  
1 Dz.



**S1538** ●  
Coffee/Teacup (8 Oz.)  
H: 2 1/2" T: 3 1/2" M: 4 5/8"  
2 Dz.

**S1533**  
Saucer/Bouillon Saucer 6 3/4"  
2 Dz.  
(Fits: S1530)



**S1528**  
Tall Coffee/Teacup (8 Oz.)  
H: 3 1/4" T: 3 1/2" M: 4 3/8"  
2 Dz.

**S1533**  
Saucer/Bouillon Saucer 6 3/4"  
2 Dz.  
(Fits: S1530)



# *Universal*

NEW

A collection of accessories in the Aluminite body to complement all of the Aluminite collections.





**FP361**  
 Universal Rectangle Platter  
 12 ½" x 6"  
 1 Dz.



**FP366**  
 Rim Oval Platter  
 10" x 7"  
 1 Dz.



**FP367**  
 Rim Oval Platter  
 12" x 8 ⅝"  
 1 Dz.



**FP368**  
 Rim Oval Platter  
 14 ¼" x 10 ¼"  
 8 Pcs.



**FP362**  
 Onion Soup (12 Oz.)  
 6" x 5 ¼" x 2 ¼"  
 2 Dz.  
 (Can go in a conventional oven  
 392°F/200°C) 2 hours



**FP363**  
 Oval Baker (11 Oz.)  
 6 ⅞" x 4 ¼" x 1 ¾"  
 1 Dz.  
 (Can go in a conventional oven  
 392°F/200°C) 2 hours



**FP370**  
 Sauce Pot (1 ½ Oz.)  
 H: 1 ½" D: 2"  
 2 Dz.



**FP369**  
 Butter/Sauce Dish (2 Oz.)  
 4 ¼" x 3"  
 2 Dz.



**FP364**  
 Salt Shaker  
 H: 3 ½" T: 1" B: 1 ¾"  
 16 Pcs.



**FP365**  
 Pepper Shaker  
 H: 3 ½" T: 1" B: 1 ¾"  
 16 Pcs.

# Vintage

Scooped rims and deep-welled platters create timeless appeal.



**R0906**  
B&B Plate 6 3/4"  
2 Dz.

**R0905**  
Side Plate 7 1/4"  
2 Dz.

**R0904**  
Salad Plate 8"  
2 Dz.

**R0903**  
Brunch Plate 9 3/4"  
2 Dz.

**R0902**  
Dinner Plate 10 1/2"  
1 Dz.

**R0901**  
Service Plate 12 1/4"  
1 Dz.



**R0907**  
Soup Plate (10 Oz.)  
9 1/2"  
1 Dz.



**R0950**  
Square Bowl (12 ½ Oz.)  
4 ½"  
2 Dz.



**R0908**  
Soup/Cereal Bowl (16 ¾ Oz.)  
7"  
2 Dz.



**R0947**  
Bowl (69 Oz.)  
8 ¾"  
16 Pcs.



**R0960**  
Rectangular Dish  
L: 13" W: 7 ¼"  
8 Pcs.

**R0959**  
Rectangular Dish  
L: 14 ½" W: 7 ½"  
8 Pcs.



**R0968**  
Rectangular Dish  
L: 11" W: 9 ¼"  
1 Dz.



**R0919**  
Teapot (12 Oz.)  
H: 4 ¼" W: 4 ½"  
8 Pcs.



**R0917**  
Creamer (4 Oz.)  
H: 4 ½" W: 2 ½"  
16 Pcs.



**R0918**  
Jug (12 ½ Oz.)  
H: 6 ⅝" W: 3 ⅞"  
8 Pcs.



**R0926**  
Cup (3 Oz.)  
H: 2" W: 2 ½"  
2 Dz.

**R0931**  
Saucer 4 ¾"  
2 Dz.



**R0928**  
Cup (8 Oz.)  
H: 2 ½" W: 3 ½"  
2 Dz.

**R0932**  
Saucer 5 ¾"  
2 Dz.



**R0929**  
Cup (11 ¾ Oz.)  
H: 2 ¾" W: 4"  
2 Dz.

**R0933**  
Saucer 7"  
2 Dz.









**Extra Strong Porcelain** – Developed for professional use; superior mechanical resistance.

Appetizer	226
Daring	226
Square Up	227



**Stackability** – Product design specifically made for safe stacking.

# Appetizer

Accessory pieces that fit everything from hors d'oeuvres to condiments.

Shown Rectangular Plate 5 5/8"



**R0738**  
Spoon 4 1/8" (1/2 oz.)  
2 Dz.



**R0735**  
Deep Square Bowl  
3 3/8" (4 1/2 Oz.)  
2 Dz.



**R0741**  
Deep Bowl 3 3/4" (5 Oz.)  
2 Dz.



**R0736**  
Rectangular Plate  
5 5/8" x 2 3/4"  
2 Dz.

# Daring

Extra Strong Porcelain accessory pieces designed to complement our Intensity White and Restaurant White lines.



**G3754**  
Fruit Dish (2 1/2 Oz.)  
4 1/2"  
2 Dz.

**G3753**  
Grapefruit/Cereal Bowl (6 3/4 Oz.)  
6 1/4"  
2 Dz.



**G3765** ●  
Bouillon (8 Oz.)  
H: 2 1/16" M: 4"  
2 Dz.



**G3745** ●  
Coffee/Teacup (7 1/4 Oz.)  
H: 2 3/8" M: 4 1/4"  
2 Dz.

**G3751**  
Double Well Saucer 6"  
2 Dz.



**G3752**  
Mug (10 Oz.)  
H: 3 1/2" M: 4 1/4"  
2 Dz.



# Square Up

Popular square shapes get a boost from flared sides.



**FF202**  
Bowl (1 ½ Oz.)  
L: 3" W: 2 ½" H: ¾"  
3 Dz.



**FF198**  
Flared Bowl (4 ½ Oz.)  
L: 3 ¾" W: 3 ¾" H: 1 ¾"  
3 Dz.



**FF201**  
Flared Bowl (2 Oz.)  
L: 3" W: 3" H: 1 ½"  
3 Dz.

**FF200**  
Flared Bowl (4 Oz.)  
L: 4" W: 4" H: 1 ½"  
3 Dz.

**FF199**  
Flared Bowl (14 Oz.)  
L: 5" W: 5" H: 2 ¾"  
3 Dz.



**FF192**  
Side Plate 6 ½"  
3 Dz.

**FF193**  
Side/Share Plate 7 ½"  
2 Dz.

**FF194**  
Brunch/Salad Plate 9"  
1 Dz.

**FF195**  
Dinner Plate 11"  
6 Pcs.



**FF196**  
Rectangular Platter  
12 ½" x 8"  
1 Dz.





Maria Portugal Terracota pieces are inspired by ancient processes and traditions from the history of ceramics and the visual richness found in Portugal, but also the adventure of new challenges and trends.

Production is industrial, focused on efficiency and environmental sustainability. The decoration is all handmade, which allows for a unique and distinctive handcrafted touch in all the pieces.



## Stoneware

**Stoneware** – Vitrified stoneware ceramic made from clay and fired at high temperatures combining artisanal design with industrial strength.

Terra **NEW**

230

# Terra NEW

Terra draws inspiration from the company's origins; organic, earthy shapes that look like hand-thrown ceramic. Variations in color add to the uniqueness of each piece with a touch of charming rusticity, while the twice fired stoneware body makes it perfect for professional environments.

Green

Sienna

Grey





Dinner Plate 11 1/2"  
4 Pcs.

- FP384** Green
- FP399** Sienna
- FP414** Grey



Salad Plate 9 1/2"  
6 Pcs.

- FP385** Green
- FP400** Sienna
- FP415** Grey



Dessert Plate 7 1/2"  
6 Pcs.

- FP386** Green
- FP401** Sienna
- FP416** Grey



Large Bowl (40 Oz.)  
D: 7 7/8" H: 2 1/4"  
6 Pcs.

- FP387** Green
- FP402** Sienna
- FP417** Grey



Small Bowl (15 Oz.)  
D: 5 5/8" H: 1 3/4"  
6 Pcs.

- FP388** Green
- FP403** Sienna
- FP418** Grey



Au Gratin (5 Oz.)  
L: 5 1/8" W: 3 1/8" H: 1 3/4"  
2 Pcs.

- FP393** Green
- FP408** Sienna
- FP423** Grey



Au Gratin (30 Oz.)  
D: 6 1/8" H: 3"  
2 Pcs.

- FP394** Green
- FP409** Sienna
- FP424** Grey



Small Casserole With Lid (17 Oz.)  
D: 5 1/2" H: 3 3/4"  
2 Pcs.

- FP395** Green
- FP410** Sienna
- FP425** Grey



Oval Baker (40 Oz.)  
L: 11 5/8" W: 6 5/8" H: 2 1/8"  
1 Pc.

- FP398** Green
- FP413** Sienna
- FP428** Grey



\*Oven Safe: 428°F (220°C) approx. 1 hour. When taking product out of the oven it is important to put it on neutral temperature surface & to use oven mitts.



**A Canvas for Chefs. Inspire. Create. Plate.**  
A mix of matte stoneware with metal & wood accessories  
creates a unique experience for a variety of cuisines.

Santa Anita is a ceramic leader in Mexico. With over 30 years  
of experience, Santa Anita has been a leading brand of  
high-quality stoneware products.





## Stoneware

**Vitrified Stoneware** – Vitrified stoneware made from clay and fired at high temperatures combining artisanal design with industrial strength.

Reflections <b>NEW</b>	234
Reflections Blue Band <b>NEW</b>	236
Accessories	238



Stackability – Product design specifically made for safe stacking.

# Reflections NEW

Reflections is a collection perfectly adaptable to a variety of cuisines like Asian, Latin American, and Mediterranean to name a few. The possibilities are defined by the Chef's imagination.

Glacier



Slate



Onyx





Side Plate 7 1/2"  
1 Dz.

**FP237** Onyx  
**FP250** Glacier  
**FP263** Slate



Salad/Dessert Plate 9"  
1 Dz.

**FP236** Onyx  
**FP249** Glacier  
**FP262** Slate



Dinner Plate 11"  
1 Dz.

**FP235** Onyx  
**FP248** Glacier  
**FP261** Slate

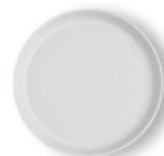

Gourmet Plate 7"  
1 Dz.

**FP247** Onyx  
**FP260** Glacier  
**FP273** Slate

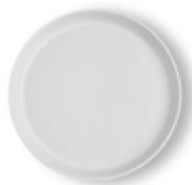

Gourmet Plate 7 7/8"  
1 Dz.

**FP246** Onyx  
**FP259** Glacier  
**FP272** Slate



Gourmet Plate 9 1/2"  
1 Dz.

**FP245** Onyx  
**FP258** Glacier  
**FP271** Slate



Gourmet Plate 10 1/8"  
1 Dz.

**FP244** Onyx  
**FP257** Glacier  
**FP270** Slate



Gourmet Plate 11 1/4"  
6 Pcs.

**FP286** Onyx  
**FP287** Glacier  
**FP288** Slate



Saucepan with Handles  
T: 8 1/2" M: 9" H: 1 1/2"  
6 Pcs.

**FP240** Onyx  
**FP253** Glacier  
**FP266** Slate



Round Bowl (12 Oz.)  
D: 4 7/8" H: 2 1/8"  
3 Dz.

**FP242** Onyx  
**FP255** Glacier  
**FP268** Slate



Round Bowl (17 Oz.)  
D: 5 7/8" H: 2 1/2"  
2 Dz.

**FP239** Onyx  
**FP252** Glacier  
**FP265** Slate



Flair Bowl (13 Oz.)  
D: 4 7/8" H: 2 3/8"  
6 Pcs.

**FP241** Onyx  
**FP254** Glacier  
**FP267** Slate



Bouillon (7 1/2 Oz.)  
D: 3 7/8" H: 2 3/8"  
6 Pcs.

**FP243** Onyx  
**FP256** Glacier  
**FP269** Slate



Mug (10 1/2 Oz.)  
T: 3 1/4" M: 4 3/4" H: 4"  
1 Dz.

**FP238** Onyx  
**FP251** Glacier  
**FP264** Slate



\*Oven Safe: 356°F (180°C) approx. 30 minutes. When taking product out of the oven it is important to put it on neutral temperature surface & to use oven mitts.



# Reflections NEW Blue Band



The light touch of a blue band will bring focus to any menu by framing the ingredients with delicate sophistication. Mix with Reflections Glacier to bring more versatility to any tabletop.



**FP466**  
Side Plate 7 1/2"  
1 Dz.



**FP465**  
Salad/Dessert Plate 9"  
1 Dz.



**FP464**  
Dinner Plate 11"  
1 Dz.



**FP470**  
Gourmet Plate 7"  
1 Dz.



**FP469**  
Gourmet Plate 7 7/8"  
1 Dz.



**FP468**  
Gourmet Plate 9 1/2"  
1 Dz.



**FP467**  
Gourmet Plate 10 1/2"  
1 Dz.



\*Oven Safe: 356°F (180°C) approx. 30 minutes. When taking product out of the oven it is important to put it on neutral temperature surface & to use oven mitts.

# Accessories

NEW

Mix wood and metal accessories to serve up delicious appetizers or entrees.





**FP315**  
Taco Holder  $\frac{2}{3}$  Black PVD  
H: 2" L: 8  $\frac{1}{2}$ " W: 4"  
2 Dz.



**FP316**  
French Fry Holder Black PVD  
H: 4" L: 4  $\frac{1}{2}$ " W: 5  $\frac{1}{4}$ "  
2 Dz.



**FP317**  
Wood Tray 3 Double Wells  
14  $\frac{1}{2}$ " x 4  $\frac{3}{4}$ "  
6 Pcs.  
(Fits: FP316, FP243, FP256, FP269, FP315)



**FP318**  
Wood Soup/Salad/Sandwich Board  
14" x 8"  
6 Pcs.  
(Fits: FP242, FP255, FP268, FP239, FP252,  
FP265, FP241, FP254, FP267)



Shown: FP315, FP316, FP317



# ARCOROC

Resistant to the pressure and intense pace of professional use, Arcoroc's dinnerware collections have many technical advantages that allow for optimal service.

Arcoroc makes resistance its priority. Opal, a tempered glass that is 3x more resistant than ceramic, is an ideal solution for a long lasting service.





**Opal®** – Preferred by high volume establishments for strength, stackability, bacteria resistance, style and value.

Brush	242
Evolutions	244
Intensity White	246
Restaurant White	248
Smart Cuisine	250



**Fully Tempered** – Preferred by high volume establishments for strength, style and value.



**0% Bacteria** – Opal® material is non-porous and resistant to bacteria.



**Stackability** – Product design specifically made for safe stacking.

# *Brush Blue Jean*

Brush is ideal for serving menus with dietary restrictions.





**H3609**  
B&B Plate 6"  
2 Dz.



**H3608**  
Side Plate 7 1/2"  
2 Dz.



**H3607**  
Lunch Plate 9 1/4"  
2 Dz.



**P3946**  
Dinner Plate 10"  
1 Dz.



**H3610**  
Soup Plate (23 Oz.)  
9"  
2 Dz.



**H3611**  
Fruit Bowl (3 1/2 Oz.)  
4 3/8"  
3 Dz.



**H3615 •**  
Bowl (10 1/2 Oz.)  
4 3/4"  
3 Dz.



**H3612 •**  
Square Dish (8 Oz.)  
4 1/4"  
2 Dz.



# *Evolutions*

Casual dining to buffets, Evolutions offers the complete solution with a mix of plates, platters and serving pieces for every cuisine.



**N9362**  
Coupe Dessert Plate 7 1/4"  
2 Dz.



**N9361**  
Coupe Plate 10"  
2 Dz.

**N9360**  
Coupe Plate 10 5/8"  
2 Dz.



**N9411**  
Coupe Soup (26 1/4 Oz.)  
7 3/4"  
2 Dz.

**P0447**  
Deep Plate (40 1/2 Oz.)  
10 1/8"  
2 Dz.



**N9364**  
Oval Platter  
9 3/4" x 13"  
1 Dz.



**L2808**  
Rectangular Plate 8 1/4" x 7 1/4"  
2 Dz.

**L2804**  
Rectangular Plate 11" x 9"  
2 Dz.



**L2810**  
Pizza Plate 12 1/2"  
1 Dz.

**E8007**  
Rectangular Platter 13 3/4" x 9 1/4"  
6 Pcs.



**L2811**  
Steak Plate  
11 3/4" x 10"  
1 Dz.



**L2805**  
Pasta Plate (18 1/2 Oz.)  
11 1/8"  
1 Dz.



**P9773** ●  
Bowl (20 1/4 Oz.) 6 1/16"  
1 Dz.

**P9772** ●  
Bowl (32 Oz.) 8 1/4"  
1 Dz.

**P9771** ●  
Bowl (47 Oz.) 9 7/8"  
1 Dz.



Shown Coupe Plate 10", Bowl (13 ½ Oz.)

## *Evolutions Granite*



**P1122**  
Coupe Dinner Plate 10 5/8"  
2 Dz.



**N9397**  
Ramekin (6 ¼ Oz.)  
3 ½"  
3 Dz.



**V2159**  
Bowl (13 ½ Oz.) 4 5/8"  
3 Dz.

**N9395**  
Bowl (25 ¼ Oz.) 5 5/8"  
2 Dz.

**N9365**  
Bowl (33 ¾ Oz.) 7"  
1 Dz.

**D7410**  
Bowl (71 ¼ Oz.) 8 ¼"  
1 Dz.

## *Evolutions Black*



**P1139**  
Pizza Plate 12 ½"  
1 Dz.

# *Intensity White*

Elegant and clean, Intensity White pairs well with all Opal Dinnerware products.





**V1540**  
B&B Plate 6 ¼"  
2 Dz.



**V1539**  
Salad Plate 8"  
2 Dz.

**V1537**  
Plate 9 ½"  
2 Dz.



**V1536**  
Banquet Plate 10"  
1 Dz.



**V1653**  
Dinner Plate 10 ¾"  
1 Dz.



**V1538**  
Rim Soup/Pasta Bowl (11 ¾ Oz.)  
8 ½"  
2 Dz.

# Restaurant White

Elegant and clean, Restaurant White pairs well with all Opal Dinnerware products.



**58621**  
Narrow Rim B&B Plate 6"  
2 Dz.

**57974**  
Narrow Rim Side Plate 7 1/2"  
2 Dz.

**57975**  
Narrow Rim Lunch Plate 9 1/4"  
2 Dz.

**N6393**  
Narrow Rim Dinner Plate 10 1/4"  
1 Dz.



**22506**  
Wide Rim B&B Plate 6"  
2 Dz.

**22530**  
Wide Rim Side Plate 7 1/2"  
2 Dz.

**22522**  
Wide Rim Lunch Plate 9 3/8"  
2 Dz.

**P3972**  
Wide Rim Dinner Plate 10"  
2 Dz.  
(Old SKU: 24742)

Shown Narrow Rim Plate 9 3/4",  
Narrow Rim Plate 6", Fruit Bowl (3 1/2 Oz.)





**29337**  
Hospital Heat System Plate 8 3/4"  
2 Dz.



**L6850**  
Deep Plate 9 3/4"  
1 Dz.



**P3967**  
Oval Platter 11 1/2"  
1 Dz.



**22514**  
Rim Soup (23 Oz.) 9"  
2 Dz.



**25285**  
Fruit Bowl (3 1/2 Oz.) 4 3/4"  
3 Dz.



**28891** ●  
Double Handled Bowl (10 1/2 Oz.)  
H: 2 1/4" M: 4"  
2 Dz.

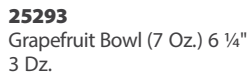

**25293**  
Grapefruit Bowl (7 Oz.) 6 1/4"  
3 Dz.



**43319** ●  
Bowl (10 1/2 Oz.)  
4 3/4"  
3 Dz.



**50061**  
Multi-Usage Bowl (15 Oz.)  
6 1/4"  
2 Dz.



**25269** ●  
Tall Cup (7 1/2 Oz.)  
H: 2 7/8" M: 3"  
4 Dz.



**14611** ●  
Cup (8 Oz.)  
H: 2 3/4" M: 3 1/4"  
3 Dz.



**36140** ●  
Mug (8 Oz.)  
H: 3 1/2" T: 2 3/4" B: 2 1/2" M: 4"  
3 Dz.



**64733** ●  
Mug (10 Oz.)  
H: 3 1/2" M: 4 3/8"  
3 Dz.

**22712**  
Saucer 5 7/8"  
3 Dz.

**22712**  
Saucer 5 7/8"  
3 Dz.





SMART CUISINE  
**475°F / 250°C**

Oven Glass  
Extra Light - Extra Resistant

## *Smart Cuisine*

Same key components as Opal with a different tempering process to allow for oven use.

Most oven ware products are limited in design, too heavy or too fragile and chips easily but not SMART CUISINE. Design offers easy to grip handles and deep wells for dishes with sauces. This collection of oven to tableware couples durability and style.





**N3295**  
Ramekin (9 ¼ Oz.)  
H: 4 ¾"  
1 Dz.



**P0310**  
Crême Brulee Dish (9 ½ Oz.)  
H: 5 ½"  
1 Dz.



**P4025**  
Square Dish (33 ¾ Oz.)  
L: 8" W: 8" H: 1 ¾"  
8 Pcs.



**P8332**  
Rectangular Dish (61 Oz.)  
L: 11 ¾" W: 9" H: 2"  
6 Pcs.



**P0887**  
Oval Dish (17 Oz.)  
L: 8 ¼" W: 5 ½" H: 1 ½"  
6 Pcs.



**N3567**  
Oval Dish (44 Oz.)  
L: 11 ¾" W: 6 ¾" H: 2 ½"  
6 Pcs.







**Fully Tempered Glass** – Preferred by high volume establishments for strength, style and value.

Arcade	254
Fleur	254
ROC	254
Stack Bowls	255
Non-Tempered	
Dessert	255



**Stackability** – Product design specifically made for safe stacking.

# Arcade

Elegantly fluted bowls for all your serving needs.



**00556**  
Bowl (11 Oz.) 5"  
12 Dz.

**M0090**  
Bowl (22 Oz.) 6"  
2 Dz.



**N7945**  
Bowl (38 Oz.) 7"  
1 Dz.

**N2608**  
Bowl (72 Oz.) 9"  
1 Dz.

# Fleur

Our iconic petal shape adorns banquets and buffets everywhere.



**J0232**  
Dessert Plate 7 1/2"  
3 Dz.

**J0856**  
Dinner Plate 9"  
3 Dz.



**J0226**  
Soup/Deep Salad Bowl (15 Oz.)  
8"  
3 Dz.

# ROC

Indentations around the rim offer a vintage feel.



**01141**  
Dinner Plate 9 1/8"  
3 Dz.



**01166**  
Dessert Plate 6"  
3 Dz.

**01158**  
Salad Plate 7 1/2"  
3 Dz.

# Stack Bowls

ARCOROC

The Stack Bowl is versatile in size and functional in design.  
The stacking ledge is optimal for space saving and easy storage.



**E9155**  
Bowl (1 ¼ Oz.) 2 ½"  
3 Dz.

**E9156**  
Bowl (2 ¾ Oz.) 3"  
3 Dz.

**E9157**  
Bowl (5 Oz.) 3 ½"  
3 Dz.



**E9158**  
Bowl (7 ½ Oz.) 4 ⅛"  
3 Dz.

**E9159**  
Bowl (12 Oz.) 4 ¾"  
3 Dz.



**G2712**  
Bowl (39 Oz.) 6 ⅝"  
3 Dz.



**V7655**  
Bowl (144 Oz.)  
10 ¼"  
6 Pcs.

## Dessert\*

Showcase your sweet creations  
with sophistication and style.

\*Non-tempered



**L6689**  
Maeva Diamant Dessert Bowl (6 ¾ Oz.)  
H: 2 ⅝" T: 4" B: 2" M: 4"  
2 Dz.



**58010**  
Palmier Dessert (7 Oz.)  
H: 3 ⅞" T: 4 ⅞"  
B: 2 ¾" M: 4 ⅞"  
2 Dz.



**V7429**  
Swirl Optic Dessert (7 Oz.)  
H: 3 ⅞" T: 3 ⅞"  
B: 2 ¾" M: 3 ⅞"  
2 Dz.



**V7431**  
Swirl Optic Dessert (12 Oz.)  
H: 3 ¾" T: 4 ⅝"  
B: 3 ¼" M: 4 ⅝"  
2 Dz.



**58012**  
Palmier Dessert (12 ½ Oz.)  
H: 7 ⅞" T: 4 ¾"  
B: 3 ¼" M: 4 ¾"  
2 Dz.

# *Flatware*





# Crafted Excellence

Crafted from the highest quality stainless steel which is an alloy of steel with chromium and/or added elements resistant to rust and corrosion.

## What is Stainless Steel?

Stainless steel is a durable and affordable metal that is used for a wide variety of purposes. It's strong, making it perfect for flatware and it's corrosion resistant, so it can last a long time without being replaced.

## Chromium

Chromium is an essential element used in stainless steel for its durability and rust/stain resistant properties.

## Nickel

Nickel is an element added to bring strength to the flatware as well as a soft luster similar to silver, producing a bright and polished look and also gives added resistance to corrosion.

### Chromium / Nickel

1st Number / 2nd Number

## 18/10 Stainless Steel *(304 Stainless)*

Contains 18% chromium and 10% nickel. 18/10 is the highest quality stainless steel. This stainless is non-magnetic therefore it will not work in flatware retrievers.

## 18/0 Stainless Steel *(420 Stainless)*

Contains 18% chromium and 0% nickel. 18/0 has an economic value which is usually seen at casual and high volume restaurants. This stainless steel is magnetic, therefore, it will work in flatware retrievers

## 13/0 Stainless Steel *(410 Stainless)*

Contains 13% chromium and 0% nickel. This steel is used to make knives due to the softer properties.

## Medium Weight

Medium weight flatware are patterns that are more economical and tend to be trendy and transitional. These patterns are ideal in casual, high-paced establishments as well as mid-level restaurants.

## Heavy Weight

Heavy weight flatware are upscale patterns that can be found in high-end restaurants, upscale casual and fine dining and in hotels. They tend to be more modern in design.





C&S  
Chef & Sommelier  
- FRANCE -

Made of the finest quality 18/10 heavy weight stainless steel, the Chef & Sommelier flatware collections are the final touch of elegance for a high end restaurant table.

The brand's range of cutlery is extremely resistant to corrosion, bending and twisting, and the wide range of designs allow it to meet the needs of different styles of establishments.



## *Black Oak 18/10*

Dark, bark-like handles that beautifully curve to meet refined heads.

- |                                               |                                            |
|-----------------------------------------------|--------------------------------------------|
| <b>FL901</b><br>Dinner Fork 8 ¼" 3 Dz.        | <b>FMO05</b><br>Dessert Fork 7 ¼" 3 Dz.    |
| <b>FL902</b><br>Dinner Spoon 8 ¾" 3 Dz.       | <b>FMO08</b><br>Dessert Knife 8 ½" 3 Dz.   |
| <b>FL904</b><br>Dinner Knife (SH) 9" 3 Dz.    | <b>FMO26</b><br>Steak Knife 9 ½" 3 Dz.     |
| <b>FL906</b><br>Dessert Spoon 7 ⅞" 3 Dz.      | <b>FMO12</b><br>Fish Fork 7 ¼" 3 Dz.       |
| <b>FL909</b><br>Soup Spoon 7" 3 Dz.           | <b>FL913</b><br>Fish Knife 8 ⅞" 3 Dz.      |
| <b>FL928</b><br>US Teaspoon 6 ⅞" 3 Dz.        | <b>FL940</b><br>Demitasse Spoon 4 ½" 3 Dz. |
| <b>FL929</b><br>Salad/Dessert Fork 7 ¼" 3 Dz. | <b>FL927</b><br>Butter Spreader 6 ⅝" 3 Dz. |



## *Black Oak Satin 18/10* NEW

The sleek satin look of this bark like design brings a modern twist to the trendy natural aesthetic.

- |                                               |
|-----------------------------------------------|
| <b>FN995</b><br>Dinner Fork 8 ⅞" 3 Dz.        |
| <b>FN996</b><br>Dinner Knife (SH) 9 ¾" 3 Dz.  |
| <b>FN997</b><br>Dessert Spoon 7 ¾" 3 Dz.      |
| <b>FN998</b><br>Salad/Dessert Fork 7 ½" 3 Dz. |
| <b>FP001</b><br>US Teaspoon 6 ⅞" 3 Dz.        |



Amuse/Tasting Spoon

## *Burlington 18/10*

Sophisticated, trendy, versatile Burlington creates a striking presentation for any table-scape.

### **EQ293**

Table Knife (SH) 9 ¼" 1 Dz.

### **EQ290**

Table Fork 8 ¼" 1 Dz.

### **EQ289**

Table/Serving Spoon 8 ½" 1 Dz.

### **EQ291**

Salad/Dessert Fork 7" 1 Dz.

### **EQ284**

Dessert/Oval Bowl Soup Spoon  
6 13/16" 1 Dz.

### **EQ285**

Round Bowl Soup Spoon 6 ¾" 1 Dz.

### **EQ283**

American Teaspoon 6" 1 Dz.

### **EQ287**

Coffee Spoon 5 ¾" 1 Dz.

### **EQ286**

Iced Teaspoon 8" 1 Dz.

### **EQ292**

Cocktail Fork 6" 1 Dz.

### **EQ294**

Butter Knife 6 ¾" 1 Dz.

### **EQ295**

Steak Knife (SH) 9" 1 Dz.

### **EQ288**

Amuse/Tasting Spoon 5 ¼" 1 Dz.

## *Diaz 18/10*

Flared handles are classic yet contemporary.

### **T5101**

Dinner Fork 8 ¼" 3 Dz.

### **T5102**

Dinner Spoon 8 ¼" 3 Dz.

### **T5104**

Dinner Knife (SH) 9 ¾" 3 Dz.

### **T5105**

Dessert Fork 7 ¼" 3 Dz.

### **T5106**

Dessert Spoon 7 ¼" 3 Dz.

### **T5109**

Soup Spoon 7" 3 Dz.

### **T5111**

Demitasse Spoon 4 ½" 3 Dz.

### **T5121**

Cocktail/Oyster Fork 5 7/8" 3 Dz.

### **T5127**

Butter Spreader 6 5/8" 3 Dz.

### **T5128**

US Teaspoon 6 ½" 3 Dz.

### **T5129**

Salad Fork 7 ¼" 3 Dz.





## Exxo 18/10

Angled handles add a fresh hint of jazz.

**T5201**  
Dinner Fork 8 ¼" 3 Dz.

**T5202**  
Dinner Spoon 8 ¼" 3 Dz.

**T5204**  
Dinner Knife (SH) 9 ¾" 3 Dz.

**T5206**  
Dessert Spoon 7 ¼" 3 Dz.

**T5209**  
Soup Spoon 7" 3 Dz.

**T5211**  
Demitasse Spoon 4 ½" 3 Dz.

**T5221**  
Cocktail/Oyster Fork 5 7/8" 3 Dz.

**T5227**  
Butter Spreader 6 5/8" 3 Dz.

**T5228**  
US Teaspoon 6 1/8" 3 Dz.

**T5229**  
Salad Fork 7 ¼" 3 Dz.



## Fluted 18/10

Fluted handles separated by bands at the bottom and neck create a traditional poised look.

**FL201**  
Dinner Fork 8 ½" 3 Dz.

**FL202**  
Dinner Spoon 8 5/8" 3 Dz.

**FL204**  
Dinner Knife (SH) 8 7/8" 3 Dz.

**FL206**  
Dessert Spoon 7 7/8" 3 Dz.

**FL209**  
Soup Spoon 7" 3 Dz.

**FL211**  
Demitasse Spoon 4 ½" 3 Dz.

**FL218**  
Iced Teaspoon 7" 3 Dz.

**FL221**  
Cocktail/Oyster Fork 5 ¾" 3 Dz.

**FL227**  
Butter Spreader 6 ½" 3 Dz.

**FL228**  
US Teaspoon 6 5/8" 3 Dz.

**FL229**  
Salad Fork 7 1/8" 3 Dz.



## Harper 18/10

Squared and flared. Subtle impressions give handles a natural appeal.

**FL701**

Dinner Fork 8 1/8" 3 Dz.

**FL702**

Dinner Spoon 8 1/2" 3 Dz.

**FL704**

Dinner Knife (SH) 9 1/2" 3 Dz.

**FL706**

Dessert Spoon 7 1/2" 3 Dz.

**FL709**

Soup Spoon 7 3/8" 3 Dz.

**FL711**

Demitasse Spoon 4 3/4" 3 Dz.

**FL718**

Iced Teaspoon 7 1/4" 3 Dz.

**FL721**

Cocktail/Oyster Fork 5 5/8" 3 Dz.

**FL727**

Butter Spreader 6 3/8" 3 Dz.

**FL728**

US Teaspoon 6 3/4" 3 Dz.

**FL729**

Salad Fork 7 3/8" 3 Dz.



## Harper Satin 18/10 NEW

Satin adds a touch of elegance to this modern squared pattern. Harper is an ideal pattern for hotels as well as trendy upscale restaurants.

**FN688**

Dinner Fork 8 1/8" 3 Dz.

**FN689**

Dinner Knife (SH) 9 1/2" 3 Dz.

**FN690**

Dinner Spoon 8 1/2" 3 Dz.

**FN692**

Salad Fork 7 3/8" 3 Dz.

**FN695**

US Teaspoon 7 1/4" 3 Dz.

**FN694**

Soup Spoon 7 1/8" 3 Dz.

**FN681**

Butter Spreader 6 3/8" 3 Dz.

**FN685**

Cocktail Fork 5 5/8" 3 Dz.

**FN686**

Demitasse Spoon 4 3/4" 3 Dz.

**FN687**

Dessert Spoon 7 1/2" 3 Dz.

## *Knox 18/10*

Rounded heads with a hearty, hammered texture embellish the handles and discreetly hides fingerprints.

**FK801**  
Dinner Fork 8 ½" 3 Dz.

**FK802**  
Dinner Spoon 8 ¾" 3 Dz.

**FK804**  
Dinner Knife (SH) 9 ½" 3 Dz.

**FK806**  
Dessert Spoon 7 ⅞" 3 Dz.

**FK809**  
Soup Spoon 7 ¼" 3 Dz.

**FK828**  
US Teaspoon 7 ⅜" 3 Dz.

**FK829**  
Salad/Dessert Fork 7 ½" 3 Dz.



## *Kya 18/10*

Subtle curves create understated elegance.

**T5401**  
Dinner Fork 8 ⅞" 3 Dz.

**T5402**  
Dinner Spoon 8 ⅜" 3 Dz.

**T5404**  
Dinner Knife (SH) 9 ⅜" 3 Dz.

**T5405**  
Dessert Fork 7 ⅜" 3 Dz.

**T5406**  
Dessert Spoon 7 ⅜" 3 Dz.

**T5408**  
Dessert Knife (SH) 8 ¼" 3 Dz.

**T5409**  
Soup Spoon 7" 3 Dz.

**T5410**  
Euro Teaspoon 5 ½" 3 Dz.

**T5411**  
Demitasse Spoon 4 ½" 3 Dz.

**T5427**  
Butter Spreader 6 ⅝" 3 Dz.

**T5428**  
US Teaspoon 6 ⅞" 3 Dz.

**T5429**  
Salad Fork 7 ½" 3 Dz.



## *Kya Sand 18/10*

A unique two-tone extension to our popular Kya collection featuring a mirror finish top and subtle sand handle for exceptional elegance and style.

**FJ701**

Dinner Fork 8 1/8" 3 Dz.

**FJ704**

Dinner Knife (SH) 9 3/8" 3 Dz.

**FJ706**

Dessert Spoon 7 3/8" 3 Dz.

**FJ708**

US Teaspoon 6 1/8" 3 Dz.

**FJ709**

Salad Fork 7 1/2" 3 Dz.

**FG727**

Butter Spreader 6 1/2" 3 Dz.



## *Lazzo 18/10*

Gentle curves. Graceful tapers.  
Essential and timeless.

**T4701**

Dinner Fork 8 1/4" 3 Dz.

**T4702**

Dinner Spoon 8 1/4" 3 Dz.

**T4704**

Dinner Knife (SH) 9 1/2" 3 Dz.

**T4706**

Dessert Spoon 7 1/4" 3 Dz.

**T4709**

Soup Spoon 6 7/8" 3 Dz.

**T4711**

Demitasse Spoon 4 1/2" 3 Dz.

**T4728**

US Teaspoon 6" 3 Dz.

**T4729**

Salad Fork 7 1/4" 3 Dz.

**T0426**

Steak Knife (SH) 9 1/2" 3 Dz.

**T4727**

Butter Spreader 6 1/2" 3 Dz.

**T0418**

Iced Tea Spoon 7 1/8" 3 Dz.





**Liv II 18/10** NEW

This classic square tapered design offers a timeless look to the most eclectic designs and atmospheres. Heavyweight and made of the highest quality 18/10 stainless steel is sure to withstand the busiest establishments.

**FP117**  
Dinner Fork 8" 1 Dz.

**FP119**  
Dinner Knife (SH) 9 1/2" 1 Dz.

**FP120**  
Dessert Spoon 7 7/8" 1 Dz.

**FP121**  
Butter Knife 6 1/2" 1 Dz.

**FP122**  
Dessert/Salad Fork 6 7/8" 1 Dz.

**FP124**  
Teaspoon 6 1/2" 1 Dz.



**Orzon 18/10**

Classic with reeded trim and curved details.

**T4801**  
Dinner Fork 8 1/8" 3 Dz.

**T4802**  
Dinner Spoon 8 1/8" 3 Dz.

**T4804**  
Dinner Knife (SH) 9 5/8" 3 Dz.

**T4806**  
Dessert Spoon 7 1/8" 3 Dz.

**T4809**  
Soup Spoon 6 7/8" 3 Dz.

**T4811**  
Demitasse Spoon 4 3/8" 3 Dz.

**T4828**  
US Teaspoon 6" 3 Dz.

**T4829**  
Salad Fork 7 1/4" 3 Dz.





## *Orzon Patina 18/10*

The soft, grey, lustrous finish of Orzon Patina is created from a highly distressed tumbled process for a complete vintage look from blade to handle. Subtle handle designs create a classically cut pattern.

### **FK401**

Dinner Fork 8 1/8" 3 Dz.

### **FK404**

Dinner Knife (SH) 9 5/8" 3 Dz.

### **FK406**

Dessert Spoon 7 1/8" 3 Dz.

### **FK428**

US Teaspoon 6" 3 Dz.

### **FK429**

Salad Fork 7 1/4" 3 Dz.

## *Renzo 18/10*

Gentle ridges create perfect style and balance.

### **T4901**

Dinner Fork 8 1/8" 3 Dz.

### **T4902**

Dinner Spoon 8 1/4" 3 Dz.

### **T4904**

Dinner Knife (SH) 9 5/8" 3 Dz.

### **T4905**

Dessert Fork 7 1/4" 3 Dz.

### **T4906**

Dessert Spoon 7 1/4" 3 Dz.

### **T4908**

Dessert Knife (SH) 8 3/8" 3 Dz.

### **T4909**

Soup Spoon 6 7/8" 3 Dz.

### **T4911**

Demitasse Spoon 4 1/2" 3 Dz.

### **T4918**

Iced Teaspoon 7 1/8" 3 Dz.

### **T4927**

Butter Spreader 6 1/2" 3 Dz.

### **T4928**

US Teaspoon 6" 3 Dz.

### **T4929**

Salad Fork 7 1/4" 3 Dz.





## *Renzo Patina 18/10*

Vintage inspired, our Renzo Patina collection features a rumbled, antique distressed appearance from a tumbled process that brings traditional charm to the table. A soft, rich and warm finish brings this unique artisan collection to life.

**FK501**

Dinner Fork 8 1/8" 3 Dz.

**FK504**

Dinner Knife (SH) 9 5/8" 3 Dz.

**FK506**

Dessert Spoon 7 1/4" 3 Dz.

**FM711**

Demitasse Spoon 4 1/2" 3 Dz.

**FM721**

Cocktail Fork 5 7/8" 3 Dz.

**FK528**

US Teaspoon 6" 3 Dz.

**FK529**

Salad/Dessert Fork 7 1/4" 3 Dz.





## Sola

For over 150 years, this Swiss cutlery manufacturer offers high quality flatware combined with trendy designs.

Made in 18/10 stainless steel, Sola collections offer unique patterns and finishes to allow each style of high-end establishments to find the one that best suits them.



## *Alessandria 18/10*

A classic beveled pattern with square handles are complementary to the trendy colors of today's table settings.

**MB202**

Table Knife (SH) 9 ¼" 1 Dz.

**MB201**

Table Fork 8" 1 Dz.

**MB204**

Dessert Fork 7 ⅜" 1 Dz.

**MB203**

Dessert Spoon 7 ⅜" 1 Dz.

**MB220**

American Teaspoon 6 ⅛" 1 Dz.

## *Baguette Black 18/10*

There's nothing traditional about this Baguette pattern. Black offers a bold statement for any table.

**MB247**  
Table Knife (SH) 9" 1 Dz.

**MB246**  
Table Fork 8 1/8" 1 Dz.

**MB251**  
Dessert Knife 8" 1 Dz.

**MB250**  
Dessert Fork 7 3/8" 1 Dz.

**MB249**  
Dessert Spoon 7 3/8" 1 Dz.

**MB253**  
American Teaspoon 6" 1 Dz.

**MB248**  
Teaspoon 5 3/4" 1 Dz.

**MB252**  
Coffee Spoon 4 1/2" 1 Dz.

**MB254**  
Cake Fork 5 3/4" 1 Dz.



## *Baguette Copper 18/10*

There's nothing traditional about this Baguette pattern. Copper offers a trendy and unique presentation.

**FM571**  
Table Knife (SH) 9" 1 Dz.

**FM575**  
Table Fork 8 1/8" 1 Dz.

**FM577**  
Tablespoon 8 1/8" 1 Dz.

**FM578**  
Dessert Knife 8" 1 Dz.

**FM579**  
Dessert Fork 7 3/8" 1 Dz.

**FM580**  
Dessert Spoon 7 3/8" 1 Dz.

**FM581**  
American Teaspoon 6" 1 Dz.

**FM582**  
Teaspoon 5 3/4" 1 Dz.

**FM583**  
Coffee Spoon 4 1/2" 1 Dz.

**FM584**  
Cake Fork 5 3/4" 1 Dz.

## *Baguette Vintage Stone Wash 18/10*

There is nothing traditional about this Baguette pattern. Rustic is this pattern's middle name. Ideal for a hand crafted look and feel.

**FL941**  
Table Knife (SH) 9" 1 Dz.

**FL942**  
Table Fork 8 1/8" 1 Dz.

**FL946**  
Tablespoon 8 1/8" 1 Dz.

**FL948**  
Dessert Fork 7 3/8" 1 Dz.

**FL951**  
Dessert Spoon 7 3/8" 1 Dz.

**FL953**  
American Teaspoon 6" 1 Dz.

**FL952**  
Teaspoon 5 3/4" 1 Dz.



## *Imperial Chopsticks*

These sleek chop sticks are the perfect accompaniment for any Asian flair cuisine. The square handles make handling easy.

**SCP99**  
Imperial Chop Sticks 8 3/4" 1 Dz.

**SCR98**  
Universal Chop Stick/ Knife Rest 2 3/4" 1 Dz.



## *Living Mirror 18/10*

Sleek contemporary handles make a dramatic statement for a variety of table settings.

**MB298**

Table Knife (SH) 9" 1 Dz.

**MB297**

Table Fork 8 1/8" 1 Dz.

**MB296**

Tablespoon 8 1/8" 1 Dz.

**MB301**

Dessert Knife 8" 1 Dz.

**MB300**

Dessert Fork 7 3/8" 1 Dz.

**MB299**

Dessert Spoon 7 3/8" 1 Dz.

**MB312**

Soup Spoon 7 1/8" 1 Dz.

**MB321**

American Teaspoon 6 1/2" 1 Dz.

**MB302**

Teaspoon 5 1/2" 1 Dz.

**MB303**

Coffee Spoon 4 3/8" 1 Dz.

**MB311**

Fish Knife 8 1/8" 1 Dz.



## *Living Satin 18/10*

Classic satin touch to the contemporary mirror adds flair to the modern shape.

**MB324**

Table Knife (SH) 9" 1 Dz.

**MB323**

Table Fork 8 1/8" 1 Dz.

**MB322**

Tablespoon 8 1/8" 1 Dz.

**MB327**

Dessert Fork 7 3/8" 1 Dz.

**MB326**

Dessert Spoon 7 3/8" 1 Dz.

**MB337**

Soup Spoon 7 1/8" 1 Dz.

**MB341**

American Teaspoon 6 1/2" 1 Dz.

**MB329**

Coffee Spoon 4 3/8" 1 Dz.

**MB331**

Fish Knife 8 1/8" 1 Dz.



## Luxus Sand 18/10

The elegant sand touch at the bottom of the handle is a unique design on this stylish pattern.

**SOL04**  
Table Knife (SH) 9 1/16" 1 Dz.

**SOL01**  
Table Fork 8 3/16" 1 Dz.

**SOL02**  
Tablespoon 8 3/16" 1 Dz.

**SOL08**  
Dessert Knife 8" 1 Dz.

**SOL05**  
Dessert Fork 7 5/16" 1 Dz.

**SOL06**  
Dessert Spoon 7 5/16" 1 Dz.

**SOL28**  
American Teaspoon 5 1/4" 1 Dz.

**SOL10**  
Teaspoon 5 1/12" 1 Dz.

**SOL11**  
Coffee Spoon 4 5/16" 1 Dz.

**SOL20**  
Cake Fork 6 7/16" 1 Dz.

**SOL13**  
Fish Knife 8 1/8" 1 Dz.



## Miracle 18/10

The honeycomb design hides all imperfections but not the perfect style of this pattern.

**SOM04**  
Table Knife (SH) 9 3/16" 1 Dz.

**SOM01**  
Table Fork 8 3/16" 1 Dz.

**SOM02**  
Tablespoon 8" 1 Dz.

**SOM05**  
Dessert Fork 7 1/4" 1 Dz.

**SOM06**  
Dessert Spoon 7 7/16" 1 Dz.

**SOM28**  
American Teaspoon 6 1/16" 1 Dz.

**SOM10**  
Teaspoon 5 13/16" 1 Dz.





**abert**

SINCE 1929, Abert has distinguished itself with its ability to interpret the market as well as their sustainable practices.

A symbol of quality and excellence, this MADE-IN-ITALY flatware is innovative and trendy!



## *Elegant 18/10* NEW

Geometric and harmonious lines for elegant and refined cutlery, appropriate for all occasions.

**FP494**  
Dinner Fork 8 3/16" 1 Dz.

**FP495**  
Dinner Knife (SH) 9 1/2" 1 Dz.

**FP499**  
Dessert Spoon 7 1/4" 1 Dz.

**FP501**  
Salad/Dessert Fork 7 1/4" 1 Dz.

**FP502**  
Teaspoon 5 1/2" 1 Dz.

**FP504**  
Soup Spoon 7 1/4" 1 Dz.

**FP652**  
Mocca Spoon 4 1/2" 1 Dz.

**FP653**  
Butter Knife 7" 1 Dz.



## *Enrico VIII 18/10* NEW

The refined decoration of the edge makes it the right pattern for elegant tables that rely on classical accessories to enhance their own aesthetic.

**FP535**  
Dinner Fork 8" 1 Dz.

**FP536**  
Dinner Knife (SH) 9 1/4" 1 Dz.

**FP537**  
Dessert Spoon 7 5/16" 1 Dz.

**FP538**  
Salad/Dessert Fork 7 1/4" 1 Dz.

**FP539**  
Teaspoon 5 3/8" 1 Dz.

**FP540**  
Dinner Spoon 8" 1 Dz.

**FP541**  
Soup Spoon 6 5/8" 1 Dz.

**FP542**  
Mocca Spoon 4 3/4" 1 Dz.

**FP664**  
Fish Fork 7 1/4" 1 Dz.

**FP665**  
Fish Knife 7 1/2" 1 Dz.

## *Matisse 18/10* NEW

A cutlery model with simple and soft features, for a fashionable and elegant table setting.

**FP474**

Dinner Fork 8 1/16" 1 Dz.

**FP475**

Dinner Knife (SH) 9 3/8" 1 Dz.

**FP477**

Dessert Spoon 7" 1 Dz.

**FP478**

Salad/Dessert Fork 7" 1 Dz.

**FP479**

Teaspoon 5 3/8" 1 Dz.

**FP480**

Soup Spoon 6 13/16" 1 Dz.

**FP642**

Mocca Spoon 4 1/2" 1 Dz.

**FP643**

Fish Fork 8" 1 Dz.

**FP644**

Fish Knife 8 1/4" 1 Dz.

**FP645**

Iced Tea Spoon 8 1/4" 1 Dz.

**FP646**

Butter Spreader 7" 1 Dz.



## *Matisse Vintage 18/10* NEW

A cutlery model with simple and soft features in an antique finish for a fashionable and elegant table setting.

**FP481**

Dinner Fork 8 1/16" 1 Dz.

**FP482**

Dinner Knife (SH) 9 3/8" 1 Dz.

**FP483**

Dessert Spoon 7" 1 Dz.

**FP484**

Salad/Dessert Fork 7" 1 Dz.

**FP485**

Teaspoon 5 3/8" 1 Dz.

**FP486**

Soup Spoon 6 13/16" 1 Dz.

**FP647**

Mocca Spoon 4 1/2" 1 Dz.

**FP648**

Butter Spreader 7" 1 Dz.



## Milord 18/10

NEW

Simple and smooth lines complement the most modern decor.

**FP558**

Dinner Fork 7 7/8" 1 Dz.

**FP559**

Dinner Knife (SH) 9 1/16" 1 Dz.

**FP560**

Dessert Spoon 7" 1 Dz.

**FP561**

Salad/Dessert Fork 7" 1 Dz.

**FP562**

Teaspoon 5 1/4" 1 Dz.

**FP564**

Soup Spoon 6 3/4" 1 Dz.

**FP563**

Dinner Spoon 7 7/8" 1 Dz.

**FP666**

Mocca Spoon 4 1/8" 1 Dz.

**FP667**

Iced Tea Spoon 7 3/8" 1 Dz.

**FP668**

Butter Spreader 6 1/2" 1 Dz.



## Neo 18/10

NEW

Wide and straight handles make a bold statement.

**FP565**

Dinner Fork 8 1/8" 1 Dz.

**FP566**

Dinner Knife (SH) 9 1/8" 1 Dz.

**FP567**

Dessert Spoon 7 1/2" 1 Dz.

**FP568**

Salad/Dessert Fork 7 1/2" 1 Dz.

**FP569**

Teaspoon 5 13/16" 1 Dz.

**FP570**

Dinner Spoon 8 1/4" 1 Dz.

**FP658**

Soup Spoon 7 7/8" 1 Dz.

**FP659**

Mocca Spoon 4 1/2" 1 Dz.

**FP660**

Butter Knife 6 7/8" 1 Dz.



## Rada 18/10 NEW

Classical and refined shapes with soft geometric decorations recall traditional values.

### FP523

Dinner Fork 8 1/8" 1 Dz.

### FP524

Dinner Knife (SH) 9 1/16" 1 Dz.

### FP526

Dessert Spoon 5 13/16" 1 Dz.

### FP528

Salad/Dessert Fork 7 3/8" 1 Dz.

### FP529

Teaspoon 5 1/2" 1 Dz.

### FP531

Dinner Spoon 8 3/16" 1 Dz.

### FP532

Soup Spoon 5 13/16" 1 Dz.

### FP533

Mocca Spoon 4 5/8" 1 Dz.

### FP534

Butter Spreader 6 7/8" 1 Dz.

### FP661

Fish Fork 7 1/4" 1 Dz.

### FP662

Fish Knife 8" 1 Dz.

### FP663

Iced Tea Spoon 5 1/2" 1 Dz.



## Rinascimento 18/10 NEW

This classic hammered pattern glistens and lights up the table bringing life to any setting.

### FP487

Dinner Fork 7 7/8" 1 Dz.

### FP488

Dinner Knife (SH) 9 1/4" 1 Dz.

### FP489

Dessert Spoon 6 15/16" 1 Dz.

### FP490

Salad/Dessert Fork 7 1/16" 1 Dz.

### FP491

Mocca Spoon 4 1/4" 1 Dz.

### FP492

Teaspoon 5 1/4" 1 Dz.

### FP493

Soup Spoon 6 1/16" 1 Dz.

### FP649

Fish Fork 7 1/2" 1 Dz.

### FP650

Fish Knife 8 1/4" 1 Dz.

### FP651

Butter Spreader 6 3/4" 1 Dz.

## Splendido 18/10 NEW

Traditional with a slight modern flair is the ideal complement for any establishment.

### FP543

Dinner Fork 7 7/8" 1 Dz.

### FP544

Dinner Knife (SH) 9 3/16" 1 Dz.

### FP545

Dessert Spoon 7 1/16" 1 Dz.

### FP546

Salad/Dessert Fork 7 1/16" 1 Dz.

### FP547

Teaspoon 5 1/2" 1 Dz.

### FP548

Dinner Spoon 7 15/16" 1 Dz.

### FP549

Soup Spoon 7" 1 Dz.

### FP550

Mocca Spoon 4 3/16" 1 Dz.

### FP669

Fish Fork 7 7/8" 1 Dz.

### FP670

Fish Knife 8 1/2" 1 Dz.

### FP671

Butter Spreader 6 3/4" 1 Dz.



## Stilo 18/10 NEW

A strong personality; tapered and rounded handles with a lance shaped knife blade. An unconventional pattern with great style.

**FP551**  
Dinner Fork 7 7/8" 1 Dz.

**FP552**  
Dinner Knife (SH) 9 5/16" 1 Dz.

**FP553**  
Dessert Spoon 7 1/16" 1 Dz.

**FP554**  
Salad/Dessert Fork 7 1/16" 1 Dz.

**FP555**  
Teaspoon 5 1/2" 1 Dz.

**FP556**  
Dinner Spoon 7 15/16" 1 Dz.

**FP557**  
Soup Spoon 7" 1 Dz.

**FP672**  
Mocca Spoon 4 1/3" 1 Dz.

**FP673**  
Butter Spreader 6 1/2" 1 Dz.



## Victory 18/10 NEW

An indisputable classic and timeless pattern for any decor.

**FP506**  
Dinner Fork 8 1/16" 1 Dz.

**FP507**  
Dinner Knife (SH) 9 1/16" 1 Dz.

**FP508**  
Dessert Spoon 7" 1 Dz.

**FP509**  
Salad/Dessert Fork 7 1/16" 1 Dz.

**FP576**  
Dessert Knife 8 3/16" 1 Dz.

**FP510**  
Teaspoon 5 3/8" 1 Dz.

**FP511**  
Dinner Spoon 8 1/16" 1 Dz.

**FP516**  
Soup Spoon 6 9/16" 1 Dz.

**FP517**  
Mocca Spoon 4 5/16" 1 Dz.

**FP519**  
Butter Spreader 6 1/16" 1 Dz.

**FP654**  
Fish Fork 8" 1 Dz.

**FP655**  
Fish Knife 8 1/4" 1 Dz.

**FP656**  
Iced Tea Spoon 8 1/8" 1 Dz.



## ARCOROC

Offering numerous collections, designs and solutions, Arcoroc flatware is enticing thanks to its good quality/price ratio.

All collections are made from 18/0 Stainless Steel.





## *Amber 18/0*

Sleek outlines surround sanded teardrop handles to create a chic, versatile look that hides fingerprints.

**FL601**  
Dinner Fork 7 7/8" 1 Dz.

**FL604**  
Dinner Knife (SH) 9" 1 Dz.

**FL606**  
Dessert Spoon 7 3/4" 1 Dz.

**FL609**  
Soup Spoon 7 1/8" 1 Dz.

**FL628**  
US Teaspoon 6 3/4" 1 Dz.

**FL629**  
Salad/Dessert Fork 7 1/8" 1 Dz.



## *Blake 18/0*

NEW

Exuding a contemporary and elegant aura, this forged Black PVD finish is poised to enhance both the ambiance and dining experience within any restaurant setting.

**FP322**  
Dinner Fork 7 13/16" 1 Dz.

**FP323**  
Dinner Knife (SH) 8 13/16" 1 Dz.

**FP326**  
Teaspoon 6 1/8" 1 Dz.

**FP324**  
Dessert Spoon 7 5/8" 1 Dz.

**FP325**  
Salad/Dessert Fork 6 7/8" 1 Dz.





## Capitale 18/0

Basic, essential and complete. The most common shapes and sizes at a value price point.

### FG701

Dinner Fork 8 ¼" 3 Dz.

### FG704

Dinner Knife (SH) 9 ⅜" 3 Dz.

### FG706

Dessert Spoon 7 ½" 3 Dz.

### FG709

Soup Spoon 6 ¼" 3 Dz.

### FG718

Iced Teaspoon 7 ½" 3 Dz.

### FG726

Steak Knife (SH) 9 ¼" 1 Dz.

### FG728

US Teaspoon 6 ⅞" 3 Dz.

### FG729

Salad/Dessert Fork 7 ½" 3 Dz.

## Greenwich 18/0

Sleek softly curved heads with squared ends and narrow handles in a polished, modernly casual design.

### FL501

Dinner Fork 7 ⅞" 1 Dz.

### FL502

Dinner Spoon 8" 1 Dz.

### FL504

Dinner Knife (SH) 9" 1 Dz.

### FL506

Dessert Spoon 7 ½" 1 Dz.

### FL509

Soup Spoon 6 ½" 1 Dz.

### FL518

Iced Teaspoon 7 ¼" 1 Dz.

### FL528

US Teaspoon 6 ¾" 1 Dz.

### FL529

Salad/Dessert Fork 6 ⅞" 1 Dz.



## Harrison 18/0

Simple yet classic rim pattern is ideal for any casual environment. Coordinates with a multitude of decors and withstands the rigors of fast paced establishments.

**FM501**  
Dinner Fork 7 7/8" 1 Dz.

**FM502**  
Dinner Spoon 8 3/8" 1 Dz.

**FM504**  
Dinner Knife (SH) 9 1/8" 1 Dz.

**FM506**  
Dessert Spoon 7 1/8" 1 Dz.

**FM509**  
Soup Spoon 6 7/8" 1 Dz.

**FM529**  
Salad/Dessert Fork 6 3/8" 1 Dz.

**FM505**  
US Salad Fork 7 3/16" 1 Dz.

**FM528**  
US Teaspoon 6 1/8" 1 Dz.

**FM518**  
Iced Teaspoon 7 1/2" 1 Dz.

**FM530**  
Euro Dinner Fork 8 3/8" 1 Dz.



## Latham 18/0

These arcs get high marks for comfort and style.

**T3601**  
Dinner Fork 8 1/4" 1 Dz.

**T3602**  
Dinner Spoon 8 1/4" 1 Dz.

**T3604**  
Dinner Knife (SH) 9 1/4" 1 Dz.

**T3606**  
Dessert Spoon 7" 1 Dz.

**T3611**  
Demitasse Spoon 4 3/8" 1 Dz.

**T3621**  
Oyster/Cocktail Fork 6" 1 Dz.

**T3627**  
Butter Spreader 7" 1 Dz.

**T3628**  
US Teaspoon 6" 1 Dz.

**T3629**  
Salad Fork 7" 1 Dz.



## *Latham Sand 18/0*

These arcs get high marks for comfort and style with a two tone finish.

**FJ801**  
Dinner Fork 8 ¼" 1 Dz.

**FJ804**  
Dinner Knife (SH) 9 ¼" 1 Dz.

**FJ806**  
Dessert Spoon 7" 1 Dz.

**FJ909**  
Butter Spreader 7" 1 Dz.

**FJ911**  
Demitasse Spoon 4 ¾" 4 Dz.

**FJ828**  
US Teaspoon 6" 1 Dz.

**FJ829**  
Salad Fork 7" 1 Dz.

## *Liv 18/0*

A sharp square, straight line tapered handle in a classic design.

**FL401**  
Dinner Fork 8" 1 Dz.

**FL402**  
Dinner Spoon 8" 1 Dz.

**FL404**  
Dinner Knife (SH) 9 ½" 1 Dz.

**FL406**  
Dessert Spoon 7 ⅞" 1 Dz.

**FL409**  
Soup Spoon 7" 1 Dz.

**FL418**  
Iced Teaspoon 6 ⅞" 1 Dz.

**FL428**  
US Teaspoon 6 ½" 1 Dz.

**FL429**  
Salad/Dessert Fork 6 ⅞" 1 Dz.



NEW

## *Liv Gunmetal 18/0*

Updating our popular Liv pattern in a smokey modern gunmetal finish will bring a classic look with a modern flair to the table.

**FP277**  
Dinner Fork 8" 1 Dz.

**FP278**  
Dinner Knife (SH) 9 1/2" 1 Dz.

**FP279**  
Dessert Spoon 7 7/8" 1 Dz.

**FP281**  
Teaspoon 6 1/2" 1 Dz.

**FP280**  
Salad/Dessert Fork 6 7/8" 1 Dz.



## *Matiz 18/0*

Rounded ends bring dining full circle.

**T1901**  
Dinner Fork 8" 1 Dz.

**T1902**  
Dinner Spoon 8" 1 Dz.

**T1904**  
Dinner Knife (SH) 9 1/4" 1 Dz.

**T1906**  
Dessert Spoon 7 1/8" 1 Dz.

**T1911**  
Demitasse Spoon 4 3/8" 1 Dz.

**T1928**  
US Teaspoon 6" 1 Dz.

**T1929**  
Salad Fork 7" 1 Dz.





## *Mikayla 18/0*

Contemporary pieces of art that have bold yet discreet etched handles that mask fingerprint smudges.

**FL101**  
Dinner Fork 8 ¼" 1 Dz.

**FL104**  
Dinner Knife (SH) 9" 1 Dz.

**FL106**  
Dessert Spoon 7 ⅞" 1 Dz.

**FL109**  
Soup Spoon 6 ⅞" 1 Dz.

**FL118**  
Iced Teaspoon 7" 1 Dz.

**FL128**  
US Teaspoon 6 ⅞" 1 Dz.

**FL129**  
Salad/Dessert Fork 7 ⅞" 1 Dz.

## *Satineo 18/0*

Smooth lines in a subtle satin finish.

**T7801**  
Dinner Fork 8 ¼" 4 Dz.

**T7802**  
Dinner Spoon 8 ¼" 4 Dz.

**T7804**  
Dinner Knife (SH) 9 ⅜" 4 Dz.

**T7806**  
Dessert Spoon 7 ¼" 4 Dz.

**T7828**  
US Teaspoon 5 ⅞" 4 Dz.

**T7829**  
Salad Fork 7 ⅞" 4 Dz.





## *Stone 18/0*

The hammered texture, medium weight and feel is the perfect complement to dress up your tabletop.

**T8001**  
Dinner Fork 8" 1 Dz.

**T8002**  
Dinner Spoon 8 1/8" 1 Dz.

**T8004**  
Dinner Knife (SH) 9 1/2" 1 Dz.

**T8006**  
Dessert Spoon 7" 1 Dz.

**T8008**  
Dessert Knife (SH) 8 7/8" 1 Dz.

**T8009**  
Soup Spoon 6 7/8" 1 Dz.

**T8011**  
Demitasse Spoon 4 3/8" 1 Dz.

**T8018**  
Iced Teaspoon 7 3/4" 1 Dz.

**T8028**  
US Teaspoon 6" 1 Dz.

**T8029**  
Salad Fork 6 7/8" 1 Dz.





## *Stone Satin 18/0*

Our Stone flatware, with a satin finish. Ideal choice for everyday use with lustrous designs.

**FM601**

Dinner Fork 8" 1 Dz.

**FM604**

Dinner Knife (SH) 9 ½" 1 Dz.

**FM606**

Dessert Spoon 7" 1 Dz.

**FM609**

Soup Spoon 6 ⅞" 1 Dz.

**FM611**

Demitasse Spoon 4 ¾" 1 Dz.

**FM627**

Butter Spreader 6" 1 Dz.

**FM628**

US Teaspoon 6" 1 Dz.

**FM629**

Salad Fork 6 ⅞" 1 Dz.





## *Vesca 18/0*

Simple and straightforward has never seemed so fresh.

**T1801**

Dinner Fork 8" 1 Dz.

**T1802**

Dinner Spoon 8" 1 Dz.

**T1804**

Dinner Knife (SH) 9 ¼" 1 Dz.

**T1805**

Dessert Fork 7 ½" 1 Dz.

**T1806**

Dessert Spoon 7 ½" 1 Dz.

**T1808**

Dessert Knife (SH) 8 ½" 1 Dz.

**T1809**

Soup Spoon 6 7/8" 1 Dz.

**T1811**

Demitasse Spoon 4 3/8" 1 Dz.

**T1828**

US Teaspoon 6" 1 Dz.

**T1829**

Salad Fork 7" 1 Dz.

Shown Marble Black Steak Knife





# *STEAK KNIVES*



## **PAKKAWOOD**

An engineered wood/plastic composite material. It creates a genuine wood grain look with better durability and no warping or splitting which is common in real wood.



## **ACRYLIC**

A transparent thermoplastic homopolymer that is dishwasher safe and great for high abrasion resistance.



## **POM**

An engineered thermoplastic material for steak knife handles. A typical application for injection-molded designs.

# Steak Knives



**FJ611**  
Regal Steak Knife (Rounded Tip)  
Pakkawood  
9 3/8" 1 Dz.



**FK307**  
Ellitte Steak Knife (Rounded Tip)  
Pakkawood  
10 7/8" 1 Dz.



**FJ612**  
Regal Steak Knife (Pointed Tip)  
Pakkawood  
9 3/8" 1 Dz.



**FJ507**  
Imperial Steak Knife (Brown/Black)  
Pakkawood  
9 5/8" 1 Dz.



**FK603**  
Regal Steak Knife - Grey (Pointed Tip)  
Pakkawood  
9 3/8" 1 Dz.



**FJ506**  
Imperial Steak Knife (Grey)  
Pakkawood  
9 5/8" 1 Dz.



**FJ508**  
Royale Steak Knife (Cherry)  
Pakkawood  
9" 1 Dz.



**FP167**  
Marble Black Steak Knife, Serrated  
Acrylic  
9 ¼" 1 Dz.



**FMO06**  
Marble Steak Knife, Serrated  
Acrylic  
9 ¼" 1 Dz.



**FP168**  
Marble Black Steak Knife, Non-Serrated  
Acrylic  
9 ¼" 1 Dz.



**FN727**  
Marble Steak Knife, Non-Serrated  
Acrylic  
9 ¼" 1 Dz.



**FJ516**  
Imperial Steak Knife (Solid Black)  
Acrylic  
9 ⅝" 1 Dz.



**FP228**  
Imperial Steak Knife (Marble)  
Acrylic  
9 ⅝" 1 Dz.



**FJ517**  
Imperial Steak Knife (Solid Red)  
Acrylic  
9 ⅝" 1 Dz.



**ESK01**  
Chelsea Steak Knife  
POM  
10" 6 Pcs.



**FMO26**  
Black Oak Steak Knife  
9 ½" 3 Dz.



**T0426**  
Universal (Lazzo) Steak Knife (SH)  
9 ½" 3 Dz.



**EQ295**  
Burlington Steak Knife (SH)  
9" 1 Dz.



# Steak Knives

abert

NEW



**FP571**  
Angus Steak Knife, Riveted  
POM  
9" 6 Pcs.

NEW



**FP572**  
Texas Steak Knife, Razor Edge  
Pakkawood  
9 ¼" 6 Pcs.

NEW



**FP575**  
Modern Steak Knife, Serrated  
9" 1 Dz.

NEW



**FP574**  
Fiorentina Stainless Steak Knife  
9" 6 Pcs.

NEW



**FP573**  
Paleo Pizza Steak Knife  
9 ¼" 6 Pcs.



**ELG01**  
Beverly Steak Knife  
POM  
9" 6 Pcs.



**FG726**  
Capitale Steak Knife (HH)  
9" 6 Pcs.



**T1826**  
Vesca Steak Knife (SH)  
9 3/8" 1 Dz.



# *SERVING ACCESSORIES*





## *Lazzo 18/10*

Essential pieces feature Lazzo's timeless curves and tapered ends.



**T0417**  
Serving Spoon 10 1/8"  
3 Dz.



**T0422**  
Sauce Spoon 7 1/4"  
1 Dz.



**T0421**  
Oyster Fork 5 5/8"  
3 Dz.



**T4727**  
Butter Spreader 6 1/2"  
3 Dz.



**T0418**  
Iced Tea Spoon 7 1/8"  
3 Dz.



# Living Mirror 18/10

Sleek, specialty items that will complement any collection.



**MB304**  
Cake Fork 6 1/2"  
1 Dz.



**MB305**  
Iced Teaspoon 8 1/8"  
1 Dz.



**MB306**  
Salad Server Spoon 8 7/8"  
1 Dz.



**MB307**  
Salad Server Fork 8 5/8"  
1 Dz.



**MB319**  
Large Serving Fork 5 1/8"  
1 Dz.



**MB309**  
Cake Server 10 1/8"  
1 Dz.



**MB316**  
Large Iced Teaspoon 13 7/8"  
1 Dz.



**MB308**  
Soup Ladle (3 Oz.) 10 7/8"  
1 Dz.



**MB317**  
Large Serving Spoon 15"  
1 Dz.



**MB318**  
Large Slotted Spoon 15"  
1 Dz.



**MB320**  
Large Spaghetti Spoon 14 3/4"  
1 Dz.

# Vesca 18/0

ARCOROC

Essential serving pieces feature Vesca's simple straightforward design.



**T1817**  
Serving Spoon 10 1/8"  
1 Dz.



**T1822**  
Sauce Spoon 7 1/8"  
1 Dz.



**T1818**  
Iced Teaspoon 7"  
1 Dz.



**T1816**  
Serving Fork 10 1/8"  
1 Dz.



**T1820**  
Cake Fork 5 7/8"  
1 Dz.



**T1819**  
Escargot Fork 5 7/8"  
1 Dz.



**T1821**  
Oyster/Cocktail Fork 5 5/8"  
1 Dz.



**T1813**  
Fish Knife 7 7/8"  
1 Dz.



**T1824**  
Sauce Ladle 6 7/8" (1 Oz.)  
6 Pcs.



**T1825**  
Soup Ladle 10 7/8" (5 Oz.)  
6 Pcs.





# *Buffetware*

We are proud to partner with expert brands to extend our product offering beyond the table. Arc Cardinal's buffetware is a carefully curated collection designed to indulge and inspire. Thoughtful designs, made with the highest quality materials, make it possible to personalize the buffet according to the menu and style of the establishment.



The image shows two metal buffet bowls, one on the left and one on the right, each resting on a black metal stand. The bowls are filled with fresh salad, including green leafy vegetables, yellow bell peppers, and purple onions. The stands are simple, with three legs and a circular base. The background is a red brick wall. A white rectangular box is overlaid in the center, containing the 'abert' logo and a paragraph of text.

# abert

Abert Buffetware offers top quality Italian craftsmanship and innovation. Designed to mix and match and create infinite buffet possibilities. The high quality of materials and functional designs will support the daily use of professionals: easy to clean and store while resistant to daily wear and tear.



Domino	304
Domino Wood	306
Domino Accessories	308
Mix & Play	310
Cosmo <i>NEW</i>	311
Cosmo Dispensers	312
Cosmo Imperfetto	313
Cosmo On Stage	314
Arcoroc Accessories	314
Serving <i>NEW</i>	315

# Domino

Manufactured from powder coated steel which protects from rust and scratches, podiums add different height elevations to the buffet. Available in 3 colors: black, white and copper.

Perfectly Matches the Domino Wood frames. See tile options on page 299.







Domino Podium  
L: 15 3/4" W: 7 7/8" H: 3 1/2"  
1 Pc.

**FP034** White  
**FP032** Black  
**FP033** Copper

Fits: 2 Tiles



Domino Podium  
L: 15 3/4" W: 7 7/8" H: 7 7/8"  
1 Pc.

**FP037** White  
**FP035** Black  
**FP036** Copper

Fits: 2 Tiles

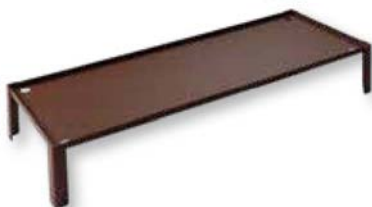

Domino Podium  
L: 23 5/8" W: 7 7/8" H: 3 1/2"  
1 Pc.

**FP040** White  
**FP038** Black  
**FP039** Copper

Fits: 3 Tiles



Domino Podium  
L: 23 5/8" W: 7 7/8" H: 7 7/8"  
1 Pc.

**FP043** White  
**FP041** Black  
**FP042** Copper

Fits: 3 Tiles



Domino Podium  
L: 15 3/4" W: 15 3/4" H: 3 1/2"  
1 Pc.

**FP046** White  
**FP044** Black  
**FP045** Copper

Fits: 4 Tiles



Domino Podium  
L: 23 5/8" W: 15 3/4" H: 3 1/2"  
1 Pc.

**FP049** White  
**FP047** Black  
**FP048** Copper

Fits: 6 Tiles



## *Domino Wood*

Domino frames are made in Ash wood, known for being a dense and durable wood featuring meandering grain patterns.

Each frame is stackable which is perfect for doubling up to add elevation on the buffet and for easy storage.

Perfectly Matches the Domino Steel frames. See tile options on page 299.

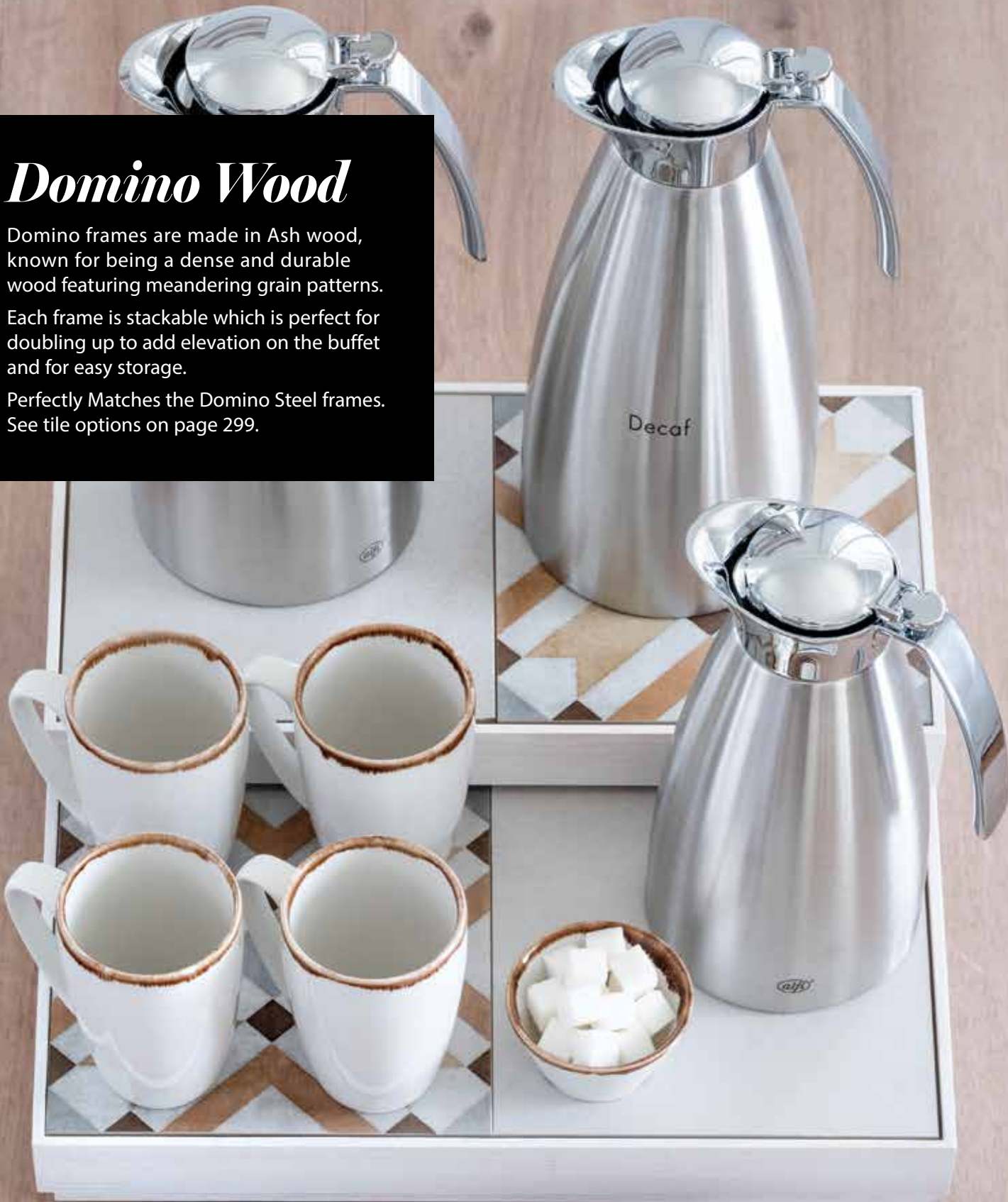



Domino Frame  
L: 15 3/4" W: 7 7/8" H: 2"  
1 Pc.

**FP021** White  
**FP022** Black

Fits: 2 Tiles or 3-Pitcher Stand



Domino Frame  
L: 23 5/8" W: 7 7/8" H: 2"  
1 Pc.

**FP023** White  
**FP024** Black

Fits: 3 Tiles, 1 Tile & 3-Pitcher Stand,  
or Ice Pack Holder & Cover



Domino Frame  
L: 15 3/4" W: 15 3/4" H: 2"  
1 Pc.

**FP025** White  
**FP026** Black

Fits: 4 Tiles or Combo of Tiles  
& 3-Pitcher Stand



Domino Frame  
L: 23 5/8" W: 15 3/4" H: 2"  
1 Pc.

**FP027** White  
**FP028** Black

Fits: 6 Tiles or Combo of Tiles  
& Ice Pack Holder & Cover or  
3-Pitcher Stand





Shown 3 Pitcher Stand, Fluid Carafes, Cosmos Domino Frame Black, Cosmo On Stage, Dudson Evo Collection

## *Domino Accessories*



**FP063**  
Domino Rectangular Ice Pack  
1 Pc.



**FP061**  
3 Pitcher Stand  
L: 15 3/4" W: 7 7/8"  
1 Pc.  
Fits: Domino Wood Frames



**FP060**  
Ice-Pack / Crumb Holder  
L: 23 5/8" W: 6 1/4"  
1 Pc.  
Fits: FP023, FP024, FP027, FP028



**FP058**  
Ice-Pack Cover Per Thermal Set  
L: 22" W: 6 1/4"  
1 Pc.

# Domino Tiles

Tiles from the Domino collection are made in vitrified porcelain; a material strong, resistant to wear and tear, light and water, oil and grease proof. Mix the various pattern tiles with Domino frames and Domino podiums to create a unique buffet.



**FP019**  
Domino Dark Grey Tile  
L: 7 7/8" W: 7 7/8"  
25 Pcs.

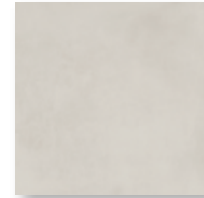

**FP018**  
Domino Light Grey Tile  
L: 7 7/8" W: 7 7/8"  
25 Pcs.



**FP012\***  
Domino Gray Mix Tile  
L: 7 7/8" W: 7 7/8"  
25 Pcs.



**FP017\***  
Domino Blue Mix Tile  
L: 7 7/8" W: 7 7/8"  
25 Pcs.



**FP020\***  
Domino Tan Mix Tile  
L: 7 7/8" W: 7 7/8"  
25 Pcs.



**FP016\***  
Domino Copper Mix Tile  
L: 7 7/8" W: 7 7/8"  
25 Pcs.

\*Tiles shown are an example of a set. Orders will be a mix of 25 tiles. Designs vary per color. To view more styles visit: [ArcCardinal.com](http://ArcCardinal.com)



# Mix & Play

Mix & Play ready-to-use sets are made from wood with a matte finish aluminum stand.

The 3 different structures can be combined together to offer an even larger buffet set.



**FP064**  
Revolution Set A  
L: 20 5/8" W: 27 1/2" H: 9 1/2"  
1 Pc.



**FP065**  
Revolution Set B  
L: 20 5/8" W: 27 1/2" H: 8 7/8"  
1 Pc.



**FP066**  
Revolution Set C  
L: 20 5/8" W: 27 1/2" H: 8 7/8"  
1 Pc.

# Cosmo

Modern style 18/10 stainless steel chafing dish that will perfectly match with the rest of the collections. Includes a durable black powder coated steel stand and a removable pan. Can be heated by chafing fuel or the electronic unit included.

With a fixed hinge top and an innovative evaporation system the chafing dish has a thin slot in the lid allowing steam to exit.



**FP057**  
Chafing Dish 2/3 GN with Black Support  
L: 16 1/4" W: 16" H: 10 1/4"  
1 Pc.



## Cosmo Induction Chafing Dish NEW

This round 18/10 stainless steel chafing dish will elevate and enhance the buffet presentation at your hotel, restaurant, or catered event. Perfect for keeping vegetables to entrees at ideal serving temperatures. It features a clear glass window that allows guests to see what's inside without having to open the lid. Compatible with induction heating elements, its induction bottom creates an excellent heating surface.



**FP381**  
Steel Round Chafing Dish 5 Qt. (160 Oz.)  
L: 13" H: 10"  
1 Pc.



**FP382**  
Copper Round Chafing Dish 5 Qt. (160 Oz.)  
L: 13" H: 10"  
1 Pc.



**FP383**  
Black Round Chafing Dish 5 Qt. (160 Oz.)  
L: 13" H: 10"  
1 Pc.

# Cosmo Dispensers

Unique by design and functionality, simple clean lines and effortless dispensing will complement any buffet.



**FP054**  
Juice Dispenser (8 L.)  
22"  
1 Pc.

Juice dispenser made in durable acrylic that offers an exceptional clarity and it can be use with or without the included ice pack to keep drinks cold.



**FP055**  
Coffee Urn (10 L.)  
20 1/8"  
1 Pc.

Heated by chafing fuel, the coffee urn made in stainless steel is easy to transport due to the two nobs on each side.



**FP056**  
Individual Cereal  
Dispenser (3 L.)  
20 7/8"  
1 Pc.

This cereal dispenser has a rubber paddle which dispenses a controlled portion of cereal or snacks.



**FP067**  
Jam/Honey Dispenser  
Base: 13 3/8" x 5" Max: 22 7/8"  
1 Pc.

The jam/honey dispenser can be use with the Jambee Nozzle (FP068 - sold separately) to infuse jam or honey into a croissant or muffin and has a disk inside the tube that cleans the walls of the dispenser.



**FP068**  
Jambee Nozzle 18/10  
L: 4 1/4"  
1 Pc.

Nozzle to be used with Jam & Honey Dispenser (FP067)



**FP062**  
Drip Tray W/ Grill 18/10  
L: 6 1/4" W: 6 1/4"  
1 Pc.

Optional magnetic drip tray sold separately can be use for the coffee urn and the juice dispenser.



# Cosmo Imperfetto

Platters that brings design to the buffet and allows a nice presentation of the food.



**FP051**  
Centerpiece Wood 18/10  
D: 12 1/4" H: 2 3/4"  
1 Pc.



**FP050**  
Centerpiece Wood 18/10  
D: 14 1/8" H: 1 5/8"  
1 Pc.



**FP052**  
Centerpiece Wood 18/10  
D: 14 1/8" H: 2 3/4"  
1 Pc.



**FP053**  
Centerpiece Wood 18/10  
D: 16 1/2" H: 2 3/4"  
1 Pc.

# Cosmo On Stage

On Stage stands made in powder coated stainless steel add elevation to the buffet. The stand can be used with the wood base or replace it with a salad bowl.



**FP029**  
Buffet Stand  
L: 11" W: 11" H: 7 7/8"  
1 Pc.



**FP030**  
Buffet Stand  
L: 11" W: 11" H: 9 7/8"  
1 Pc.



**FP031**  
Buffet Stand  
L: 11" W: 11" H: 11 3/4"  
1 Pc.



**FP059**  
Base Round, Matte Black  
W: 7 1/4"  
1 Pc.

**Arc Cardinal items that fit:**  
FH289 (Candour)  
R0947 (Vintage)  
N9362 (Evolutions)



PAIR WITH:

## Abert Accessories

Made in 18/10 stainless steel, this bowl is light, resistant and easy to clean. Elevate your buffet display by pairing the bowl with the Cosmos On Stage Stand or serve cold salads on the Domino cooling riser.



**FP274**  
Stainless Steel Serving Bowl  
(3 3/4 Qt. / 110 Oz.) 9 1/2"  
1 Pc.



**FP275**  
Stainless Steel Serving Bowl  
(5 1/4 Qt. / 174 Oz.) 11"  
1 Pc.

ARCOROC



# Serving NEW

Experience sophistication in your buffet spread with our collection of serving utensils made from high-quality stainless steel. Elevate your presentation with these sleek and durable tools, meticulously designed to bring both style and longevity to your dining buffet. Modern look and versatility will effortlessly enhance your serving experience.



**FP496**  
Pastry Scissor Tongs  
18/10 Stainless Steel  
8 ¼"  
1 Dz.



**FP497**  
Roast Scissor Tongs  
18/10 Stainless Steel  
9"  
1 Dz.



**FP498**  
Roast Tongs  
9"  
20 Pcs.



**FP500**  
Cake Tongs  
9"  
20 Pcs.



**FP503**  
Ice Tongs  
7 7/8"  
2 Dz.



**FP505**  
Salad Tongs  
10 ½"  
20 Pcs.





FRESH. HOT. COLD.

alfi® premium insulated carafes have set standards for the industry with its strict quality standards and award winning designs since 1914.



alfi® is a German brand that has been dedicated to making premium carafes for over 100 years. Add a perfect blend of function and elegance to any room.

alfi's European style sits perfectly with our Chef & Sommelier and Dudson designs.

Albergo	318
Gusto Top Therm	320
Hotello	322
Lightweight Carafe	324

# *Albergo*

Classical motif and modern technology;  
utilitarian and decorative design that  
demonstrates how seemingly contrasting  
elements can interact perfectly together.





**FN345/ AS2710SS2\***  
Albergo Top Therm 1.5 L (50 Oz.)  
L: 5 7/8" W: 7 1/2" H: 9 1/2"  
2 Pcs.



24 HOURS COLD



12 HOURS HOT



SPOUT SYSTEM  
CHROME PLATED PLASTIC

TOPTHERM VACUUM STAINLESS STEEL BODY

DURABLE STAINLESS STEEL  
INTERIOR AND EXTERIOR

# *Gusto Top Therm*

Gusto TT has an ultra-modern body that is seamlessly integrated within its ultra classic design. With its aesthetics and ergonomics in product design, Gusto has a new comfortable pouring system for easy pouring. Brush finish adds a touch of elegance and prevents finger-print markings.







**FN353/ AS2000SS2\***  
Gusto Top Therm 0.6 L (20 Oz.)  
L: 6 1/2" W: 4 1/2" H: 7 1/2"  
2 Pcs.



**FN352/ AS2010SS2\***  
Gusto Top Therm 1 L (34 Oz.)  
L: 4 9/16" W: 6 1/2" H: 8 1/2"  
2 Pcs.



**FN351/ AS2020SS2\***  
Gusto Top Therm 1.5 L (50 Oz.)  
L: 5 7/16" W: 6 3/8" H: 10 3/8"  
2 Pcs.



**FN354/ AS2020SS2COF\***  
Gusto Top Therm "COFFEE" Imprint  
1.5 L (50 Oz.)  
L: 5 7/16" W: 6 3/8" H: 10 3/8"  
2 Pcs.



**FN355/ AS2020SS2DEC\***  
Gusto Top Therm "DECAF" Imprint  
1.5 L (50 Oz.)  
L: 5 7/16" W: 6 3/8" H: 10 3/8"  
2 Pcs.



**FN356/ AS2020SS2HW\***  
Gusto Top Therm "HOT WATER" Imprint  
1.5 L (50 Oz.)  
L: 5 7/16" W: 6 3/8" H: 10 3/8"  
2 Pcs.



DISHWASHER SAFE



24 HOURS COLD



12 HOURS HOT



SPOUT SYSTEM  
CHROME PLATED PLASTIC

TOPTHERM VACUUM STAINLESS STEEL BODY

DURABLE STAINLESS STEEL  
INTERIOR AND EXTERIOR

# *Hotello*

The first of its kind to be designed specifically for the Hospitality industry.

The Hotello was designed with a completely unique sealing system that has no plastic or silicone parts.





**FN348/ AS2620SS2\***  
Hotello 1 L (34 Oz.)  
L: 4 9/10" W: 5 1/3" H: 8 3/25"  
2 Pcs.



16 HOURS COLD



8 HOURS HOT



DISHWASHER SAFE



SPECIALLY DEVELOPED HINGED LID  
WITH ONE HAND OPERATION

TOP THERM VACUUM STAINLESS STEEL BODY

DURABLE STAINLESS STEEL  
INTERIOR AND EXTERIOR

# *Lightweight Carafe*

Premium vacuum carafe in a sleek frosted black design adds elegance to beverage service.





COMFORTABLE SPOUT SYSTEM WITH ONE HAND OPERATION

ALFIDUR VACUUM HARD GLASS LINER

HIGH QUALITY PLASTIC WITH FROSTED SURFACE

**FN350/ AG2800BK2\***  
 Plastic Black Frosted Surface,  
 Vacuum Glass Insert 1 L (34 Oz.)  
 L: 5 3/8" W: 6 1/2" H: 10 1/2"  
 2 Pcs.



**TECHNOLOGY**

5 Layers For Improved Insulation:  
 Alfi 5 layer insulation technology that has silvering on both sides of its space between the glass layers and is equipped with a lasting vacuum. Therefore the carafe maintains the beverage temperature for longer.



24 HOURS COLD



12 HOURS HOT

\*alfi SKU, Use for Reference ONLY

ALFI is a registered trademark owned by Alfi GmbH IsoliergefäÙe, Metall- und Haushaltswaren in the U.S. and other countries.



THERMOS. TRUSTED SINCE 1904.

As the leading manufacturer of convenient insulated products for over 116 years, the Thermos® brand is trusted by food service professionals to provide innovative beverage servers that are high-performing and durable. All backed with NSF Certification.

THERMOS.



PERFORMANCE YOU CAN TRUST  
Thermos products deliver what matters everytime.

Brew In Carafe	328
Carafe With Gauge	330
Carafe With Lever	332
Twist And Pour	334
Accessories	336



NSF Certified - Meets Strict NSF Food and Product Safety Standards



Products are dishwasher safe.

# *Brew In Carafe*

Thermos professional Brew In Carafe  
with vacuum insulation technology  
for maximum temperature retention.



THERMOS.





● DIRECT BREW-IN STOPPER;  
FITS UNDER MOST BREWERS

● THERMOS™ VACUUM INSULATION  
TECHNOLOGY FOR MAXIMUM  
TEMPERATURE RETENTION

● DURABLE TYPE 304 STAINLESS STEEL  
INTERIOR AND EXTERIOR

**FN371/TGU1900SC6\***

NSF Cert. S.S. Brew In Vac. Carafe  
1.9 L (64 Oz.)  
L: 5" W: 5 3/16" H: 11 1/2"  
6 Pcs.



## REPLACEMENT ACCESSORIES



**FN441/ RTGSDC25\***  
Push Button Decaf Lid for  
FN371, FN370, FN357, FN369, FN372  
6 Pcs.



**FN444/ RTGUDC25\***  
Brew-In Decaf Lid for  
FN371, FN372, FN370, FN357, FN369  
6 Pcs.



**FN442/ RTGSG25\***  
Push Button Tea Lid for  
FN371, FN370, FN357, FN369, FN372  
6 Pcs.



**FN445/ RTGUG25\***  
Brew-In Tea Lid for  
FN371, FN372, FN370, FN357, FN369  
6 Pcs.



**FN443/ RTGSL25\***  
Push Button Coffee/ Hot Water Lid for  
FN371, FN370, FN357, FN369, FN372  
6 Pcs.



**FN446/ RTGUL25\***  
Brew-In Coffee/ Hot Water Lid for  
FN371, FN372, FN370, FN357, FN369  
6 Pcs.



\* Thermos SKU, Use for Reference ONLY

THERMOS is a registered trademark in over 115 countries.

# Carafe With Gauge

Brewer carafe with fresh zone stopper and gauge fits under most brewers. Thermos vacuum insulation technology for maximum temperature retention.



**FN372/ THF19SCLG4MD\***  
NSF Cert. S.S. Vac. Carafe with Gauge  
1.9 L (64 Oz.)  
L: 7" W: 8 1/2" H: 7 1/2"  
4 Pcs.

## REPLACEMENT ACCESSORIES



**FN441/ RTGSDC25\***  
Push Button Decaf Lid for  
FN370, FN357, FN369, FN372  
6 Pcs.



**FN444/ RTGUDC25\***  
Brew-In Decaf Lid for  
FN371, FN372, FN370, FN357, FN369  
6 Pcs.



**FN442/ RTGSG25\***  
Push Button Tea Lid for  
FN370, FN357, FN369, FN372  
6 Pcs.



**FN445/ RTGUG25\***  
Brew-In Tea Lid for  
FN371, FN372, FN370, FN357, FN369  
6 Pcs.



**FN443/ RTGSL25\***  
Push Button Coffee/ Hot Water Lid for  
FN370, FN357, FN369, FN372  
6 Pcs.



**FN446/ RTGUL25\***  
Brew-In Coffee/ Hot Water Lid for  
FN371, FN372, FN370, FN357, FN369  
6 Pcs.



**FN373/ THF0208\***  
Fresh Zone Stopper with Gauge  
with Care and Use and Brush for FN372  
10 Pcs.



DIRECT BREW-IN FRESH ZONE STOPPER; FITS UNDER MOST BREWERS

THE STOPPER FEATURES A CONVENIENT DIAL TO MARK THE BREWING TIME AND A VALVE TO TELL HOW FULL IS THE CARAFE

THERMOS™ VACUUM INSULATION TECHNOLOGY FOR MAXIMUM TEMPERATURE RETENTION

ERGONOMICALLY DESIGNED "OPEN HANDLE" FOR MANY POURING POSITIONS

LIGHTWEIGHT AND EASY TO CARRY

EXTERIOR STAYS COOL TO THE TOUCH WITH HOT CONTENTS AND SWEAT-PROOF WITH COLD

DURABLE TYPE 304 STAINLESS STEEL INTERIOR AND EXTERIOR



\* Thermos SKU, Use for Reference ONLY

THERMOS is a registered trademark in over 115 countries.

# *Carafe With Lever*

Designed for professional everyday use. Features a lever-operated stopper and a double wall stainless steel body to help keep coffee or tea at the perfect temperature.



- LEVER OPERATED ONE- PUSH STOPPER
- THERMOS™ VACUUM INSULATION TECHNOLOGY FOR MAXIMUM TEMPERATURE RETENTION
- FINGER PRINT RESISTANT CLEAR EXTERIOR FINISH
- DURABLE TYPE 304 STAINLESS STEEL INTERIOR AND EXTERIOR



**FN370/ TGS15SC\***  
NSF Cert. S.S. Push Button Vac. Carafe  
1.5 L (50 Oz.)  
L: 5" W: 6 3/8" H: 10"  
6 Pcs.

   
20 HOURS HOT    24 HOURS COLD



**FN357/ TGS10SC\***  
NSF Cert. S.S. Push Button Vac. Carafe  
1 L (34 Oz.)  
L: 5" W: 6 3/8" H: 7 7/8"  
6 Pcs.

   
14 HOURS HOT    24 HOURS COLD



**FN369/ TGS06SC\***  
NSF Cert. S.S. Push Button Vac. Carafe  
0.6 L (20 Oz.)  
L: 5" W: 6 3/8" H: 6 1/2"  
6 Pcs.

   
9 HOURS HOT    22 HOURS COLD

## REPLACEMENT ACCESSORIES



**FN441/ RTGSDC25\***  
Push Button Decaf Lid for  
FN370, FN357, FN369, FN372  
6 Pcs.



**FN444/ RTGUDC25\***  
Brew-In Decaf Lid for  
FN371, FN372, FN370, FN357, FN369  
6 Pcs.



**FN442/ RTGSG25\***  
Push Button Tea Lid for  
FN370, FN357, FN369, FN372  
6 Pcs.



**FN445/ RTGUG25\***  
Brew-In Tea Lid for  
FN371, FN372, FN370, FN357, FN369  
6 Pcs.



**FN443/ RTGSL25\***  
Push Button Coffee/ Hot Water Lid for  
FN370, FN357, FN369, FN372  
6 Pcs.



**FN446/ RTGUL25\***  
Brew-In Coffee/ Hot Water Lid for  
FN371, FN372, FN370, FN357, FN369  
6 Pcs.



\* Thermos SKU, Use for Reference ONLY

THERMOS is a registered trademark in over 115 countries.



# Twist And Pour

Allows for cold storage of dairy products\* and hot drinks by the coffee station. Sturdy ergonomic and lightweight designed handle for easy pouring. Double silicone gasket on lid minimizes spills and helps with temperature retention.

\*See Care & Use for Details



**FN361/TGB06SC\***  
 NSF Cert. S.S. Vac. Carafe Twist/Pour  
 0.6 L (20 Oz.)  
 L: 4" W: 5 1/2" H: 8 1/16"  
 6 Pcs.



16 HOURS  
HOT



24 HOURS  
COLD



**FN368/TGM10SC\***  
 NSF Cert. S.S. Vac. Carafe Twist/Pour  
 1 L (34 Oz.)  
 L: 4 1/8" W: 6 3/8" H: 10 3/8"  
 6 Pcs.



22 HOURS  
HOT



24 HOURS  
COLD



LID HAS DOUBLE SILICONE GASKET TO MINIMIZE SPILLS AND ASSISTS IN TEMPERATURE RETENTION

THERMOS™ VACUUM INSULATION TECHNOLOGY FOR MAXIMUM TEMPERATURE RETENTION

DURABLE TYPE 304 STAINLESS STEEL INTERIOR AND EXTERIOR



**FN363/TGB10SCHH6\***  
 NSF Cert. S.S. Vac. Carafe Twist/Pour  
 "HALF & HALF" Imprint  
 0.9 L (32 Oz.)  
 L: 4 ½" W: 5 ½" H: 11 ¾"  
 6 Pcs.



**FN364/TGB10SCCR6\***  
 NSF Cert. S.S. Vac. Carafe Twist/Pour  
 "CREAM" Imprint  
 0.9 L (32 Oz.)  
 L: 4 ½" W: 5 ½" H: 11 ¾"  
 6 Pcs.



**FN365/TGB10SCLF6\***  
 NSF Cert. S.S. Vac. Carafe Twist/Pour  
 "LOW FAT" Imprint  
 0.9 L (32 Oz.)  
 L: 4 ½" W: 5 ½" H: 11 ¾"  
 6 Pcs.



**FN366/TGB10SCML6\***  
 NSF Cert. S.S. Vac. Carafe Twist/Pour  
 "MILK" Imprint  
 0.9 L (32 Oz.)  
 L: 4 ½" W: 5 ½" H: 11 ¾"  
 6 Pcs.



**FN367/TGB10SCSK6\***  
 NSF Cert. S.S. Vac. Carafe Twist/Pour  
 "SKIM" Imprint  
 0.9 L (32 Oz.)  
 L: 4 ½" W: 5 ½" H: 11 ¾"  
 6 Pcs.



**FN362/TGB10SC\***  
 NSF Cert. S.S. Vac. Carafe Twist/Pour  
 0.9 L (32 Oz.)  
 L: 4 ½" W: 5 ½" H: 11 ¾"  
 6 Pcs.



24 HOURS  
HOT



24 HOURS  
COLD



\* Thermos SKU, Use for Reference ONLY

THERMOS is a registered trademark in over 115 countries.







**FN441/ RTGSDC25\***  
Push Button Decaf Lid for  
FN370, FN357, FN369, FN372  
6 Pcs.



**FN442/ RTGSG25\***  
Push Button Tea Lid for  
FN370, FN357, FN369, FN372  
6 Pcs.



**FN443/ RTGSL25\***  
Push Button Coffee/ Hot Water Lid  
for FN370, FN357, FN369, FN372  
6 Pcs.



**FN444/ RTGUDC25\***  
Brew-In Decaf Lid for  
FN371, FN372, FN370, FN357, FN369  
6 Pcs.



**FN445/ RTGUG25\***  
Brew-In Tea Lid for  
FN371, FN372, FN370, FN357, FN369  
6 Pcs.



**FN446/ RTGUL25\***  
Brew-In Coffee/ Hot Water Lid for  
FN371, FN372, FN370, FN357, FN369  
6 Pcs.



**FN447/ TGB900525\***  
Replacement TGB Stopper for  
FN361, FN363, FN364, FN365,  
FN366, FN367, FN362  
6 Pcs.



**FN448/ TGM1005125\***  
Replacement Stopper for FN368  
6 Pcs.



**FN373/ THF0208\***  
Fresh Zone Stopper with Gauge  
Care and Use and Brush for FN372  
10 Pcs.





# CHASSEUR®

PROUDLY HANDCRAFTED IN THE FRENCH ARDENNES.  
Rooted in the heart of the food and wine region of France, Chasseurs' cast iron cookware and serve ware is manufactured to the highest quality standards and favored by top chefs from around the world.



The Chasseur brand has obtained the "Guaranteed Made in France" certification; the only certification that guarantees that a product has been made in France.

Round & Oval Casserole	340
Round & Oval Low Casserole	342
Terrine Rectangle Gratin	344
Round & Oval Dish	346
Trivets	347

COMPATIBLE WITH ALL HEAT SOURCES



\*If using induction, heat slow. Do not use hot boost.

## *Round & Oval Casserole*

Cast iron is compatible with all heat sources including induction which makes the perfect presentation for any buffet. It makes a dramatic statement with its stylish look and trendy colors as well as retaining its heat while serving up favorite buffet items.





**Mini Round Casserole**  
0.37 Q (12 Oz.) 3 15/16" (10 cm)  
1 Pc.

**FN421** Matte Black  
**FN422** Red



**Mini Round Casserole**  
0.63 Q (20 Oz.) 4 3/4" (12 cm)  
1 Pc.

**FN423** Matte Black  
**FN424** Red



**Round Casserole**  
4.23 Q (135 Oz.) 9 1/2" (24 cm)  
1 Pc.

**FN425** Matte Black  
**FN426** Red  
**FN949** Quartz  
**FN950** Grey



**Round Casserole**  
6.44 Q (206 Oz.) 11" (28 cm)  
1 Pc.

**FN427** Matte Black  
**FN428** Red  
**FN951** Quartz  
**FN952** Grey



 Chasseur on your buffet: Lid can be propped up using the side handle.



CHASSEUR

CHASSEUR

# Round & Oval Low Casserole



The round and oval low casseroles are the ultimate multi-use pan. The stylish lidded casserole is perfect for creating one dish meals and the perfect vessels for sides such as risotto and roasted vegetables.



**FN437**  
Round Serving Matte Black Casserole  
1.8 Q (57.6 Oz.) 9 1/2" (24 cm)  
1 Pc.



**FN438**  
Round Serving Ruby Casserole  
1.8 Q (57.6 Oz.) 9 1/2" (24 cm)  
1 Pc.



**FN432**  
Oval Matte Black Casserole  
4.23 Q (135.25 Oz.) 10 5/8" (27 cm)  
1 Pc.



**FN433**  
Oval Ruby Casserole  
4.23 Q (135.25 Oz.) 10 5/8" (27 cm)  
1 Pc.



**FN431**  
Oval Matte Black Casserole  
6.34 Q (202.88 Oz.) 12 1/4" (31 cm)  
1 Pc.



## *Terrine, Rectangle & Gratin*

The rectangular and gratin dishes make perfect casseroles and lasagnas. This multi-use item can serve as trendy vessels to serve desserts in like creme brulee. The two terrine sizes are not only essential for slowly cooking patés but make great pans for meatloafs and small casseroles.







**FN429**  
Rectangular Matte Black Terrine  
1.06 Q (34 Oz.)  
In: 9 7/8" x 3 3/8" (25 cm)  
Out: 12 1/4" x 4 3/8"  
1 Pc.



**FN430**  
Rectangular Matte Black Terrine  
1.25 Q (40.5 Oz.)  
In: 11 3/8" x 3 3/16" (27 cm)  
Out: 13 7/8" x 4 1/4"  
1 Pc.



**FN435**  
Rectangular Matte Black Baking Dish  
0.75 Q (23.66 Oz.)  
In: 8 7/8" x 5 1/8" (22 1/2 cm)  
Out: 10 3/4" x 5 1/2"  
1 Pc.



**FN436**  
Gratin Matte Black Baking Dish  
2.12 Q (68 Oz.)  
In: 11 1/2" x 8" (29 cm)  
Out: 12 13/16" x 8 1/4"  
1 Pc.



**FN434**  
Gratin Matte Black Baking Dish  
0.95 Q (30.5 Oz.)  
In: 7 1/2" x 4 1/16" (18 1/2 cm)  
Out: 9 1/8" x 4 15/16"  
1 Pc.



## *Round & Oval Dish*

Enameled cast iron is perfect for sautéing, roasting and stewing – it warms gradually, heats evenly and retains heat for a long time.





**FN417**  
Round Matte Black Dish (17 Oz.)  
In: 5 7/8" (15 cm) Out: 7 3/16"  
1 Pc.



**FN418**  
Round Matte Black Dish (24 Oz.)  
In: 6 3/4" (18 cm) Out: 8 1/2"  
1 Pc.



**FN419**  
Oval Matte Black Dish (17 Oz.)  
In: 7 7/8" x 5 3/4" (20 cm)  
Out: 10" x 5 7/8"  
1 Pc.



**FN420**  
Oval Matte Black Dish (12 Oz.)  
In: 11" x 7 7/8" (28 cm)  
Out: 13 3/8" x 8 1/8"  
1 Pc.



PAIR WITH: *Trivets* **NEW**

See Page 358 for more products that fit Trivets



**FN976**  
Round Trivet 8 1/2"  
6 Pcs.  
Fits: FN421, FN422,  
FN423, FN424



**FN977**  
Oval Trivet  
L: 10 1/2" W: 8"  
6 Pcs.  
Fits: FN417, FN418



**FN978**  
Oval Trivet  
L: 11 3/4" W: 7"  
6 Pcs.  
Fits: FN419

ARCOROC





Shown Tempo Lamp White



*Accessories*



# abert

Abert offers a new selection of table accessories designed to create a unique and elevated experience. From table lamps to champagne buckets to serving trays, each item provides an elegant design, while combining robustness and practicality.

Shown Tempo Lamp Charcoal, Arocroc Islande Collection

**NEW**

Tempo Lamps	352
Tempo Mini Lamps	354
Saturno Lamps	355
Lamp Charging	355
Art & Table	356
Serving	357
Wine & Bar	358
ARCOROC	
Ash Trays & Votive	359



# Tempo NEW

Tempo is a rechargeable LED lamp that features a warm light, capable of creating refined atmospheres in each environment, from the lounge to the restaurant.

The design combines elegance and simplicity. It is a high-quality lamp, made of durable and recyclable materials: die-cast aluminum and extruded aluminum.

The lamp features a touch-sensitive button that not only turns it on and off but also allows you to effortlessly adjust the brightness of the light.







**FP349**  
Tempo Lamp Charcoal  
4" x 4" x 11"  
1 Pc.



**FP350**  
Tempo Lamp Copper  
4" x 4" x 11"  
1 Pc.



**FP351**  
Tempo Lamp White  
4" x 4" x 11"  
1 Pc.



# Tempo Mini NEW

The best of the Tempo lamp now in a mini version. Perfect for smaller spaces or an elegant cozy touch to your space.



**FP431**  
Tempo Lamp Mini Charcoal  
4" x 4" x 7 7/8"  
1 Pc.



**FP432**  
Tempo Lamp Mini Copper  
4" x 4" x 7 7/8"  
1 Pc.



**FP433**  
Tempo Lamp Mini White  
4" x 4" x 7 7/8"  
1 Pc.



**FP461**  
Tempo Lamp Mini Sand  
4" x 4" x 7 7/8"  
1 Pc.



**FP460**  
Tempo Lamp Mini Sage  
4" x 4" x 7 7/8"  
1 Pc.





# Saturno NEW

Featuring a warm and cool light option Saturno is the cousin to the Tempo Lamp. Saturno offers sleek vertical lines for a modern and contemporary look.



**FP462**  
Lamp White  
4 3/8" x 4 3/8" x 11 1/2"  
1 Pc.



**FP463**  
Lamp Black  
4 3/8" x 4 3/8" x 11 1/2"  
1 Pc.



# Lamp Charging NEW

Charge 6 lamps at a time. The base comes with 4 poles to be able to stack another charging base (second base sold separately). Fits: Tempo, Tempo Mini and Saturno lamps



**FP430**  
6 Lamp Charger Tray  
21 5/8" x 14 1/8" x 1 3/4"  
1 Pc.



(2) FP430 trays can be stacked to create more charging space.  
*\*Second base sold separately.*

## Art & Table NEW

Explore our selection of 18/10 stainless steel table accessories for an elevated dining experience. These durable and elegant additions are designed to complement your style and enhance your table presentations.



**FP512**  
Supreme Outside Base Cup 18/10  
5 1/8" x 5 1/8" x 3"  
1 Dz.



**FP513**  
Supreme Cup 18/10  
5 1/8" x 5 1/8" x 3 3/8"  
1 Dz.



**FP514**  
Multipurpose Tray 18/10  
9 1/2" x 3 3/4"  
6 Pcs.



**FP471**  
3 Tier Petit Four Stand 18/10  
8 5/8" x 8 5/8" x 12 1/4"  
1 Pc.

# Serving NEW

Discover our professional-grade stainless steel platters and trays, perfect for elevating the dining experience in hotels and restaurants. Designed for durability and style, these versatile pieces enhance presentations, ensuring a sophisticated touch for your establishment.

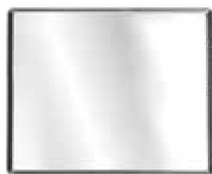

**FP530**  
Pastry/Bar Tray  
9 7/8" x 7 7/8"  
1 Dz.



**FP527**  
Buffet/Bar Tray  
13 3/4" x 4"  
1 Dz.



**FP522**  
Large Pastry/Bar Tray  
23 5/8" x 4"  
1 Dz.



Oval Platter without Rim 18/10

**FP515**  
15 3/4" x 10 5/8"  
6 Pcs.

**FP518**  
17 3/4" x 12 1/4"  
6 Pcs.

**FP520**  
19 3/4" x 13 3/4"  
6 Pcs.



**FP525**  
Large Buffet/Bar Tray  
23 5/8" x 7 7/8"  
1 Dz.



# Wine & Bar NEW

Discover sophistication and functionality with our 18/10 stainless steel ice buckets and stands collection. Take your hosting experience to another level with these sleek and durable essentials, crafted to keep your beverages perfectly chilled.



**FP521**  
Modern Champagne Bucket  
9 1/2" x 9 1/2" x 8 3/8" (6.5 Qt. / 210 Oz.)  
6 Pcs.



**FP473**  
Modern Champagne Bucket  
Round Stand  
10 1/4" x 10 1/4" x 22 1/2"  
1 Pc.



**FP476**  
Stainless Steel Ice Bucket  
with Lid  
5 1/8" x 5 1/8" x 7 1/8"  
1 Pc.

# Ash Trays & Votive

Complete your bar top experience with a votive candle holder that creates tailored experience. Also, provide your customers with a convenient ashtray, keeping your grounds clean.



**C1320** ●  
Clear  
H: 1 3/8" T: 4 1/4"  
B: 3 1/2" M: 4 1/4"  
2 Dz.



**51257** ●  
Clear  
H: 1 1/4" T: 3 1/4"  
B: 2 7/8" M: 3 1/4"  
2 Dz.



**00187** ●  
Black  
H: 1 3/8" T: 4 1/4"  
B: 3 1/2" M: 4 1/4"  
2 Dz.



**55878** ●  
Black  
H: 1 1/4" T: 3 1/4"  
B: 2 7/8" M: 3 1/4"  
2 Dz.



**J3811**  
Votive (3 Oz.)  
H: 2 1/2" T: 1 1/16"  
B: 2" M: 2"  
3 Dz.



# Custom Decorated Glassware

Custom Decorated Glassware is a great way to increase the perceived value of a visit to your establishment—and to stand out from the competition.

Decorated glass draws attention to your beverage selections. If combined with a take home program, it is an especially effective marketing method.

It is the perfect way to control the pour\*, which translates to significant cost savings.

\*Pour lines are approximate and should not be used as an exact measurement.

Contact your Arc Cardinal Consultant to find out how to customize your glassware.



## Take Advantage of our Stocked Decorated Items

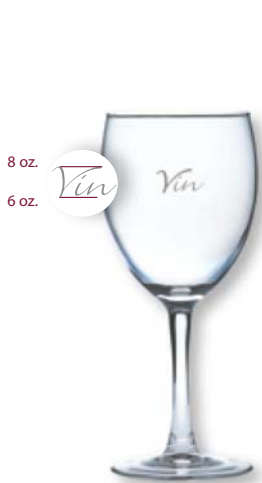

8 oz.  
6 oz.

**D1CM5312**  
Excilibur Vin with pour line (12 Oz.)  
H: 7 1/2" T: 3" B: 3" M: 3 3/8"  
2 Dz.

Approximate Pour Lines:  
(6 Oz.) Bottom of Vin  
(8 Oz.) Top of Vin



9 oz.  
6 oz.

**L0571**  
Cabernet Tall Wine with pour line (16 Oz.)  
H: 8 5/8" T: 2 3/4" B: 3" M: 3 1/2"  
2 Dz.

Approximate Pour Lines:  
(6 Oz.) Bottom of Grapes  
(9 Oz.) Top of Grapes



9 oz.  
6 oz.

**Q1069**  
Sequence Corkscrew Universal (16 Oz.)  
H: 9" T: 2 3/8" B: 3 1/4" M: 3 5/16"  
1 Dz.

Approximate Pour Lines:  
(6 Oz.) Bottom of Corkscrew  
(9 Oz.) Top of Corkscrew

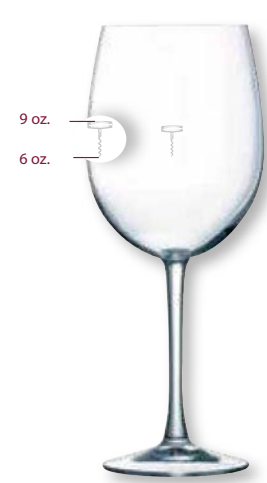

9 oz.  
6 oz.

**V2128**  
Romeo Corkscrew Wine (16 Oz.)  
H: 8 3/8" T: 2 7/8" B: 3" M: 3 3/8"  
1 Dz.

Approximate Pour Lines:  
(6 Oz.) Bottom of Corkscrew  
(9 Oz.) Top of Corkscrew



# Custom Decorated Dinnerware

All of our white ceramic dinnerware patterns can be decorated. With wide options, including but not limited to, banding (shown), logos can also be applied in the well or around the rim. The choices are endless!

**Minimum Order Quantity 12 Dz. All pieces are custom and made to order. For more information on customizing your dinnerware, contact your Arc Cardinal Consultant.**



GOLD RIM

SILVER RIM



GREEN RIM

RED RIM

# Laser Decoration & Etching

Laser etching is great option for a variety of products to showcase your brand in a subtle and sophisticated way. From drinkware, barware, dinnerware and flatware there is wide variety of pieces to choose from.

**Minimum Order Quantity 24 Dz. All pieces are custom and made to order. For more information contact your Arc Cardinal Consultant.**

## FLATWARE AND STEAK KNIFE\*

Not all flatware patterns can be decorated due to surface and/or handle, please inquire about specific patterns. Mirror flatware patterns are available for handle sand or satin finishing.



LASER INTO THE BLADE

LASER W/ BLACK FILL

## DRINKWARE, BARWARE, & DINNERWARE

Not all flatware patterns can be decorated due to surface and/or handle, please inquire about specific patterns. Mirror flatware patterns are available for handle sand or satin finishing.



ETCHED DECORATION

LASER DECORATION

# Acacia Wood & Glassware Reference



**FN282\***  
Acacia Wood MD Rectangle  
Handled Board  
L: 18 ¼" W: 4 ¾"  
4 Pcs.



**FN283\***  
Acacia Wood LG Rectangle  
Handled Board  
L: 21 ½" W: 5 ½"  
4 Pcs.



**FN284\***  
Acacia Wood Square  
Handled Board  
L: 14 7/8" W: 10"  
4 Pcs.

## GLASSWARE & DINNERWARE OPTIONS COMPATIBLE WITH ACACIA WOOD BOARDS

### INNER CIRCLE 2"- 2 1/8"

#### ARCOROC

- V5927** Shetland Hi Ball (12 Oz.)
- C8303** Perfection Tumbler (15 Oz.)
- J4094** Gotham Rocks (4 ½ Oz.)
- P6284** Perfection Tumbler (12 Oz.)
- FM120** Outdoor Perfect Stemless Wine (15 Oz.)
- R0741** Appetizer Deep Bowl (5 Oz.)

#### Chef & Sommelier - FRANCE -

- G3658** Cabernet Hi Ball (7 ¾ Oz.)
- U1032** Open Up Warm Tumbler (10 Oz.)
- G3322** Primary DOF (12 Oz.)
- G3368** Lima Hi Ball (12 ¾ Oz.)
- N0834** Macaron Rocks (13 ½ Oz.)
- G3323** Primary Beverage (14 ¾ Oz.)
- FM559** Eternity Plus Apex Mug (12 Oz.)
- FM537** Eternity Plus Bouillion/ Sugar (7 ¾ Oz.)

### OUTER CIRCLE 3 5/8" \*\*

#### Chef & Sommelier - FRANCE -

- L3963** Fluid Carafe (16 ¾ Oz.)
- L5636\*\*** Sequence Burgundy (20 ½ Oz.)
- L5637\*\*** Sequence Bordeaux (26 Oz.)
- FJ035\*\*** Cabernet Bordeaux (21 ¼ Oz.)

# Glassware Care & Handling

Elegant dinnerware, shining cutlery, fresh linens and sparkling glassware make an impression on your customers that is almost as important as what is on your menu. As such, high-quality tableware is a big investment — protecting and maintaining this investment is essential to the success of your operation.

Thermal shock (sudden temperature change causing stress and often resulting in breakage) and mechanical shock (impact causing chipping, cracking, or breakage) are the primary factors affecting the life cycle of glassware.

Food service glassware absorbs thermal and mechanical shocks on a daily basis. Eventually, it will give in to the buildup of these shocks, and breakage will occur. If your glassware shows the wear and tear of rigorous use, it should be retired — before it can break in-service or otherwise affect your customers' opinion of your operation.

## GLASSWARE DO'S

**ALWAYS** separate glassware, dinnerware and flatware bus tubs.

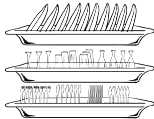

**ALWAYS** use an ice scoop to fill glasses with ice

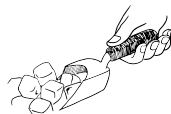

**ALWAYS** stack items specially marked as stackable



**ALWAYS** allow freshly washed glasses to return to room temperature before going back into service



**ALWAYS** preheat glasses used for warm drinks with warm water.



**ALWAYS** remove chipped or cracked glassware from service for safety reasons.



**ALWAYS** load glassware into a plastic storage rack.



**ALWAYS** use the proper racks for each glass.

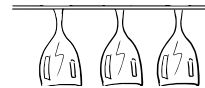

**ALWAYS** remove ice and beverage before placing glass in bus tub to allow the glass to return to room temperature before dishwashing (to avoid thermal shock).

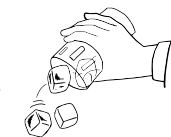

**ALWAYS** keep the proper amount of par levels for the operation.

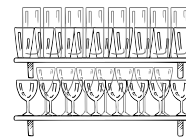

## GLASSWARE DONT'S

**NEVER** mix glassware, dinnerware and flatware in the same bus tub.



**NEVER** scoop ice with glasses.

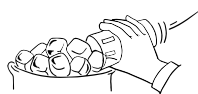

**NEVER** stack glasses that are not marked stackable.



**NEVER** use dishwasher warm glass for serving cold beverages

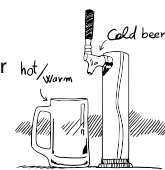

**NEVER** have glass to glass contact—avoid picking more than 1 glass up at once.



**NEVER** put flatware into glasses.



**NEVER** allow the glass to make contact with the beer tap.



**NEVER** allow glassware to remain soiled overnight or for long periods (max 2 hours).



# Dinnerware Care & Handling

Food service dinnerware handles a heavy workload — and while Arc Cardinal builds dinnerware for such usage, there are some simple steps that can be taken to significantly prolong the life and look of these products. The following guidelines cover various troubleshooting and maintenance ideas that are applicable to all types of dinnerware.

## DINNERWARE DO'S

**ALWAYS** use a plastic scraper, sink sprayer or gloved hand to remove stubborn food.



**ALWAYS** use proper dish racks for plates and hollowware items during dish washing.

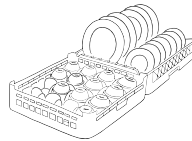

**ALWAYS** separate dinnerware from glassware and flatware in bus buckets.

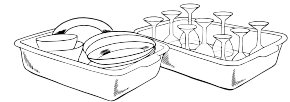

**ALWAYS** have your commercial dishwasher serviced regularly to ensure proper water balance and rinse aid.



**ALWAYS** allow dinnerware to cool after dishwashing to room temperature and thoroughly dry before storing or putting back in service.

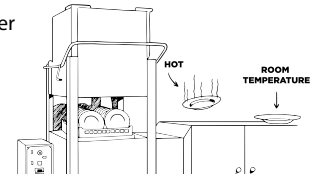

## DINNERWARE DONT'S

**NEVER** use metal pads, steel wool or abrasive cleaners.



**NEVER** stack dishes more than 1 ft. high.



**NEVER** overload bus buckets.

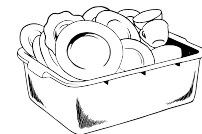

**NEVER** bang dinnerware on waste can or warewashing table to avoid chipping and damage to dinnerware.



**NEVER** leave soiled dinnerware overnight to avoid staining of surfaces from certain beverages and sauces.

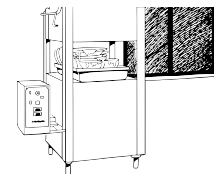

## ARC CARDINAL FIVE-YEAR EDGE CHIP WARRANTY

Select Chef & Sommelier and Arcoroc collections offer a five-year edge chip warranty as standard on ALL pieces within the collections – including the squares, rectangles and cups – yes, everything. (Conditions available upon request.)

# Flatware Care & Handling

Strict adherences to specifications and stringent quality controls at each stage of production make Chef & Sommelier, Sola and Arcoroc flatware resistant and reliable. We meticulously scrutinize our items to ensure they are of the correct gauge, an important guarantee of durability.

Arc Cardinal offers flatware made from 18/10 stainless steel and is designed to withstand intensive use and industrial dishwasher conditions. Whether classic or modern, you will find the Chef & Sommelier, Sola, or Arcoroc pattern that fits your needs in terms of aesthetics and user requirements. For your peace of mind, our 18/10 products come with a 10-year guarantee, applicable in case of any defect in the materials or production. This guarantee is only valid if all recommendations for use (listed below) are followed. Damage due to normal wear and tear, an accident, improper use, excessive use of detergents or use of non-compliant detergents is not covered by this guarantee. This does not cover discoloration, scratching or staining.

## DINNERWARE DO'S

**ALWAYS** separate flatware from other items in the bus tray.

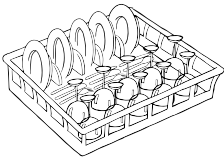

**ALWAYS** rinse flatware after use before loading in the dishwasher.

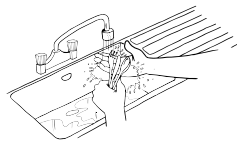

**ALWAYS** empty dishwasher immediately after completion of cycle and dry flatware with a soft cloth.



**ALWAYS** store flatware in a dry place.



**ALWAYS** use the proper flatware racks for ware-washing to encourage water to dry/drain quickly and minimize scratching.

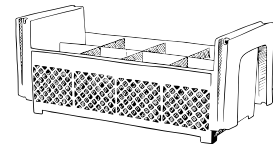

## DINNERWARE DONT'S

**NEVER** use detergent with lemon or other citrus added.



**NEVER** wash silver and stainless together to avoid discoloration.



**NEVER** use silver cleaner to wash stainless.



**NEVER** use flatware for cooking as intense heat could damage the flatware.



# Glassware Par Levels

To calculate standard usage quantities for your establishment, select the appropriate type of operation, and then simply multiply the number of seats by the number listed below.

Example:

125 Seat Fine Dining Restaurant x 11 Oz. Water (3) = 375 Glass recommended order quantity.

200 Seat Banquet x 8 ½ Oz. Wine (1 ½) = 300 Glass recommended order quantity.

100 Seat Upscale Casual Restaurant x 12 Oz. Iced Tea (1 ½) = 150 recommended glass order quantity.

Item	Segment		
	Fine Dining	Casual Upscale	Banquet
Old Fashioned / Rocks 8 ½ Oz.	3	3	2
Double Rocks / DOF 10 ½ - 14 Oz.	3	3	2
Beverage 12 ½ Oz.	3	3	2
Beer 16 Oz.	2	2	2
Wine 8 ½ Oz.	2	3	2
Flute 6 Oz.	2	3	2
Cocktail 7 ½ Oz.	1 ½	2	1 ½
Cocktail 10 Oz.	1 ½	2	1 ½
Margarita 12 - 14 Oz.	1 ½	1 ½	1 ½
Shot 1 ¼ Oz.	1 ½	1 ½	1 ½
Cordial 4 Oz.	1 ½	1 ½	1 ½
Juice 5 - 6 Oz.	1 ½	1 ½	1 ½
Water / All Purpose 11 - 14 Oz.	3	3	3
Iced Tea 12 - 16 Oz.	1 ½	1 ½	1 ½
Wine 16 - 20 Oz.	1	1	1
Flute 5 ¾ Oz.	2	3	3

# Flatware Par Levels

To calculate standard usage quantities for your establishment, select the appropriate type of operation, and then simply multiply the number of seats by the number listed below.

Example:

125 Seat Fine Dining Restaurant x Teaspoon (5) = 625 Teaspoon recommended order quantity.

100 Seat Fine Dining Restaurant x Iced Tea Spoon (1 ½) = 150 Iced Tea Spoon recommended order quantity.

200 Seat Upscale Casual Restaurant x Dinner Knife (2) = 400 Dinner Knife recommended order quantity.

Item	Segment		
	Fine Dining	Upscale Casual	Catering
Teaspoon	4	3	3
Dessert or Soup Spoon	2	2	3
Tablespoon	¼	¼	-
Iced Teaspoon	1 ½	1	-
Demitasse Spoon	2	1	2
Utility/Dessert Fork	2	1 ½	2
Dinner Fork	2	2	3
Oyster or Cocktail Fork	2	1	1 ½
Dinner Knife (SH)	2	2	3
Utility/Dessert Knife	2	1 ½	2
B&B Knife or Butter Spreader	2	2	3

# Dinnerware Par Levels

To calculate standard usage quantities for your establishment, select the appropriate type of operation, and then simply multiply the number of seats by the number listed below.

Example:

125 Seat Fine Dining Restaurant x 10 ¼" – 10 ⅜" Dinner Plate (2) = 250 Plate recommended order quantity.

100 Seat Fine Dining Restaurant x Coffee/Tea Cup (3) = 300 Cup recommended order quantity.

200 Seat Upscale Casual Restaurant x 5 ½" – 6 ⅝" Bread Plate (2) = 400 Plate recommended order quantity.

Item	Segment			
	Fine Dining	Upscale Casual	Catering	Banquet
Bread & Butter Plates	2	2	2	6
Salad/ Dessert Plates	2	2	2	-
Lunch Plate	2	2	2	2
Dinner Plate 9 ¾" - 10"	3	1 ½	1 ½	2
Dinner Plate 10 ¼" – 10 ⅜"	2	2	2	-
Platters 7 ¼" – 9 ⅞"	1 ½	1	1	-
Platters 11" - 15"	1 ½	1	1	1 ½
Coffee/Tea Cup	3	3	2	2
Bouillon, Handled or Non-handled	1	1 ½	1 ½	1 ½
Mug	2	2	2	2
Saucers	3	3	2	2
Fruit Dish	3	2	2 ½	6
Grapefruits	1	1	1	1 ¼
Cereal Bowl	1	1	1	½
Rim/Deep Soup	½	½	½	-
Coffee/Tea Pot	½	½	½	-
Creamer (Pitcher)	½	½	½	-
Service Plate	1 ½	1 ½	1 ½	-

## Pakkawood Care & Handling

- **ALWAYS** Dry immediately after washing
- To maintain wood appearance, rub a little food safe oil on the handles monthly
- Dishwasher not recommended
- **NEVER** use any form of chlorine bleach which will discolor
- **NEVER** use pre-soak
- **NEVER** soak in water
- **NEVER** use cleaning solutions containing ammonia or lemon
- **NEVER** use steel wool to clean

# Chasseur Care & Use



## BEFORE USE

- Wash in hot water, rinse and dry thoroughly before first use.
- We recommend pre-seasoning. Even pre-seasoned cast iron can use some extra protection.
- To season your pan, heat it up on the stove top until its hot, then rub a little oil into it and let it cool.
- Clean it after each use.
- Pre-season as needed.

## CLEANING & CARE

- Let pans cool before washing in warm water. Soak first in warm water and detergent to remove burnt on food.
- Always use wooden, plastic or silicone utensils, avoid metal.
- Do not tap the edges of the container & never cut food inside the cookware as you risk scratching or damaging the enamel.
- Use non-abrasive nylon scourers.
- Always dry thoroughly before storing.
- Avoid the use of a dishwasher after every use to prolong the longevity of the product.
- Heating in the oven may cause the metal knobs to change color slightly.

## ARC CARDINAL ITEMS THAT FIT TRIVETS:

### Items that Fit FN976 (Round Trivet)

FN421  
Mini Round Matte Black Casserole  
0.37 Q (11 7/8 Oz.)

FN422  
Mini Round Matte Ruby Casserole  
0.37 Q (11 7/8 Oz.)

FN423  
Mini Round Matte Black Casserole  
0.63 Q (20 1/4 Oz.)

FN424  
Mini Round Matte Ruby Casserole  
0.63 Q (20 1/4 Oz.)

P0310  
Smart Cuisine Creme Brulee Dish  
(9 1/2 Oz.)

### Items that Fit FN977 (Oval Trivet)

FN417  
Round Matte Black Dish  
5 7/8" (15 cm)

FN418  
Round Matte Black Dish  
7 1/6" (18 cm)

### Items that Fit FN978 (Oval Trivet)

FN419  
Oval Matte Black Dish  
7 7/8" x 5 7/8" (20 cm)





## GENERAL CARE

- Before first use, and as soon as possible after each use, wash all parts with warm, soapy water. Rinse all parts thoroughly and allow time to dry. Store with stopper off.
- Contents should not be left in the container for longer than 24 hours. As soon as possible after each and every use, wash all parts with warm, soapy water. Rinse all parts thoroughly with clean water. Allow all parts to dry completely prior to next use or storage.
- DO NOT use abrasive soaps, scouring pads, brushes, or other objects to clean inside of container.
- DO NOT use abrasive cleaners or scrubbers to clean outside of product since they may dull finish.
- This product is top-rack dishwasher safe; however, hand washing is recommended as the dishwasher uses harsher detergents and hot water that may affect the appearance of your product.
- Residual liquids, foods, or other contents may become trapped between product components, such as lid parts, container parts, gaskets (flexible band around lid and/or stopper), or straws (if present in the product). Although this product is top-rack dishwasher safe, hand washing is recommended to ensure that these parts of the product are thoroughly cleaned.
- For maximum thermal efficiency, preheat or pre-chill the product just prior to use. Fill with hot/cold tap water, attach lid, let stand 5 to 10 minutes and empty water. After filling container with contents, re-cover with lid to increase thermal efficiency. Never use a microwave, conventional oven, or other heat source for this purpose.

## ASSEMBLY & USE

### TWIST-AND-POUR STOPPER (IF PRESENT):

1. Remove stopper (A) by twisting counterclockwise.
2. Remove gasket(s) (B and B1 - if present) from underside of stopper (A).
3. Wash all parts separately, then re-assemble. Ensure gasket(s) (B and B1 - if present) are properly seated to minimize leaking.

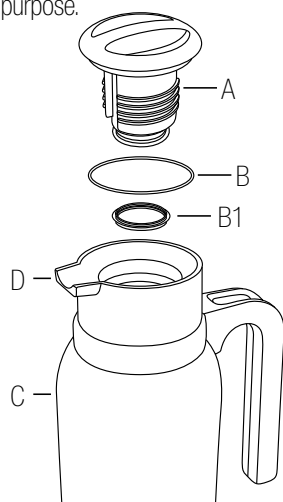

\* Image for reference only: actual product may vary

4. Fill container (C) with contents. Do not overfill: Leave space for the stopper (A), to avoid overflow.
5. Replace stopper (A) by twisting clockwise.
6. To pour, twist stopper (A) counterclockwise  $\frac{1}{2}$  - 1 turn. Orient product so that pour indicator arrow is pointing in-line with spout (D). Proceed to pour. Note: Stopper does not need to be removed completely to pour contents.
7. Re-tighten stopper (A) by twisting clockwise.

### PUSH-BUTTON STOPPER (IF PRESENT):

1. Remove stopper (E) by twisting counterclockwise.
2. To disassemble, lift up on stopper-tab (K) of stopper-cover (L) until completely removed.
3. Depress and twist washer (M) clockwise until it aligns with washer-post (Q). Washer-spring (N) will naturally release washer (M).
4. Remove washer-spring (N).
5. Remove valve-plate (R) and valve-spring (P) by pulling downward on base of valve-plate (R).
6. Remove gaskets (H and I).
7. Wash all parts separately, then re-assemble. Ensure gaskets (H and I) are properly seated to minimize leaking.
8. Fill container (G) with contents. Do not overfill: Leave space for the stopper (E), to avoid overflow.
9. Replace stopper (E) by twisting clockwise. Depress the push-button (O) 2 to 3 times to release pressure.
10. Securely grip handle (J) and press push-button (O).
11. Tilt product and pour contents through spout (F).
12. Bring product to an upright position and release push-button (O).

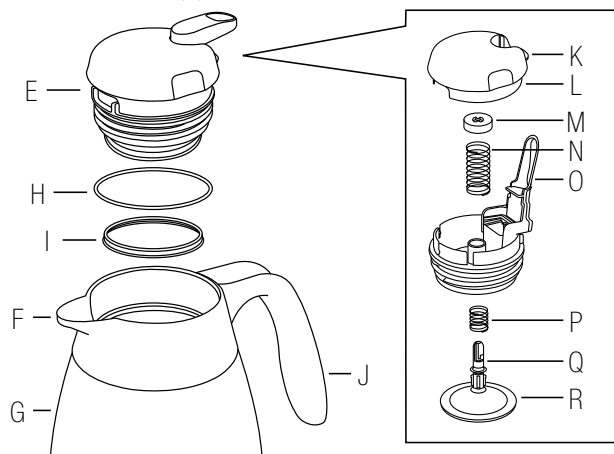

## CARE AND USE GUIDE

### VACUUM INSULATED STAINLESS STEEL CARAFE

#### GENERAL CARE

- Before first use, and as soon as possible after each use, rinse all parts with warm, soapy water. Rinse thoroughly with fresh water and allow time to dry. Store with stopper off.
- Contents should not be left in the container for longer than 24 hours. As soon as possible after each and every use, wash all parts with warm, soapy water. Rinse all parts thoroughly with clean water. Allow all parts to dry completely prior to next use or storage.
- DO NOT use abrasive cleaners or scrubbers to clean outside of product since they may dull finish.
- DO NOT use bleach or cleaners containing chlorine on any parts of product.
- HANDWASH ONLY - this product is not dishwasher safe.
- DO NOT immerse or soak in water for prolonged periods of time. Residual liquids, foods, or other contents may become trapped between product components, such as lid parts, container parts, gaskets (flexible band around lid and/or stopper), or straws (if present in the product). Hand washing is recommended to ensure that all parts of the product are thoroughly cleaned.
- For maximum thermal efficiency, preheat or pre-chill the product just prior to use. Fill with hot/cold tap water, attach lid, let stand 5 to 10 minutes and empty water. After filling container with contents, re-cover with lid to increase thermal efficiency. Never use a microwave, conventional oven, or other heat source for this purpose.

#### PUSH-LEVER LID (IF PRESENT):

1. Remove lid (A) by twisting counterclockwise.
2. Wash all parts separately, then re-assemble. See General Care section above for washing instructions.
  - a. Ensure gaskets (if present) are properly seated to minimize leaking.
3. Fill container with contents. Do not overfill: Leave space for the lid (A) to avoid overflow.
4. Replace lid (A) by twisting clockwise. Depress the push-lever (A1) 2 to 3 times to release pressure.
5. To pour, securely grip handle (B) and press push-lever (A1).
6. Tilt product and pour contents through spout (A2).
7. Bring product to an upright position and release push-lever (A1) to close.

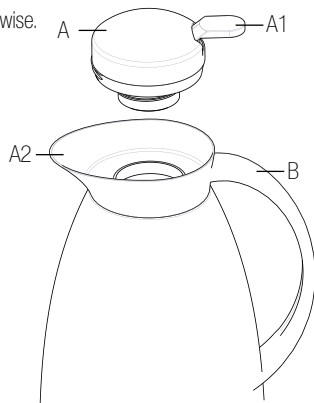

#### HINGED LID (IF PRESENT):

1. Lift lid (A) by pressing on the hinge lever (A1).
2. Wash all parts. See General Care section above for washing instructions.
3. Before filling, open lid (A) all the way. Fill container with contents.
  - a. Do not overfill: Leave space for the lid (A) to avoid overflow.

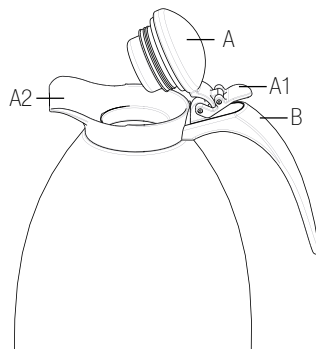

Image for reference only: Actual product may vary.

4. To pour, securely grip handle (B) and press and hold hinge lever (A1). Hinge lever (A1) must be held while pouring to ensure easy flow of contents.
5. Tilt product and pour contents through spout (A2).
6. Bring product to an upright position and release hinge lever (A1).
7. To close, press down on the lid (A) into the lid opening until the lid (A) is secure.
  - a. Hinge lever (A1) may need to be adjusted to better align the lid and lid opening.

## CARE AND USE GUIDE

### GLASS VACUUM INSULATED CARAFE

#### EN

#### GENERAL CARE

- Before first use, and as soon as possible after each use, rinse all parts with warm, soapy water. Rinse thoroughly with fresh water and allow time to dry. Store with stopper off.
- Contents should not be left in the container for longer than 24 hours. As soon as possible after each and every use, wash all parts with warm, soapy water. Rinse all parts thoroughly with clean water. Allow all parts to dry completely prior to next use or storage.
- DO NOT use abrasive cleaners or scrubbers to clean outside of product since they may dull finish.
- DO NOT use bleach or cleaners containing chlorine on any parts of product.
- HANDWASH ONLY - this product is not dishwasher safe.
- DO NOT immerse or soak in water for prolonged periods of time. Residual liquids, foods, or other contents may become trapped between product components, such as lid parts, container parts, gaskets (flexible band around lid and/or stopper), or straws (if present in the product). Hand washing is recommended to ensure that all parts of the product are thoroughly cleaned.
- For maximum thermal efficiency, preheat or pre-chill the product just prior to use. Fill with hot/cold tap water, attach lid, let stand 5 to 10 minutes and empty water. After filling container with contents, re-cover with lid to increase thermal efficiency. Never use a microwave, conventional oven, or other heat source for this purpose.

#### PUSH-LEVER LID (IF PRESENT):

1. Remove lid (A) by twisting counterclockwise.
2. Wash all parts separately, then re-assemble. See General Care section above for washing instructions.
  - a. Ensure gaskets (if present) are properly seated to minimize leaking.
3. Fill container with contents. Do not overfill: Leave space for the lid (A) to avoid overflow.
4. Replace lid (A) by twisting clockwise. Depress the push-lever (A1) 2 to 3 times to release pressure.
5. To pour, securely grip handle (B) and press push-lever (A1).
6. Tilt product and pour contents through spout (A2).
7. Bring product to an upright position and release push-lever (A1) to close.

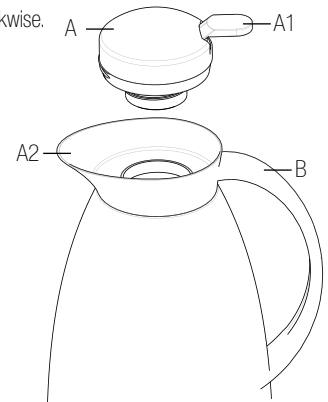

# Index

00016	..... 129	36140	..... 249	71078	..... 72	E1513	..... 81
00187	..... 361	36229	..... 141	71079	..... 72, 133	E1514	..... 81
00213	..... 71, 125	37684	..... 80	71080	..... 70	E1515	..... 81
00556	..... 254	40375	..... 129	71081	..... 72, 126	E1907	..... 108
01141	..... 254	42258	..... 133	71083	..... 70	E1908	..... 143
01158	..... 254	43100	..... 138	71084	..... 70	E2788	..... 25
01166	..... 254	43279	..... 79	71086	..... 71, 119	E2789	..... 25
04757	..... 72	43281	..... 79	71092	..... 72	E2790	..... 25
04900	..... 140	43319	..... 249	71093	..... 72, 126	E3562	..... 68
06942	..... 70	43716	..... 139	75926	..... 69	E5358	..... 132
07134	..... 137	43745	..... 143	76495	..... 143	E5458	..... 103, 138
07395	..... 72	43746	..... 143	79320	..... 71, 125	E6125	..... 119, 156
09232	..... 71, 125	44273	..... 138	79736	..... 108	E6127	..... 127, 157
10007	..... 102	46888	..... 24	C0198	..... 145	E6128	..... 127, 157
10291	..... 145	46973	..... 23	C0678	..... 148	E6131	..... 156
11874	..... 80	46978	..... 23	C0790	..... 142	E6132	..... 125, 157
12652	..... 105, 131	46981	..... 25	C1320	..... 361	E6133	..... 157
12926	..... 72	47017	..... 25	C1643	..... 142	E6134	..... 156
14611	..... 249	47019	..... 25	C2172	..... 127	E6136	..... 156
14798	..... 26, 132	47026	..... 25	C3544	..... 137	E6137	..... 156
15012	..... 77	47346	..... 102, 129	C3966	..... 129	E6138	..... 156
17198	..... 102	48024	..... 26, 117	C5872	..... 139	E6141	..... 141, 156
19188	..... 129	50061	..... 249	C8303	..... 106, 364	E7254	..... 148
19343	..... 138	50816	..... 23	C8304	..... 106	E7255	..... 148
19415	..... 141	50998	..... 255	C8832	..... 106	E7258	..... 148
19416	..... 141	51257	..... 361	CA030	..... 123	E7695	..... 33
20864	..... 73	52643	..... 139	CA031	..... 123	E7696	..... 33
20865	..... 73	53205	..... 100	CA504	..... 123	E7697	..... 33
20866	..... 73	53214	..... 100	CAP01	..... 153	E7698	..... 33
20867	..... 73	53224	..... 100	CAP02	..... 153	E7700	..... 33, 117
20868	..... 73	53232	..... 100	CAP04	..... 152	E8007	..... 244
20869	..... 73	53403	..... 80	CAP05	..... 152	E8792	..... 139
20871	..... 73	53404	..... 142	CAP07	..... 153	E9155	..... 255
20873	..... 73	53664	..... 69	CAP09	..... 153	E9156	..... 255
20874	..... 73	53673	..... 145	CAP18	..... 151	E9157	..... 255
20875	..... 73	53675	..... 145	CAP20	..... 151	E9158	..... 255
21053	..... 141	55878	..... 361	CAP28	..... 151	E9159	..... 255
21554	..... 129	57069	..... 69	CAP32	..... 150	E9298	..... 148, 157
22032	..... 138	57070	..... 69	CAP51	..... 150	EB165	..... 173
22506	..... 248	57286	..... 69	D1C08365	..... 145	EB182	..... 173
22514	..... 249	57974	..... 248	D1CM5312	..... 70, 362	EB217	..... 173
22522	..... 248	57975	..... 248	D0129	..... 140	EB248	..... 173
22530	..... 248	58010	..... 255	D0130	..... 103	EB255	..... 173
22712	..... 249	58012	..... 255	D0575	..... 105	EB260	..... 173
25263	..... 141	58621	..... 248	D0616	..... 105, 131	EB281	..... 173
25269	..... 249	60440	..... 80	D0795	..... 24	EB288	..... 173
25275	..... 141	61697	..... 80	D0796	..... 26, 117	EB298	..... 173
25285	..... 249	61698	..... 80	D2024	..... 71, 125	EG105	..... 190
25293	..... 249	61875	..... 80	D2443	..... 142	EG162	..... 189
28891	..... 249	62664	..... 133	D6315	..... 69	EG178	..... 190
29337	..... 249	64733	..... 249	D6653	..... 144	EG205	..... 189
29811	..... 143	71075	..... 71	D7410	..... 245	EG216	..... 189
33040	..... 145	71076	..... 72	D9219	..... 80	EG229	..... 189

EG243 ..... 189  
EG254 ..... 189  
EG267 ..... 189  
EG271 ..... 189  
EG273 ..... 189  
EG292 ..... 189  
EG295 ..... 189  
EG356 ..... 189  
EJ105 ..... 190  
EJ162 ..... 189  
EJ178 ..... 190  
EJ205 ..... 189  
EJ216 ..... 189  
EJ229 ..... 189  
EJ243 ..... 189  
EJ254 ..... 189  
EJ267 ..... 189  
EJ271 ..... 189  
EJ273 ..... 189  
EJ292 ..... 189  
EJ295 ..... 189  
EJ318 ..... 189  
EJ356 ..... 189  
ELG01 ..... 297  
EO165 ..... 173  
EO182 ..... 173  
EO217 ..... 173  
EO248 ..... 173  
EO255 ..... 173  
EO260 ..... 173  
EO281 ..... 173  
EO288 ..... 173  
EO298 ..... 173  
EO355 ..... 173  
EP105 ..... 190  
EP162 ..... 189  
EP178 ..... 190  
EP205 ..... 189  
EP216 ..... 189  
EP229 ..... 189  
EP243 ..... 189  
EP254 ..... 189  
EP267 ..... 189  
EP271 ..... 189  
EP273 ..... 189  
EP292 ..... 189  
EP295 ..... 189  
EP318 ..... 189  
EP356 ..... 189  
EP777 ..... 198  
EQ283 ..... 260  
EQ284 ..... 260  
EQ285 ..... 260  
EQ286 ..... 260  
EQ287 ..... 260

EQ288 ..... 260  
EQ289 ..... 260  
EQ290 ..... 260  
EQ291 ..... 260  
EQ292 ..... 260  
EQ293 ..... 260  
EQ294 ..... 260  
EQ295 ..... 260, 295  
ESK01 ..... 295  
EV318 ..... 189  
FE644 ..... 145  
FF192 ..... 227  
FF193 ..... 227  
FF194 ..... 227  
FF195 ..... 227  
FF196 ..... 227  
FF198 ..... 227  
FF199 ..... 227  
FF200 ..... 227  
FF201 ..... 227  
FF202 ..... 227  
FG701 ..... 284  
FG704 ..... 284  
FG706 ..... 284  
FG709 ..... 284  
FG718 ..... 284  
FG726 ..... 284, 297  
FG727 ..... 264  
FG728 ..... 284  
FG729 ..... 284  
FH285 ..... 215  
FH286 ..... 215  
FH287 ..... 215  
FH288 ..... 215  
FH289 ..... 215  
FH608 ..... 215  
FH609 ..... 215  
FH610 ..... 215  
FH611 ..... 215  
FH614 ..... 215  
FH615 ..... 215  
FH621 ..... 215  
FJ014 ..... 149  
FJ015 ..... 149  
FJ016 ..... 149  
FJ035 ..... 23, 364  
FJ036 ..... 23  
FJ060 ..... 109  
FJ061 ..... 109  
FJ062 ..... 109  
FJ063 ..... 109  
FJ506 ..... 294  
FJ507 ..... 294  
FJ508 ..... 294  
FJ516 ..... 295

FJ517 ..... 295  
FJ611 ..... 294  
FJ612 ..... 294  
FJ701 ..... 264  
FJ704 ..... 264  
FJ706 ..... 264  
FJ708 ..... 264  
FJ709 ..... 264  
FJ801 ..... 286  
FJ804 ..... 286  
FJ806 ..... 286  
FJ828 ..... 286  
FJ829 ..... 286  
FJ909 ..... 286  
FJ911 ..... 286  
FK203 ..... 106  
FK258 ..... 109  
FK259 ..... 109  
FK307 ..... 294  
FK364 ..... 128  
FK368 ..... 128  
FK401 ..... 266  
FK404 ..... 266  
FK406 ..... 266  
FK428 ..... 266  
FK429 ..... 266  
FK492 ..... 128  
FK493 ..... 128  
FK501 ..... 267  
FK504 ..... 267  
FK506 ..... 267  
FK528 ..... 267  
FK529 ..... 267  
FK548 ..... 195  
FK596 ..... 151  
FK603 ..... 294  
FK639 ..... 211  
FK640 ..... 211  
FK641 ..... 211  
FK642 ..... 211  
FK643 ..... 211  
FK644 ..... 211  
FK645 ..... 211  
FK646 ..... 211  
FK763 ..... 213  
FK764 ..... 213  
FK765 ..... 213  
FK766 ..... 213  
FK767 ..... 213  
FK768 ..... 213  
FK769 ..... 213  
FK770 ..... 213  
FK774 ..... 213  
FK775 ..... 213  
FK777 ..... 213

FK788 ..... 195  
FK789 ..... 195  
FK790 ..... 195  
FK801 ..... 263  
FK802 ..... 263  
FK804 ..... 263  
FK806 ..... 263  
FK809 ..... 263  
FK828 ..... 263  
FK829 ..... 263  
FK843 ..... 195  
FK844 ..... 195  
FK848 ..... 195  
FK856 ..... 142  
FK889 ..... 195  
FK943 ..... 195  
FK944 ..... 195  
FK989 ..... 195  
FL101 ..... 288  
FL104 ..... 288  
FL106 ..... 288  
FL109 ..... 288  
FL118 ..... 288  
FL128 ..... 288  
FL129 ..... 288  
FL201 ..... 261  
FL202 ..... 261  
FL204 ..... 261  
FL206 ..... 261  
FL209 ..... 261  
FL211 ..... 261  
FL218 ..... 261  
FL221 ..... 261  
FL227 ..... 261  
FL228 ..... 261  
FL229 ..... 261  
FL337 ..... 137  
FL338 ..... 137  
FL401 ..... 286  
FL402 ..... 286  
FL404 ..... 286  
FL406 ..... 286  
FL409 ..... 286  
FL418 ..... 286  
FL428 ..... 286  
FL429 ..... 286  
FL470 ..... 145  
FL501 ..... 284  
FL502 ..... 284  
FL504 ..... 284  
FL506 ..... 284  
FL509 ..... 284  
FL518 ..... 284  
FL528 ..... 284  
FL529 ..... 284

FL601 ..... 283  
 FL604 ..... 283  
 FL606 ..... 283  
 FL609 ..... 283  
 FL628 ..... 283  
 FL629 ..... 283  
 FL643 ..... 195  
 FL644 ..... 195  
 FL645 ..... 195  
 FL646 ..... 195  
 FL647 ..... 195  
 FL648 ..... 195  
 FL651 ..... 195  
 FL701 ..... 262  
 FL702 ..... 262  
 FL704 ..... 262  
 FL706 ..... 262  
 FL709 ..... 262  
 FL711 ..... 262  
 FL718 ..... 262  
 FL721 ..... 262  
 FL727 ..... 262  
 FL728 ..... 262  
 FL729 ..... 262  
 FL901 ..... 259  
 FL902 ..... 259  
 FL904 ..... 259  
 FL906 ..... 259  
 FL909 ..... 259  
 FL913 ..... 259  
 FL927 ..... 259  
 FL928 ..... 259  
 FL929 ..... 259  
 FL940 ..... 259  
 FL941 ..... 271  
 FL942 ..... 271  
 FL946 ..... 271  
 FL948 ..... 271  
 FL951 ..... 271  
 FL952 ..... 271  
 FL953 ..... 271  
 FM077 ..... 156  
 FM120 ..... 156, 364  
 FM381 ..... 209  
 FM382 ..... 215  
 FM400 ..... 158  
 FM403 ..... 158  
 FM501 ..... 285  
 FM502 ..... 285  
 FM504 ..... 285  
 FM505 ..... 285  
 FM506 ..... 285  
 FM509 ..... 285  
 FM518 ..... 285  
 FM528 ..... 285

FM529 ..... 285  
 FM530 ..... 285  
 FM536 ..... 197  
 FM537 ..... 198, 364  
 FM538 ..... 197  
 FM539 ..... 196  
 FM540 ..... 199  
 FM541 ..... 199  
 FM542 ..... 197  
 FM543 ..... 199  
 FM544 ..... 197  
 FM545 ..... 197  
 FM546 ..... 199  
 FM547 ..... 197  
 FM548 ..... 197  
 FM549 ..... 197  
 FM550 ..... 198  
 FM551 ..... 196  
 FM552 ..... 198  
 FM553 ..... 197  
 FM554 ..... 197  
 FM555 ..... 198  
 FM556 ..... 196  
 FM557 ..... 198  
 FM558 ..... 197  
 FM559 ..... 199, 364  
 FM560 ..... 197  
 FM561 ..... 198  
 FM562 ..... 198  
 FM563 ..... 199  
 FM564 ..... 196  
 FM566 ..... 197  
 FM567 ..... 198  
 FM568 ..... 197  
 FM569 ..... 197  
 FM570 ..... 197  
 FM571 ..... 270  
 FM575 ..... 270  
 FM577 ..... 270  
 FM578 ..... 270  
 FM579 ..... 270  
 FM580 ..... 270  
 FM581 ..... 270  
 FM582 ..... 270  
 FM583 ..... 270  
 FM584 ..... 270  
 FM601 ..... 290  
 FM604 ..... 290  
 FM606 ..... 290  
 FM609 ..... 290  
 FM611 ..... 290  
 FM627 ..... 290  
 FM628 ..... 290  
 FM629 ..... 290  
 FM711 ..... 267

FM713 ..... 199  
 FM721 ..... 267  
 FM729 ..... 177  
 FM730 ..... 177  
 FM732 ..... 177  
 FM733 ..... 177  
 FM736 ..... 177  
 FM737 ..... 177  
 FM738 ..... 177  
 FM739 ..... 177  
 FM740 ..... 176  
 FM741 ..... 176  
 FM742 ..... 190  
 FM743 ..... 190  
 FM744 ..... 190  
 FM745 ..... 190  
 FM746 ..... 190  
 FM747 ..... 190  
 FM748 ..... 190  
 FM749 ..... 190  
 FM750 ..... 190  
 FM751 ..... 190  
 FM752 ..... 190  
 FM753 ..... 190  
 FM754 ..... 190  
 FM755 ..... 190  
 FM756 ..... 190  
 FM757 ..... 190  
 FM758 ..... 190  
 FM759 ..... 190  
 FM760 ..... 190  
 FM761 ..... 190  
 FM762 ..... 190  
 FM763 ..... 190  
 FM764 ..... 190  
 FM765 ..... 190  
 FM888 ..... 197  
 FM900 ..... 199  
 FM901 ..... 199  
 FM902 ..... 199  
 FM903 ..... 199  
 FM904 ..... 199  
 FM913 ..... 189  
 FM914 ..... 189  
 FM915 ..... 189  
 FMO05 ..... 259  
 FMO06 ..... 295  
 FMO08 ..... 259  
 FMO12 ..... 259  
 FMO26 ..... 259, 295  
 FN001 ..... 200  
 FN002 ..... 200  
 FN003 ..... 200  
 FN004 ..... 200  
 FN006 ..... 200

FN011 ..... 200  
 FN017 ..... 201  
 FN019 ..... 201  
 FN022 ..... 201  
 FN026 ..... 201  
 FN028 ..... 201  
 FN031 ..... 201  
 FN033 ..... 201  
 FN034 ..... 201  
 FN038 ..... 201  
 FN039 ..... 201  
 FN051 ..... 201  
 FN063 ..... 201  
 FN090 ..... 159  
 FN091 ..... 159  
 FN092 ..... 159  
 FN093 ..... 159  
 FN097 ..... 198  
 FN159 ..... 49  
 FN160 ..... 49  
 FN161 ..... 49  
 FN162 ..... 49  
 FN166 ..... 49  
 FN282 ..... 191, 364  
 FN283 ..... 191, 364  
 FN284 ..... 191, 364  
 FN345 ..... 321  
 FN348 ..... 325  
 FN350 ..... 327  
 FN351 ..... 323  
 FN352 ..... 323  
 FN353 ..... 323  
 FN354 ..... 323  
 FN355 ..... 323  
 FN356 ..... 323  
 FN357 ..... 335  
 FN361 ..... 336  
 FN362 ..... 337  
 FN363 ..... 337  
 FN364 ..... 337  
 FN365 ..... 337  
 FN366 ..... 337  
 FN367 ..... 337  
 FN368 ..... 336  
 FN369 ..... 335  
 FN370 ..... 335  
 FN371 ..... 331  
 FN372 ..... 332  
 FN373 ..... 339  
 FN417 ..... 349  
 FN418 ..... 349  
 FN419 ..... 349  
 FN420 ..... 349  
 FN421 ..... 343  
 FN422 ..... 343

FN423 ..... 343  
 FN424 ..... 343  
 FN425 ..... 343  
 FN426 ..... 343  
 FN427 ..... 343  
 FN428 ..... 343  
 FN429 ..... 347  
 FN430 ..... 347  
 FN431 ..... 345  
 FN432 ..... 345  
 FN433 ..... 345  
 FN434 ..... 347  
 FN435 ..... 347  
 FN436 ..... 347  
 FN437 ..... 345  
 FN438 ..... 345  
 FN441 ..... 339  
 FN442 ..... 339  
 FN443 ..... 339  
 FN444 ..... 339  
 FN445 ..... 339  
 FN446 ..... 339  
 FN447 ..... 339  
 FN448 ..... 339  
 FN454 ..... 190  
 FN455 ..... 190  
 FN457 ..... 171  
 FN458 ..... 171  
 FN459 ..... 171  
 FN460 ..... 171  
 FN461 ..... 171  
 FN462 ..... 171  
 FN463 ..... 171  
 FN464 ..... 171  
 FN465 ..... 171  
 FN466 ..... 171  
 FN467 ..... 171  
 FN468 ..... 171  
 FN469 ..... 181  
 FN470 ..... 181  
 FN471 ..... 181  
 FN472 ..... 181  
 FN473 ..... 181  
 FN474 ..... 181  
 FN475 ..... 181  
 FN476 ..... 181  
 FN477 ..... 181  
 FN478 ..... 181  
 FN479 ..... 181  
 FN480 ..... 181  
 FN481 ..... 181  
 FN482 ..... 181  
 FN483 ..... 181  
 FN484 ..... 181  
 FN485 ..... 181

FN486 ..... 181  
 FN487 ..... 181  
 FN488 ..... 181  
 FN489 ..... 181  
 FN490 ..... 181  
 FN491 ..... 181  
 FN492 ..... 181  
 FN493 ..... 165  
 FN494 ..... 165  
 FN495 ..... 165  
 FN496 ..... 165  
 FN497 ..... 165  
 FN498 ..... 165  
 FN499 ..... 165  
 FN500 ..... 165  
 FN501 ..... 165  
 FN502 ..... 165  
 FN503 ..... 165  
 FN504 ..... 165  
 FN505 ..... 165  
 FN506 ..... 165  
 FN507 ..... 165  
 FN508 ..... 165  
 FN509 ..... 203  
 FN510 ..... 203  
 FN511 ..... 203  
 FN512 ..... 203  
 FN513 ..... 203  
 FN514 ..... 203  
 FN516 ..... 203  
 FN517 ..... 165  
 FN518 ..... 165  
 FN519 ..... 165  
 FN520 ..... 165  
 FN521 ..... 165  
 FN522 ..... 165  
 FN523 ..... 165  
 FN524 ..... 165  
 FN525 ..... 165  
 FN526 ..... 165  
 FN527 ..... 165  
 FN528 ..... 165  
 FN529 ..... 165  
 FN530 ..... 165  
 FN531 ..... 165  
 FN532 ..... 165  
 FN549 ..... 171  
 FN550 ..... 171  
 FN551 ..... 171  
 FN552 ..... 171  
 FN553 ..... 171  
 FN555 ..... 171  
 FN556 ..... 171  
 FN557 ..... 171  
 FN559 ..... 171

FN560 ..... 171  
 FN561 ..... 171  
 FN562 ..... 171  
 FN681 ..... 262  
 FN685 ..... 262  
 FN686 ..... 262  
 FN687 ..... 262  
 FN688 ..... 262  
 FN689 ..... 262  
 FN690 ..... 262  
 FN692 ..... 262  
 FN694 ..... 262  
 FN695 ..... 262  
 FN727 ..... 295  
 FN808 ..... 198  
 FN809 ..... 198  
 FN827 ..... 176  
 FN828 ..... 176  
 FN876 ..... 185  
 FN877 ..... 185  
 FN878 ..... 185  
 FN879 ..... 185  
 FN880 ..... 185  
 FN881 ..... 185  
 FN882 ..... 185  
 FN883 ..... 185  
 FN884 ..... 185  
 FN885 ..... 185  
 FN897 ..... 185  
 FN898 ..... 185  
 FN899 ..... 185  
 FN922 ..... 185  
 FN923 ..... 185  
 FN924 ..... 185  
 FN928 ..... 175  
 FN929 ..... 175  
 FN930 ..... 175  
 FN931 ..... 175  
 FN932 ..... 175  
 FN935 ..... 175  
 FN940 ..... 176  
 FN941 ..... 176  
 FN942 ..... 176  
 FN943 ..... 177  
 FN946 ..... 177  
 FN949 ..... 343  
 FN950 ..... 343  
 FN951 ..... 343  
 FN952 ..... 343  
 FN976 ..... 349, 370  
 FN977 ..... 349, 370  
 FN978 ..... 349, 370  
 FN995 ..... 259  
 FN996 ..... 259  
 FN997 ..... 259

FN998 ..... 259  
 FP001 ..... 259  
 FP012 ..... 311  
 FP016 ..... 311  
 FP017 ..... 311  
 FP018 ..... 311  
 FP019 ..... 311  
 FP020 ..... 311  
 FP021 ..... 309  
 FP022 ..... 309  
 FP023 ..... 309  
 FP024 ..... 309  
 FP025 ..... 309  
 FP026 ..... 309  
 FP027 ..... 309  
 FP028 ..... 309  
 FP029 ..... 316  
 FP030 ..... 316  
 FP031 ..... 316  
 FP038 ..... 307  
 FP039 ..... 307  
 FP041 ..... 307  
 FP042 ..... 307  
 FP043 ..... 307  
 FP044 ..... 307  
 FP045 ..... 307  
 FP046 ..... 307  
 FP047 ..... 307  
 FP048 ..... 307  
 FP049 ..... 307  
 FP050 ..... 315  
 FP051 ..... 315  
 FP052 ..... 315  
 FP053 ..... 315  
 FP054 ..... 314  
 FP055 ..... 314  
 FP056 ..... 314  
 FP057 ..... 313  
 FP058 ..... 310  
 FP059 ..... 316  
 FP060 ..... 310  
 FP061 ..... 310  
 FP062 ..... 314  
 FP063 ..... 310  
 FP064 ..... 312  
 FP065 ..... 312  
 FP066 ..... 312  
 FP067 ..... 314  
 FP068 ..... 314  
 FP085 ..... 175  
 FP086 ..... 175  
 FP087 ..... 175  
 FP088 ..... 175  
 FP089 ..... 175  
 FP090 ..... 175

FP091 ..... 177  
 FP092 ..... 177  
 FP111 ..... 176  
 FP112 ..... 176  
 FP117 ..... 265  
 FP119 ..... 265  
 FP120 ..... 265  
 FP121 ..... 265  
 FP122 ..... 265  
 FP124 ..... 265  
 FP130 ..... 195  
 FP131 ..... 195  
 FP132 ..... 195  
 FP133 ..... 195  
 FP134 ..... 195  
 FP135 ..... 195  
 FP167 ..... 295  
 FP168 ..... 295  
 FP171 ..... 169  
 FP172 ..... 169  
 FP173 ..... 169  
 FP174 ..... 169  
 FP175 ..... 169  
 FP176 ..... 169  
 FP177 ..... 169  
 FP178 ..... 169  
 FP179 ..... 183  
 FP180 ..... 183  
 FP181 ..... 183  
 FP182 ..... 179, 183  
 FP183 ..... 183  
 FP184 ..... 183  
 FP185 ..... 183  
 FP186 ..... 183  
 FP187 ..... 183  
 FP188 ..... 151  
 FP189 ..... 183  
 FP190 ..... 151  
 FP191 ..... 183  
 FP192 ..... 167  
 FP193 ..... 152  
 FP194 ..... 167  
 FP195 ..... 153  
 FP196 ..... 152  
 FP197 ..... 152  
 FP198 ..... 150  
 FP199 ..... 167  
 FP200 ..... 167  
 FP201 ..... 167  
 FP202 ..... 167  
 FP203 ..... 167  
 FP228 ..... 295  
 FP235 ..... 235  
 FP236 ..... 235  
 FP237 ..... 235

FP238 ..... 235  
 FP239 ..... 235  
 FP240 ..... 235  
 FP241 ..... 235  
 FP242 ..... 235  
 FP243 ..... 235  
 FP244 ..... 235  
 FP245 ..... 235  
 FP246 ..... 235  
 FP247 ..... 235  
 FP248 ..... 235  
 FP249 ..... 235  
 FP250 ..... 235  
 FP251 ..... 235  
 FP252 ..... 235  
 FP253 ..... 235  
 FP254 ..... 235  
 FP255 ..... 235  
 FP256 ..... 235  
 FP257 ..... 235  
 FP258 ..... 235  
 FP259 ..... 235  
 FP260 ..... 235  
 FP261 ..... 235  
 FP262 ..... 235  
 FP263 ..... 235  
 FP264 ..... 235  
 FP265 ..... 235  
 FP266 ..... 235  
 FP267 ..... 235  
 FP268 ..... 235  
 FP269 ..... 235  
 FP270 ..... 235  
 FP271 ..... 235  
 FP272 ..... 235  
 FP273 ..... 235  
 FP274 ..... 316  
 FP275 ..... 316  
 FP277 ..... 287  
 FP278 ..... 287  
 FP279 ..... 287  
 FP280 ..... 287  
 FP281 ..... 287  
 FP286 ..... 235  
 FP287 ..... 235  
 FP288 ..... 235  
 FP303 ..... 19  
 FP305 ..... 207  
 FP306 ..... 207  
 FP307 ..... 207  
 FP308 ..... 207  
 FP309 ..... 207  
 FP310 ..... 207  
 FP311 ..... 207  
 FP312 ..... 207

FP313 ..... 207  
 FP314 ..... 207  
 FP315 ..... 239  
 FP316 ..... 239  
 FP317 ..... 239  
 FP318 ..... 239  
 FP320 ..... 95, 131, 143  
 FP321 ..... 95, 131  
 FP322 ..... 283  
 FP323 ..... 283  
 FP324 ..... 283  
 FP325 ..... 283  
 FP326 ..... 283  
 FP331 ..... 145  
 FP332 ..... 95, 151  
 FP349 ..... 355  
 FP350 ..... 355  
 FP351 ..... 355  
 FP357 ..... 50  
 FP359 ..... 209  
 FP361 ..... 221  
 FP362 ..... 221  
 FP363 ..... 221  
 FP364 ..... 221  
 FP365 ..... 221  
 FP366 ..... 221  
 FP367 ..... 221  
 FP368 ..... 221  
 FP369 ..... 221  
 FP370 ..... 221  
 FP373 ..... 19  
 FP374 ..... 19  
 FP375 ..... 19  
 FP381 ..... 313  
 FP382 ..... 313  
 FP383 ..... 313  
 FP384 ..... 231  
 FP385 ..... 231  
 FP386 ..... 231  
 FP387 ..... 231  
 FP388 ..... 231  
 FP393 ..... 231  
 FP394 ..... 231  
 FP395 ..... 231  
 FP398 ..... 231  
 FP399 ..... 231  
 FP400 ..... 231  
 FP401 ..... 231  
 FP402 ..... 231  
 FP403 ..... 231  
 FP408 ..... 231  
 FP409 ..... 231  
 FP410 ..... 231  
 FP413 ..... 231  
 FP414 ..... 231

FP415 ..... 231  
 FP416 ..... 231  
 FP417 ..... 231  
 FP418 ..... 231  
 FP423 ..... 231  
 FP424 ..... 231  
 FP425 ..... 231  
 FP428 ..... 231  
 FP430 ..... 357  
 FP431 ..... 356  
 FP432 ..... 356  
 FP433 ..... 356  
 FP439 ..... 187  
 FP440 ..... 187  
 FP444 ..... 187  
 FP445 ..... 187  
 FP446 ..... 187  
 FP447 ..... 187  
 FP448 ..... 187  
 FP449 ..... 187  
 FP450 ..... 187  
 FP452 ..... 187  
 FP453 ..... 187  
 FP458 ..... 187  
 FP459 ..... 187  
 FP460 ..... 356  
 FP461 ..... 356  
 FP462 ..... 357  
 FP463 ..... 357  
 FP464 ..... 237  
 FP465 ..... 237  
 FP466 ..... 237  
 FP467 ..... 237  
 FP468 ..... 237  
 FP469 ..... 237  
 FP470 ..... 237  
 FP471 ..... 358  
 FP472 ..... 358  
 FP473 ..... 360  
 FP474 ..... 278  
 FP475 ..... 278  
 FP476 ..... 360  
 FP477 ..... 278  
 FP478 ..... 278  
 FP479 ..... 278  
 FP480 ..... 278  
 FP481 ..... 278  
 FP482 ..... 278  
 FP483 ..... 278  
 FP484 ..... 278  
 FP486 ..... 278  
 FP487 ..... 280  
 FP488 ..... 280  
 FP489 ..... 280  
 FP490 ..... 280

FP491	..... 280
FP493	..... 280
FP494	..... 277
FP495	..... 277
FP496	..... 317
FP497	..... 317
FP498	..... 317
FP499	..... 277
FP500	..... 317
FP501	..... 277
FP502	..... 277
FP503	..... 317
FP504	..... 277
FP505	..... 317
FP506	..... 281
FP507	..... 281
FP508	..... 281
FP509	..... 281
FP510	..... 281
FP512	..... 358
FP513	..... 358
FP514	..... 358
FP515	..... 359
FP516	..... 281
FP518	..... 359
FP519	..... 281
FP520	..... 359
FP521	..... 360
FP522	..... 359
FP523	..... 280
FP524	..... 280
FP525	..... 359
FP526	..... 280
FP527	..... 359
FP528	..... 280
FP529	..... 280
FP530	..... 359
FP531	..... 280
FP532	..... 280
FP533	..... 280
FP534	..... 280
FP535	..... 277
FP536	..... 277
FP537	..... 277
FP538	..... 277
FP539	..... 277
FP540	..... 277
FP541	..... 277
FP542	..... 277
FP543	..... 280
FP544	..... 280
FP545	..... 280
FP546	..... 280
FP547	..... 280
FP548	..... 280

FP549	..... 280
FP550	..... 280
FP551	..... 281
FP552	..... 281
FP553	..... 281
FP554	..... 281
FP555	..... 281
FP557	..... 281
FP558	..... 279
FP559	..... 279
FP560	..... 279
FP561	..... 279
FP562	..... 279
FP564	..... 279
FP565	..... 279
FP566	..... 279
FP567	..... 279
FP568	..... 279
FP569	..... 279
FP570	..... 279
FP571	..... 296
FP572	..... 296
FP573	..... 296
FP574	..... 296
FP575	..... 296
FP576	..... 281
FP614	..... 179
FP615	..... 179
FP616	..... 179
FP617	..... 179
FP618	..... 179
FP619	..... 209
FP620	..... 208
FP631	..... 17
FP632	..... 17
FP633	..... 17, 116
FP642	..... 278
FP643	..... 278
FP644	..... 278
FP645	..... 278
FP646	..... 278
FP647	..... 278
FP648	..... 278
FP649	..... 280
FP650	..... 280
FP651	..... 280
FP652	..... 277
FP653	..... 277
FP654	..... 281
FP655	..... 281
FP656	..... 281
FP657	..... 281
FP664	..... 277
FP665	..... 277
FP666	..... 279

FP667	..... 279
FP668	..... 279
FP669	..... 280
FP670	..... 280
FP671	..... 280
FP672	..... 281
FP673	..... 281
FP675	..... 177
FP678	..... 17
FP683	..... 97
FP684	..... 97
FP685	..... 179
FP686	..... 179
FP693	..... 313
FP694	..... 313
FP699	..... 358
FP700	..... 360
FP701	..... 278
FP702	..... 278
FP703	..... 278
FP704	..... 278
FP705	..... 278
FP706	..... 278
FP723	..... 312
FP724	..... 274
FP725	..... 274
FP727	..... 274
FP728	..... 274
FP729	..... 274
FP730	..... 274
FP731	..... 274
FP732	..... 275
FP733	..... 275
FP734	..... 275
FP735	..... 275
FP736	..... 275
FP737	..... 275
FP738	..... 275
FP739	..... 275
FP740	..... 144
G0036	..... 53
G2562	..... 107
G2639	..... 129
G2712	..... 255
G3322	..... 53, 364
G3323	..... 53, 364
G3367	..... 50, 130
G3368	..... 50, 364
G3570	..... 26, 136
G3573	..... 26, 136
G3611	..... 108
G3658	..... 27, 364
G3659	..... 27, 130
G3666	..... 27, 130
G3674	..... 27

G3745	..... 226
G3751	..... 226
G3752	..... 226
G3753	..... 226
G3754	..... 226
G3765	..... 226
G3960	..... 138
H0736	..... 81
H2090	..... 59,
	119
H2317	..... 59
H2318	..... 59
H3008	..... 85
H3032	..... 85
H3089	..... 85,
	138
H3607	..... 243
H3608	..... 243
H3609	..... 243
H3610	..... 243
H3611	..... 243
H3612	..... 243
H3615	..... 243
H3856	..... 85,
	138
H3858	..... 85
H4870	..... 106
H5057	..... 129
H5169	..... 85
H8466	..... 58,
	118
H9211	..... 141
HB001	..... 177
HB002	..... 177
HB102	..... 176
HB165	..... 175
HB182	..... 175
HB217	..... 175
HB248	..... 175
HB253	..... 175
HB255	..... 175
HB260	..... 175
HB281	..... 175
HB288	..... 175
HB298	..... 177
HB324	..... 175
HB355	..... 177
HB634	..... 176
HB778	..... 176
HB867	..... 176
HBL00	..... 177
HBL01	..... 177
HBL11	..... 175
HBL16	..... 175
HBL18	..... 175



HBL21	175	HL182	175	J8908	39, 117	MB220	269
HBL24	175	HL217	175	J9014	39	MB246	270
HBL25	175	HL248	175	L0371	71, 119, 123	MB247	270
HBL26	175	HL253	175	L0571	24, 362	MB248	270
HBL28	175	HL255	175	L2356	50	MB249	270
HBL29	177	HL260	175	L2369	27	MB250	270
HBL35	177	HL281	175	L2370	27, 130	MB251	270
HBL38	175	HL288	175	L2609	45	MB252	270
HG001	177	HL298	177	L2761	45	MB253	270
HG002	177	HL355	177	L2762	45, 117	MB254	270
HG102	175	HN001	177	L2804	244	MB296	272, 274
HG112	175	HN002	177	L2805	244	MB297	272, 274
HG165	175	HN113	175	L2808	244	MB298	272
HG182	175	HN165	175	L2810	244	MB299	272
HG217	175	HN182	175	L2811	244	MB300	272, 274
HG248	175	HN217	175	L3678	45, 116, 122	MB301	272, 274
HG253	175	HN248	175	L3963	146, 364	MB302	272
HG255	175	HN253	175	L3965	146	MB303	272
HG260	175	HN255	175	L4193	147	MB304	300
HG281	175	HN260	175	L4194	147	MB305	300
HG288	175	HN281	175	L4212	146	MB306	300
HG298	177	HN288	175	L4257	147	MB307	300
HG324	175	HN298	177	L4865	103, 138	MB308	300
HG355	177	HN317	175	L5216	85	MB309	300
HG650	175	HN355	177	L5217	85	MB311	272
HG725	175	HND63	176	L5633	41	MB312	272
HG867	175	HND77	176	L5635	41	MB316	300
HG975	175	HNW10	176	L5636	41	MB317	300
HG978	175	HNW86	176	L5636*	364	MB318	300
HGC11	177	HS001	152	L5637	41, 364	MB319	300
HGC13	177	HS002	152	L5638	41	MB320	300
HGD10	175	J0226	254	L5640	42, 117	MB321	272, 274
HGD11	175	J0232	254	L5641	42, 116, 122	MB322	272
HGR11	177	J0825	139	L5642	43	MB323	272
HGR13	177	J0856	254	L5754	43	MB324	272
HI102	175	J1478	58, 118	L5755	43	MB326	272
HI111	175	J2605	79	L5756	43, 130	MB327	272
HI113	177	J2610	79	L5757	43, 130	MB329	272
HI145	177	J2611	79	L5758	43, 130	MB331	272
HI156	177	J3811	361	L6119	133, 142	MB337	272
HI227	177	J4089	138	L6247	146	MB341	272
HI650	175	J4094	78, 364	L6689	255	MT002	153
HI725	175	J4096	78	L6850	249	MT004	152
HI867	175	J4097	78	L7254	95, 131, 143	MT011	152
HI975	175	J4099	78	L7255	95	MT051	150
HI978	175	J4101	78	L7256	95	MT849	151
HIC11	177	J4102	78	L7844	79	MT850	151
HIC13	177	J4103	78	L8110	50	N0512	91
HID10	175	J4104	78	L8677	53	N0513	91
HID11	175	J4106	138	L8970	138	N0520	91
HIR11	177	J4238	105	M0090	254	N0521	91
HIR13	177	J8742	39	MB201	269	N0523	91
HL001	177	J8743	39	MB202	269	N0524	91, 131
HL002	177	J8821	138	MB203	269	N0527	91
HL165	175	J8907	39, 117	MB204	269	N0528	91

N0529 ..... 91, 129  
 N0530 ..... 91  
 N0531 ..... 91, 131  
 N0834 ..... 51, 364  
 N1738 ..... 39  
 N1739 ..... 45  
 N2608 ..... 254  
 N2644 ..... 140  
 N2760 ..... 126  
 N3295 ..... 251  
 N3567 ..... 251  
 N4742 ..... 45  
 N4907 ..... 63  
 N5082 ..... 62, 119  
 N5163 ..... 63  
 N5368 ..... 45, 136  
 N5812 ..... 107  
 N5828 ..... 107  
 N5834 ..... 129  
 N5993 ..... 63  
 N5994 ..... 63  
 N5995 ..... 63, 131  
 N6216 ..... 125  
 N6374 ..... 132  
 N6393 ..... 248  
 N6643 ..... 105  
 N6815 ..... 26, 122  
 N6831 ..... 26, 124  
 N7945 ..... 254  
 N8172 ..... 132  
 N8212 ..... 132  
 N8901 ..... 77  
 N9360 ..... 244  
 N9361 ..... 244  
 N9362 ..... 244  
 N9364 ..... 244  
 N9365 ..... 245  
 N9395 ..... 245  
 N9397 ..... 245  
 N9411 ..... 244  
 N9696 ..... 40  
 N9710 ..... 41  
 N9711 ..... 43, 136  
 ODP36 ..... 158  
 OL166 ..... 153  
 OL167 ..... 150  
 P0089 ..... 43, 136  
 P0112 ..... 25  
 P0310 ..... 251  
 P0447 ..... 244  
 P0776 ..... 71  
 P0777 ..... 71  
 P0887 ..... 251  
 P1122 ..... 245  
 P1139 ..... 245

P1470 ..... 95  
 P3008 ..... 139  
 P3882 ..... 26, 124  
 P3946 ..... 243  
 P3967 ..... 249  
 P3972 ..... 248  
 P4025 ..... 251  
 P4188 ..... 101, 131  
 P6284 ..... 106, 364  
 P8332 ..... 251  
 P8494 ..... 65  
 P8495 ..... 65, 131  
 P8496 ..... 131  
 P8499 ..... 65  
 P8500 ..... 65, 131  
 P8782 ..... 61, 137  
 P8790 ..... 61  
 P8793 ..... 60, 119  
 P8794 ..... 61  
 P8795 ..... 95, 125  
 P8796 ..... 95, 123  
 P8821 ..... 95, 126  
 P9067 ..... 101, 131  
 P9771 ..... 244  
 P9772 ..... 244  
 P9773 ..... 244  
 Q1069 ..... 40, 362  
 Q1151 ..... 35, 49, 117  
 Q1325 ..... 99, 125  
 Q1774 ..... 77  
 Q2233 ..... 75  
 Q2234 ..... 75  
 Q2504 ..... 111  
 Q2505 ..... 111  
 Q2517 ..... 111  
 Q2518 ..... 111  
 Q2536 ..... 111  
 Q2537 ..... 111  
 Q2538 ..... 111  
 Q2539 ..... 111  
 Q2540 ..... 111  
 Q2542 ..... 111  
 Q2750 ..... 75  
 Q2751 ..... 75  
 Q2967 ..... 75  
 Q3700 ..... 75  
 Q3701 ..... 75  
 Q3702 ..... 42, 122  
 Q4025 ..... 146  
 Q4026 ..... 146  
 Q4033 ..... 146  
 Q4340 ..... 54  
 Q4353 ..... 54, 130  
 Q4354 ..... 55, 130  
 Q4358 ..... 55

Q5761 ..... 105, 129  
 Q6480 ..... 77  
 Q7781 ..... 105  
 Q7785 ..... 42, 116, 122  
 Q7932 ..... 95, 125  
 Q8201 ..... 99  
 Q8701 ..... 99  
 Q8947 ..... 101  
 Q9062 ..... 29  
 Q9064 ..... 29  
 Q9080 ..... 29, 116  
 R0020 ..... 144  
 R0735 ..... 226  
 R0736 ..... 226  
 R0738 ..... 226  
 R0741 ..... 226, 364  
 R0801 ..... 208  
 R0802 ..... 208  
 R0803 ..... 208  
 R0804 ..... 208  
 R0805 ..... 208  
 R0806 ..... 208  
 R0807 ..... 209  
 R0809 ..... 209  
 R0811 ..... 208  
 R0817 ..... 209  
 R0819 ..... 209  
 R0830 ..... 209  
 R0833 ..... 209  
 R0835 ..... 209  
 R0839 ..... 209  
 R0840 ..... 209  
 R0850 ..... 208  
 R0851 ..... 208  
 R0852 ..... 208  
 R0882 ..... 209  
 R0901 ..... 222  
 R0902 ..... 222  
 R0903 ..... 222  
 R0904 ..... 222  
 R0905 ..... 222  
 R0906 ..... 222  
 R0907 ..... 222  
 R0908 ..... 223  
 R0917 ..... 223  
 R0918 ..... 223  
 R0919 ..... 223  
 R0926 ..... 223  
 R0928 ..... 223  
 R0929 ..... 223  
 R0931 ..... 223  
 R0932 ..... 223  
 R0933 ..... 223  
 R0947 ..... 223  
 R0950 ..... 223

R0959 ..... 223  
 R0960 ..... 223  
 R0968 ..... 223  
 RBB02 ..... 153  
 RBB06 ..... 153  
 RBBR7 ..... 153  
 RBDG3 ..... 153  
 RBP04 ..... 153  
 RBR09 ..... 153  
 RBW06 ..... 153  
 RBY03 ..... 153  
 S0602 ..... 217  
 S0603 ..... 217  
 S0604 ..... 217  
 S0606 ..... 217  
 S0628 ..... 217  
 S0630 ..... 217  
 S0633 ..... 217  
 S0638 ..... 217  
 S1501 ..... 219  
 S1502 ..... 219  
 S1503 ..... 219  
 S1504 ..... 219  
 S1506 ..... 219  
 S1507 ..... 219  
 S1508 ..... 219  
 S1509 ..... 219  
 S1512 ..... 219  
 S1517 ..... 219  
 S1518 ..... 219  
 S1521 ..... 219  
 S1528 ..... 219  
 S1530 ..... 219  
 S1533 ..... 219  
 S1534 ..... 219  
 S1535 ..... 219  
 S1538 ..... 219  
 S1550 ..... 219  
 S1916 ..... 217  
 SCP99 ..... 271  
 SCR98 ..... 271  
 SOL01 ..... 273  
 SOL02 ..... 273, 275  
 SOL04 ..... 273  
 SOL05 ..... 273, 275  
 SOL06 ..... 273, 275  
 SOL08 ..... 273  
 SOL10 ..... 273  
 SOL11 ..... 273  
 SOL13 ..... 273  
 SOL20 ..... 273  
 SOL28 ..... 273  
 SOM01 ..... 273  
 SOM02 ..... 273  
 SOM04 ..... 273

SOM05 ..... 273  
SOM06 ..... 273  
SOM10 ..... 273  
SOM28 ..... 273  
T0417 ..... 299  
T0418 ..... 264, 299  
T0421 ..... 299  
T0422 ..... 299  
T0426 ..... 264, 295  
T1801 ..... 291  
T1802 ..... 291  
T1804 ..... 291  
T1805 ..... 291  
T1806 ..... 291  
T1808 ..... 291  
T1809 ..... 291  
T1811 ..... 291  
T1813 ..... 301  
T1816 ..... 301  
T1817 ..... 301  
T1818 ..... 301  
T1819 ..... 301  
T1820 ..... 301  
T1821 ..... 301  
T1822 ..... 301  
T1824 ..... 301  
T1825 ..... 301  
T1826 ..... 297  
T1828 ..... 291  
T1829 ..... 291  
T1901 ..... 287  
T1902 ..... 287  
T1904 ..... 287  
T1906 ..... 287  
T1911 ..... 287  
T1928 ..... 287  
T1929 ..... 287  
T3601 ..... 285  
T3602 ..... 285  
T3604 ..... 285  
T3606 ..... 285  
T3611 ..... 285  
T3621 ..... 285  
T3627 ..... 285  
T3628 ..... 285  
T3629 ..... 285  
T4701 ..... 264  
T4702 ..... 264  
T4704 ..... 264  
T4706 ..... 264  
T4709 ..... 264  
T4711 ..... 264  
T4727 ..... 264, 299  
T4728 ..... 264  
T4729 ..... 264

T4801 ..... 265  
T4802 ..... 265  
T4804 ..... 265  
T4806 ..... 265  
T4809 ..... 265  
T4811 ..... 265  
T4828 ..... 265  
T4829 ..... 265  
T4901 ..... 266  
T4902 ..... 266  
T4904 ..... 266  
T4905 ..... 266  
T4906 ..... 266  
T4908 ..... 266  
T4909 ..... 266  
T4911 ..... 266  
T4918 ..... 266  
T4927 ..... 266  
T4928 ..... 266  
T4929 ..... 266  
T5101 ..... 260  
T5102 ..... 260  
T5104 ..... 260  
T5105 ..... 260  
T5106 ..... 260  
T5109 ..... 260  
T5111 ..... 260  
T5121 ..... 260  
T5127 ..... 260  
T5128 ..... 260  
T5129 ..... 260  
T5201 ..... 261  
T5202 ..... 261  
T5204 ..... 261  
T5206 ..... 261  
T5209 ..... 261  
T5211 ..... 261  
T5221 ..... 261  
T5227 ..... 261  
T5228 ..... 261  
T5229 ..... 261  
T5401 ..... 263  
T5402 ..... 263  
T5404 ..... 263  
T5405 ..... 263  
T5406 ..... 263  
T5408 ..... 263  
T5409 ..... 263  
T5410 ..... 263  
T5411 ..... 263  
T5427 ..... 263  
T5428 ..... 263  
T5429 ..... 263  
T7801 ..... 288  
T7802 ..... 288

T7804 ..... 288  
T7806 ..... 288  
T7828 ..... 288  
T7829 ..... 288  
T8001 ..... 289  
T8002 ..... 289  
T8004 ..... 289  
T8006 ..... 289  
T8008 ..... 289  
T8009 ..... 289  
T8011 ..... 289  
T8018 ..... 289  
T8028 ..... 289  
T8029 ..... 289  
U1010 ..... 37  
U1011 ..... 37  
U1012 ..... 37  
U1013 ..... 37  
U1032 ..... 37, 132, 364  
U1033 ..... 37  
U1051 ..... 36, 117  
V0391 ..... 47  
V0410 ..... 144  
V1171 ..... 47, 122  
V1483 ..... 47  
V1536 ..... 247  
V1537 ..... 247  
V1538 ..... 247  
V1539 ..... 247  
V1540 ..... 247  
V1653 ..... 247  
V2125 ..... 61  
V2128 ..... 60, 362  
V2159 ..... 245  
V2620 ..... 31  
V2696 ..... 47  
V2697 ..... 47, 116  
V2760 ..... 61, 125  
V2761 ..... 61, 123  
V2821 ..... 31  
V2822 ..... 31  
V2823 ..... 31, 117  
V2910 ..... 95, 129  
V3469 ..... 105, 131  
V3470 ..... 77  
V3471 ..... 139  
V3472 ..... 105  
V3473 ..... 77  
V3475 ..... 105  
V3476 ..... 105, 131  
V3604 ..... 45  
V3870 ..... 107  
V3871 ..... 77  
V3872 ..... 137  
V3873 ..... 137

V3874 ..... 119, 123  
V4024 ..... 61  
V4025 ..... 61, 125  
V4222 ..... 61, 127  
V5794 ..... 26, 132  
V5926 ..... 108  
V5927 ..... 108, 364  
V5996 ..... 95  
V5998 ..... 95  
V6189 ..... 35  
V6190 ..... 35  
V6191 ..... 35  
V7429 ..... 255  
V7445 ..... 139  
V7462 ..... 80  
V7483 ..... 80  
V7529 ..... 80  
V7636 ..... 82, 83  
V7637 ..... 82, 83  
V7655 ..... 255  
V8704 ..... 82, 83  
V8705 ..... 82, 83  
V8710 ..... 82, 83  
V8711 ..... 82, 83  
V8924 ..... 79  
V8953 ..... 143  
V8954 ..... 143  
V8956 ..... 143



Plating/Beverage Artists

**MidiCi @midici, Los Angeles, CA**

Arcoroc® Pilsners, *featured on page 132*

**Chef Dennis MacDonald, @dennis.eats**

Chef & Sommelier® Eternity Plus, *featured on page 186*

**Miami Chef Studios, Miami, FL**

Chasseur, *featured on page 332*

**Valeria Pinto @VibrantValeria, RezDóra, New York, NY**

Arcoroc® Candour Azure, *featured on page 200*

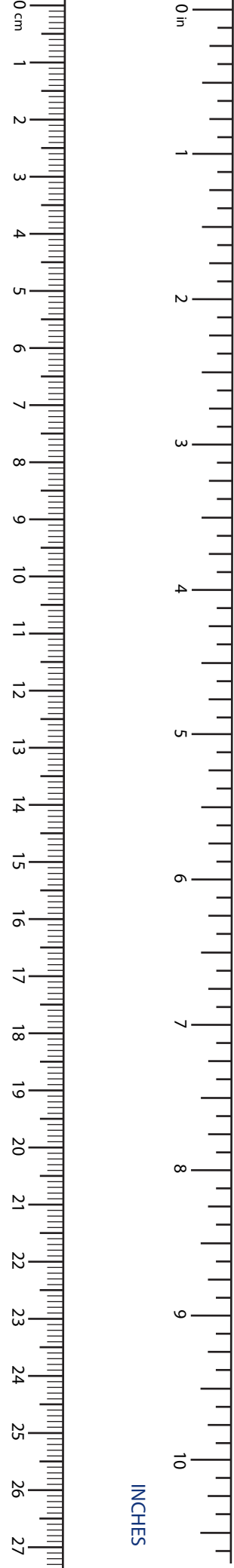

CENTIMETERS

INCHES



**arc**  
cardinal

**2024/2025 PORTFOLIO**

**ARCCARDINAL.COM**

45A Commerce Way Totowa, NJ 07512  
973-628-0900 | CardinalSales@arc-intl.com