

SERVOLIFT

Experts in Process, Handling & Design

Ergonomic Mobile Drum Lifter

The stress reliever for drum handling operations

SERVOLIFT has manufactured over 1300 of these machines to-date. The strange looking unit is the result of full optimization for drum handling. When handling a 250Kg load, the unit requires only ~13-lbs for pushing force to reverse the rear swivel wheels and ~8-Lbs thereafter to move it around. Grab, Lift, & Tip (anywhere between 0-180°). Ideal for manual scooping powders from drums or anywhere you need to move heavy drums.



Combine with our Drums, Funnels and Drum Nests for a complete handling system

SERVOLIFT
Experts in Process, Handling & Design

SERVOLIFT
105-B West Dewey Ave
Wharton, NJ 07885
Ph: 973-442-7878 - www.servo-lift.com

The Advantage: Proven Designs - Fully Customized - Unmatched Experience

Profile

Available in manually pushed and self propelled versions. With battery, pneumatic or plug-in electric power.

Designed for all drum types: fiber, plastic and steel.

Powered functions: Grab, Lift, Invert (180 deg) & Drive.

Meets or exceeds FDA and USDA requirements.

Offered in all grades of stainless steel or painted carbon steel.

Explosion proof option for all classified areas

System Features

All Models power grab, lift and freely invert drums between 0-180°

The Model SLN is a miniature unit of the SL 150 & SL 250 units

Model SLD 250 has a rotatable base for operations in tight areas (can work like a stationary unit).

The model SLF has a powered self propulsion system.

The 150 designates 330 lbs capacity and the 250 550 lbs. Optionally we can offer 660 lbs capacity.

Power

- Your choice: Battery, Air or Plug-in Electrical. General Purpose or Class 1/2, Division 1/2 Explosion Proof

Materials of Construction

- 304 Stainless Steel - welds continuous and ground smooth. Entire unit polished to a #4 luster, polish grain in uniform directions for a professional look.
- Non-Marking wheels with stainless housings. Wheels in white Plastic.

Other Advantages

- Most GMP drum lifter on the market
- Most proven design - manufactured since 1977 - the design is perfected

Model: SL-250/SLN-150

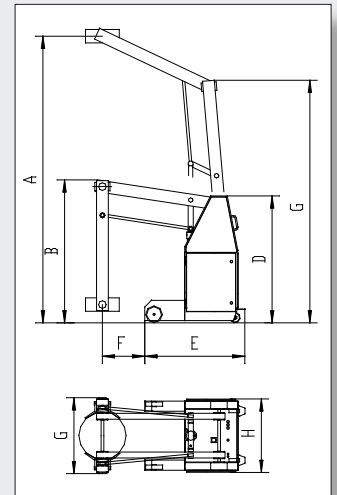

Model: SLF-250

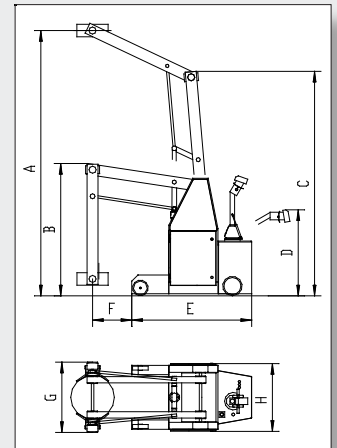

Model: SLD-250

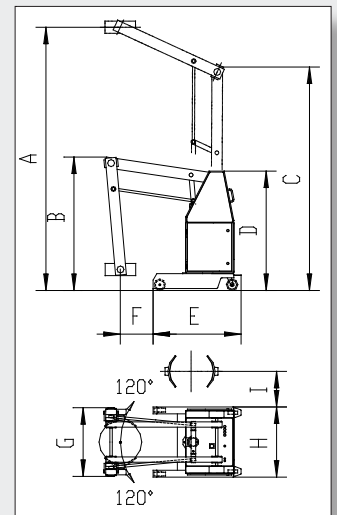

Model	A	B	C	D	E	F	G	H	I
SL-250	133.9"	66.8"	113.3"	59.3"	46.8"	18.5"	35.4"	34.3"	-
SLD-250	135.8"	68.7"	115.3"	61.6"	45.4"	16.9"	35.4"	36.2"	18.4"
SLF-250	133.8"	66.8"	113.3"	60.5"	60.5"	19.8"	35.4"	34.2"	-
SLN-150	79.9"	58.7"	77.2"	48.3"	46.8"	20.1"	35.4"	32.6"	-